

➤ A4™ 刀具及 Beyond™ 刀片

用于各种外圆和内圆加工。应用类型

主要应用

选择 A4 刀具系统，可用于多种工件材料的车削、端面、切槽、端面切槽，以及切断加工。独特的夹持装置以及多种刀片槽型，具有业内最高的金属切除率。

特点及优势

A4切槽及车削刀具

- 一款可用于车削、端面加工、切槽、端面切槽、切断，外圆、以及内圆加工的刀具产品 - 可以大幅缩短加工周期，转塔不会出现转位现象。
- 超长的夹持区域，底部120度的棱形支持面，以及具有专利权的顶部导轨设计，使产品在进行切槽和横向车削时具有无以比拟的稳定性。
- 精确的刀片定位性能 - 可用于精确切削加工。
- 即使在加工条件最为苛刻的切削加工中，具有良好刚性的夹具系统仍然可以稳固地锁定刀片。
- 多功能的设计方案，单个刀具系统既可进行外圆、内圆、切槽、端面切槽、背车、根切加工，甚至还可进行螺纹加工。
- 具有切屑控制性能的刀片可在切槽加工中顺利排出切屑，并且在多向车削加工中具有更好的切屑控制性能。

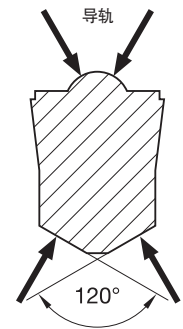

A4 断屑器

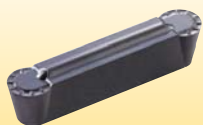

GMN 断屑器



GMP 断屑器



GMN 断屑器



GMP 断屑器

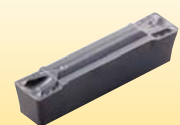

GUP 断屑器



A4™ 刀具系统可提高加工效率

- 可用于多种加工应用。
- 降低刀具成本。
- 缩短加工时间。



■ 步骤一 • 选择切槽及车削加工用的A4刀片规格

您需要了解的:

- 切槽深度、宽度，及形状。
- 加工材料。
- 可用于外圆及内圆切槽、车削、端面切槽，以及切断加工。

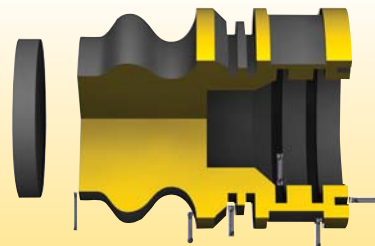

选择刀片规格的一般建议

工件直径	刀片 安装座尺寸
<25mm	3
25-50mm	4
>50mm	5-10

■ 步骤二 • 选择断屑槽类型和进给率

根据应用类型和安装座尺寸，
确定推荐的槽型及初始进给率。

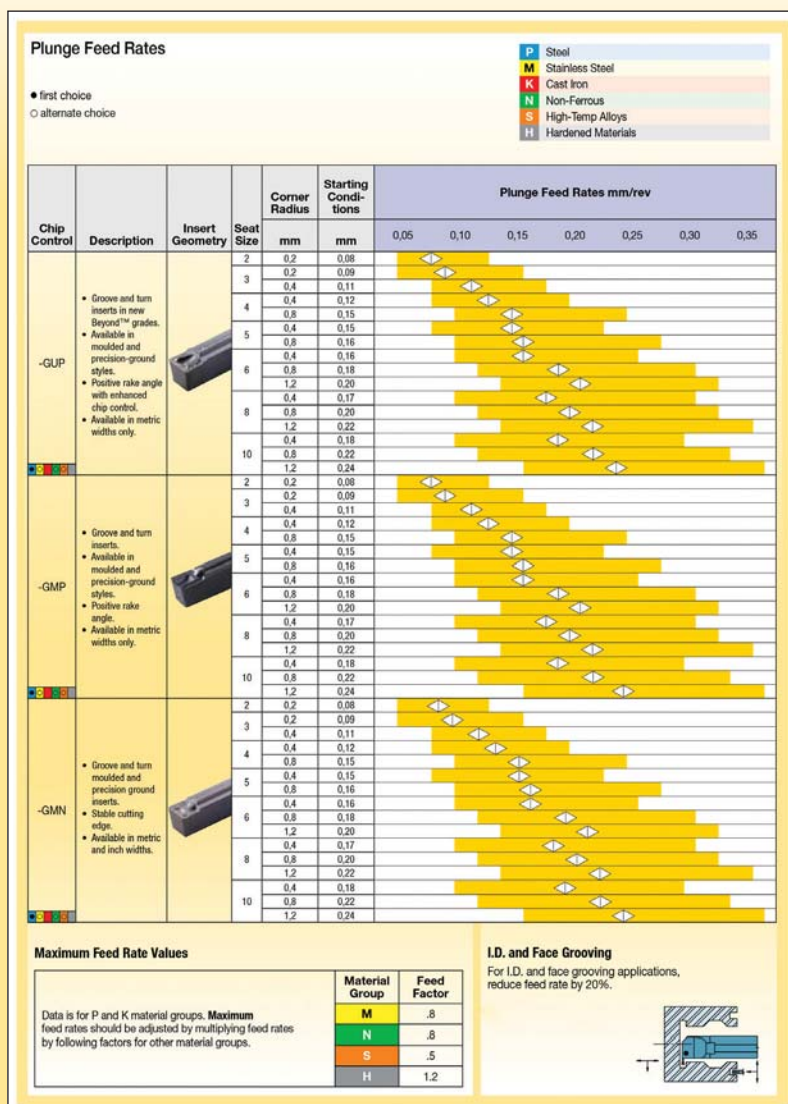

■ 步骤三 • 选择初始切削速度

根据材料分组和材质情况，
确定初始速度 (vc)。
首选方案显示为粗体。

- A 根据材料组和材质情况，
确定初始切削速度 (vc)。
- B 首选初始切削速度显示为粗体。

Recommended Starting Speeds [m/min]																						
Material Group	K313			KCU10/KC5010		KCU25/KC5025			KCP10		KCP25		KCK20B		KY3500							
P	0-1	-	-	140	280	335	110	225	270	185	400	450	145	290	365	200	440	490	-	-	-	
	2	-	-	140	200	245	110	160	195	185	270	350	145	200	305	200	300	380	-	-	-	
	3	-	-	140	155	245	110	125	195	170	190	260	140	155	245	600	200	280	-	-	-	
	4	-	-	75	110	170	60	90	135	90	145	200	75	110	180	100	160	220	-	-	-	
	5	-	-	120	200	260	100	160	210	150	220	305	120	200	270	165	240	330	-	-	-	
	6	-	-	110	150	230	85	120	185	120	180	275	110	150	230	130	190	300	-	-	-	
M	1	60	90	120	140	210	260	90	170	245	-	-	-	-	-	-	-	-	-	-	-	
	2	45	75	110	120	200	245	90	150	245	-	-	-	-	-	-	-	-	-	-	-	
	3	35	65	100	120	180	245	90	140	210	-	-	-	-	-	-	-	-	-	-	-	
K	1	30	75	120	120	180	245	100	145	195	170	245	440	140	200	360	210	305	550	180	760	1040
	2	25	70	110	90	150	210	70	120	170	120	195	340	100	160	280	150	245	430	275	365	500
	3	20	60	90	60	110	150	50	85	120	120	170	270	100	140	220	150	210	335	-	-	-
N	1-2	150	370	610	150	550	975	120	440	780	-	-	-	-	-	-	-	-	-	-	-	
	3	-	-	-	B	-	-	-	-	-	-	-	-	-	-	-	-	-	-	-	-	
	4	120	275	430	120	365	610	100	290	490	-	-	-	-	-	-	-	-	-	-	-	
	5	45	90	150	90	170	245	70	135	195	-	-	-	-	-	-	-	-	-	-	-	
	6	40	75	150	120	210	305	100	170	245	-	-	-	-	-	-	-	-	-	-	-	
	7	30	60	120	90	150	210	70	120	170	-	-	-	-	-	-	-	-	-	-	-	
S	1	8	30	75	15	55	135	8	40	60	-	-	-	-	-	-	-	-	-	-	-	
	2	8	35	75	15	60	135	8	30	75	-	-	-	-	-	-	-	-	-	-	-	
	3	8	40	75	15	70	135	15	40	75	-	-	-	-	-	-	-	-	-	-	-	
	4	8	45	75	15	70	170	8	50	110	-	-	-	-	-	-	-	-	-	-	-	
H	1	-	-	-	30	45	60	-	-	-	-	-	-	-	-	-	-	-	-	-	-	
	2	-	-	-	15	30	45	-	-	-	-	-	-	-	-	-	-	-	-	-	-	
	3	-	-	-	-	-	-	-	-	-	-	-	-	-	-	-	-	-	-	-	-	
	4	-	-	-	-	-	-	-	-	-	-	-	-	-	-	-	-	-	-	-	-	

■ 步骤四 • 根据应用种类选择刀柄

根据自己特定的切槽或切断加工应用，
以及相应的安装座尺寸选择高性能的刀柄产品。

	常规刀柄	模块化刀板
O.D.切槽、切断，以及车削刀具	第一选择	第二选择
端面切槽	第一选择	第二选择
内圆加工切槽、切断，以及车削刀具	第一选择	-

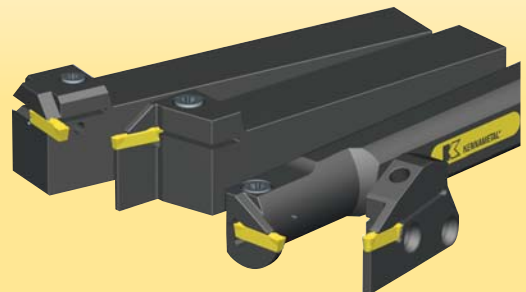

注：刀片尺寸必须与刀柄上的刀座尺寸匹配。

■ 步骤五 • 从产品目录中选择刀片和刀柄

祝贺您！

根据加工应用的特点，您已经成功选择了最佳的刀片、槽型、材质、以及切削参数，使刀具的加工效率达到了最优化！

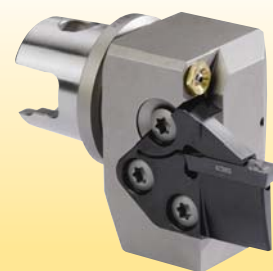

如何使用目录编号？

产品目录中的每一个字符都表示产品的一个具体特征。利用下面的栏框以及对应的图形，可以容易地找到适用的刀具参数值。

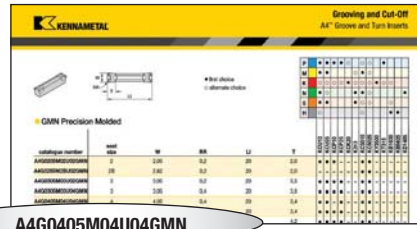

A4G0405M04U04GMN

切槽及车削刀片

A4 刀柄系统 A4 = 切槽与车削	G 刀片类型 G = 平面 R = 圆角 C = 切断加工	0405 切槽宽度 按 1/100mm 或 .00" 表示	M 切槽宽度的度量单位 M = 公制	04 安装座尺寸	U 刀片公差	04 刀尖半径	GMN 断屑器类型/刃口处理 GMN = 切槽及车削一般加工坚固型切削刃 GMP = 切槽及车削一般加工正前角 GUP = 切槽及车削大正前角特别适合于不锈钢及高温合金工件的加工 B = 用于特别形状和加工类型的平板刀具 E = 平板型，轻微倒圆切削刃 S = 负倒棱加倒圆 ST = 单刃
---------------------------------	--	--	---------------------------------	--------------------	------------------	-------------------	--

刀窝安装座尺寸	切削宽度 (mm)
02	2,00-2,62
2B	2,39-2,62
03	3,0-3,05
04	4,0-4,05
05	5,0-5,05
06	6,0-6,05
08	8,0-8,05
10	10,0-10,05
2S	2,00-2,62
3S	3,00-3,05
4S	4,00-4,05
5S	5,00-5,05

P = 精磨切槽刀具宽度公差: ± .001" (0,025mm)

U = 整体压铸切槽刀具宽度公差:

3,05-4,05:	+0,15mm
	-0
5,05-10,05:	+0,25mm
	-0

公制

01 = 0,1
02 = 0,2
04 = 0,4
08 = 0,8
12 = 1,2
圆角 = 00

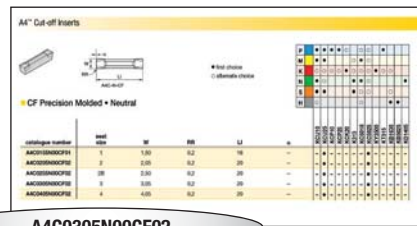

A4C0305N00CF02

切槽及切断

A4 刀柄系统 A4 = 切槽与车削	C 刀片类型 C = 切断	0305 切削宽度 按 1/100mm 表示	N 刀片方向 R = 右手 L = 左手 N = 中置	00 主切削刃的主偏角 00 = 中置 06 = 6° 10 = 10°	CF 断屑器槽型 CF = 切断刀片正前角	02 圆角型 公制 02 = 0,2
---------------------------------	----------------------------	-------------------------------------	--	---	------------------------------------	------------------------------------

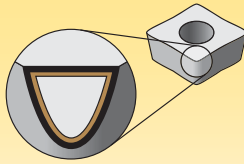

涂层更适合高速加工，并且可用于精加工至轻型粗加工应用范围。

P	钢
M	不锈钢
K	铸铁
N	非铁金属
S	高温合金
H	硬材料

耐磨性 ←————→ 韧性

材质

涂层	材质说明		05	10	15	20	25	30	35	40	45
KCU10	 <p>成分：一种先进的PVD复合涂层材质，基体为一种具有强抗变形能力的非合金碳化物。这种经过改良的新型涂层可以提高刃口的稳定性，并可用于多种切削速度和进给量的加工。 应用：KCU10™ 是对多种工件材料进行精加工至一般加工的理想材质，在加工过程中可采用多种切削速度和进给量。在多种钢材料、不锈钢材料、铸铁材料、非铁金属材料、以及超级合金材料的加工中具有卓越的性能；具有更好的刃口韧性，抗切深处磨损，以及更高的切削速度/进给率性能。</p>	P									
		M									
		K									
		N									
		S									
		H									
											
KCU25	 <p>成分：一种高级 PVD 材质，采用硬质 AlTiN 涂层，以及细晶粒的非合金基体。这种经过改良的新型涂层可以提高刃口的稳定性，并可用于多种切削速度和进给量的加工。 应用：KCU25™ 材质是用于多种钢材料、不锈钢、高温合金、钛、铁，以及非铁金属材料通用加工的理想材质；可采用多种切削速度和进给率进行加工，刃口具有更好的韧性，可进行高进给断续切削加工。</p>	P									
		M									
		K									
		N									
		S									
											
KCP10	 <p>成分：一种特别设计的高钴硬质合金材质，以及具有出色抗磨损性能的 MTCVD TiCN-Al₂O₃ 厚涂层。 应用：用于对多种工件材料，包括钢材料、铁素体、马氏体、PH不锈钢，以及铸铁材料进行精加工至一般加工的应用范围。钴基材料基体在抗变形性能和刀刃韧性之间有着良好的平衡性，厚涂层在高速切削中具有出色的耐磨性和抗月牙洼磨损性。光滑的涂层表面可以避免出现积屑瘤和微崩刃现象，并具有出色的表面精加工性能。</p>	P									
		K									
											
KCP25	 <p>成分：一种韧性很好的高钴硬质合金材质，以及具有出色涂层间粘着性的 MTCVD TiCN-Al₂O₃ 复合涂层。 应用：是用于对多种钢材料、铁素体和马氏体不锈钢材料进行通用车削加工的最佳刀片材质。基体具有足够的抗变形性能，并具有出色的刀片刃口强度。复合涂层在多种切削条件下具有良好的耐磨性，涂层去应力处理工艺减少了微崩刃现象，提高了涂层与基体间的粘着性能，从而延长了刀具的使用寿命，并改善了工件的精加工质量。</p>	P									
		K									
											
KCK20	 <p>成分：一种经过特别增加韧性处理的 MTCVD TiCN-Al₂O₃ 涂层，基体具有很好的耐磨性。 应用：增加了涂层的粘着性以及刀刃的强度，是对灰铸铁和球墨铸铁材料进行湿式断续切削的理想材质。这种材质的应用范围广泛，从精加工至粗加工，在对刀具强度和加工可靠性有较高要求的加工中有非常出色的加工效率。</p>	P									
		K									
											

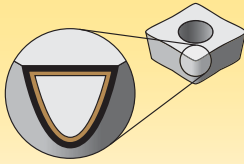

涂层更适合高速加工，并且可用于精加工至轻型粗加工应用范围。

P	钢
M	不锈钢
K	铸铁
N	非铁金属
S	高温合金
H	硬材料

耐磨性 ←————→ 韧性

材质

涂层	材质说明		05	10	15	20	25	30	35	40	45	
K313	成分：一种硬的，含有较少粘结剂的，WC/Co 非合金细晶粒材质。 应用：在切削钛、铸铁、奥氏体不锈钢、非铁金属、非金属、以及高温合金材料工件时，具有出色的抗刃口磨损性能，以及很高的强度。具有出色的抗热变形和抗切深处破损的性能。晶粒结构的控制非常出色，避免出现微小凹陷和瑕疵，从而具有更长的使用寿命，以及更可靠的性能。											
		M										
		K										
		N										
		S										
KC5010	成分：一种先进的PVD AlTiN涂层材质，基体为一种具有强抗变形能力的非合金碳化物。 应用：KC5010™ 材质适合多种工件材料的精加工和一般加工。在多种钢材料、不锈钢材料、铸铁材料、非铁金属材料、以及高温合金材料的稳定工况加工中具有卓越的性能。并且在硬化材料和短切屑材料的加工中同样具有很好的性能。	P										
		M										
		K										
		N										
		S										
		H										
KC5025	成分：一种高级PVD AlTiN涂层材料，基体为一种具有韧性，超细晶粒的非合金物质。 应用：用于对多种钢材料、不锈钢、高温合金、钛、铁、以及非铁金属材料进行通用加工。切削速度可以从低速到中速，并且可以进行大进给断续切削。	P										
		M										
		K										
		N										
		S										

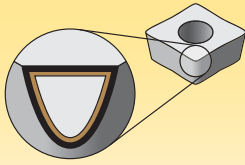

涂层更适合高速加工，并且可用于精加工至轻型粗加工应用范围。

P	钢
M	不锈钢
K	铸铁
N	非铁金属
S	高温合金
H	硬材料

耐磨性 ←————→ 韧性

材质

涂层	材质说明		05	10	15	20	25	30	35	40	45
KY3500	<p>成分：纯氮化硅的材质。</p> <p>应用：具有出色的韧性。用于对灰铸铁材料进行大进给的粗加工，包括断续切削加工。</p>										
		K									
KT315	<p>成分：一种采用 PVD-TiN/TiCN/TiN 复合涂层的金属陶瓷车刀材质。</p> <p>应用：用于对多种碳材料、合金材料、以及不锈钢材料进行高速切削精加工和一般加工。在铸造件和球墨铸铁材料加工中同样具有出色的加工性能。具有超长并稳定的刀具寿命，并具有卓越的工件精加工性能。</p>	P									
		K									
KB1630	<p>成分：一种非涂层高 PcBN 含量的材质。PcBN 刃口钎焊至硬质合金刀片上。</p> <p>应用：用于对硬化钢材料（硬度大于45 HRC）进行断续切削的粗加工至精加工应用。同时还可用于灰铸铁、冷硬铁、高铬合金钢、高温合金以及烧结粉末金属材料的加工。PcBN 焊刃刀片有多种刀片类型，包括 Top Notch™ 和螺纹接口槽型。</p>										
		K									
		S									
		H									
KB5625	<p>成分：一种一般含量的 PcBN 材质，PVD TiN/AlTiN 涂层具有更高的耐磨性。</p> <p>应用：用于对硬化钢材料（硬度大于45 HRC）进行粗加工。适合轴承钢、热作及冷作钢、模具钢、表面硬化钢、碳化铁、氮化铁、以及一些硬涂层工件的加工。</p>										
		H									
KD1405	<p>成分：一种将纯 CVD 材料熔敷至金刚石片上的材质，并直接钎焊至硬质合金材料的基体上。</p> <p>应用：KD1405™ 是肯纳金属公司研发的抗磨损性能最佳的刀具材质，可用于非铁材料和非金属材料的加工。特别适合对耐磨性要求极高的加工应用。</p>										
		N									

■ 选择槽型

P	钢
M	不锈钢
K	铸铁
N	非铁金属
S	高温合金
H	硬材料

- 首选
- 备选

断屑槽	描述	刀片槽型	刀座尺寸	圆角半径		初始条件						
				mm	mm	径向进给率 mm/rev						
						0,05	0,10	0,15	0,20	0,25	0,30	0,35
-GUP	新型 Beyond™ 材质的切槽及车削刀片。		2	0,2	0,08	0,05	0,10	0,15	0,20	0,25	0,30	0,35
				0,2	0,09	0,05	0,10	0,15	0,20	0,25	0,30	0,35
			3	0,4	0,11	0,05	0,10	0,15	0,20	0,25	0,30	0,35
				0,4	0,12	0,05	0,10	0,15	0,20	0,25	0,30	0,35
				0,8	0,15	0,05	0,10	0,15	0,20	0,25	0,30	0,35

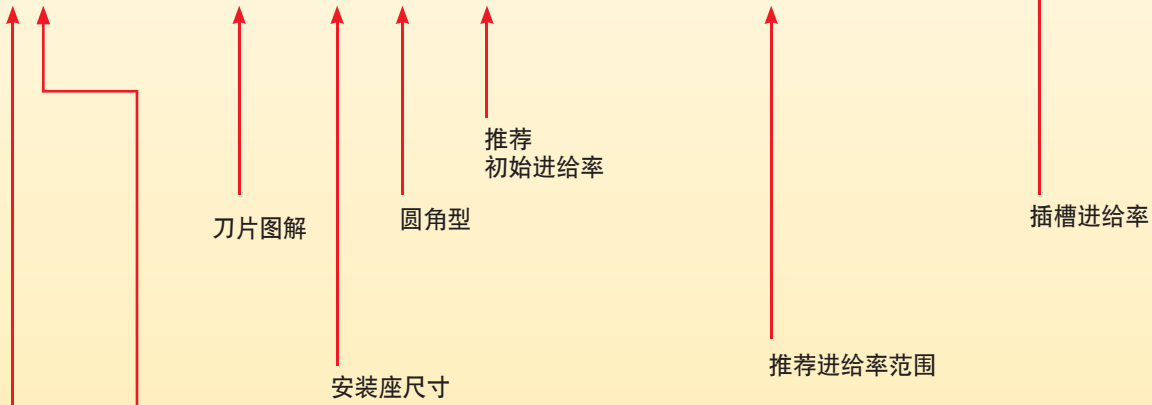

主要工件材料组

P	钢
M	不锈钢
K	铸铁
N	非铁金属
S	高温合金
H	硬材料

- 首选
- 备选

切屑控制槽型设计

最大进给率参数

以上参数适用于 P 组和 K 组材料。对于以下相关材料组中的材料，其最大进给率的调整需乘以相应的系数。	材料分组	进给率系数
	M	.8
	N	1.2
	S	.8
	H	.5

■ 插铣进给率

- 首选
- 备选

P	钢
M	不锈钢
K	铸铁
N	非铁金属
S	高温合金
H	硬材料

断屑槽	描述	刀片槽型	刀座尺寸	圆角半径	初始条件	径向进给率 mm/rev									
						mm	mm	0,05	0,10	0,15	0,20	0,25	0,30	0,35	
								[进给率范围图]							
-GUP	<ul style="list-style-type: none"> ● 新型 Beyond™ 材质的切槽及车削刀片。 ● 提供经模制和精磨的产品。 ● 提高切屑控制性能的正角产品。 ● 仅提供公制宽度产品。 		2	0,2	0,08	[进给率范围图]									
				0,2	0,09	[进给率范围图]									
			3	0,4	0,11	[进给率范围图]									
				0,4	0,12	[进给率范围图]									
			4	0,8	0,15	[进给率范围图]									
				0,4	0,15	[进给率范围图]									
			5	0,8	0,16	[进给率范围图]									
				0,4	0,16	[进给率范围图]									
			6	0,8	0,18	[进给率范围图]									
				1,2	0,20	[进给率范围图]									
			8	0,4	0,17	[进给率范围图]									
				0,8	0,20	[进给率范围图]									
			10	1,2	0,22	[进给率范围图]									
				0,4	0,18	[进给率范围图]									
			-GMP	<ul style="list-style-type: none"> ● 切槽及车削刀片。 ● 提供经模制和精磨的产品。 ● 正前角。 ● 仅提供公制宽度产品。 		2	0,2	0,08	[进给率范围图]						
							0,2	0,09	[进给率范围图]						
						3	0,4	0,11	[进给率范围图]						
							0,4	0,12	[进给率范围图]						
4	0,8	0,15				[进给率范围图]									
	0,4	0,15				[进给率范围图]									
5	0,8	0,16				[进给率范围图]									
	0,4	0,16				[进给率范围图]									
6	0,8	0,18				[进给率范围图]									
	1,2	0,20				[进给率范围图]									
8	0,4	0,17				[进给率范围图]									
	0,8	0,20				[进给率范围图]									
10	1,2	0,22				[进给率范围图]									
	0,4	0,18				[进给率范围图]									
-GMN	<ul style="list-style-type: none"> ● 经模制和精磨的切槽及车削刀片。 ● 坚固的切削刃。 ● 可提供公制及英制宽度产品。 					2	0,2	0,08	[进给率范围图]						
							0,2	0,09	[进给率范围图]						
						3	0,4	0,11	[进给率范围图]						
							0,4	0,12	[进给率范围图]						
			4	0,8	0,15	[进给率范围图]									
				0,4	0,15	[进给率范围图]									
			5	0,8	0,16	[进给率范围图]									
				0,4	0,16	[进给率范围图]									
			6	0,8	0,18	[进给率范围图]									
				1,2	0,20	[进给率范围图]									
			8	0,4	0,17	[进给率范围图]									
				0,8	0,20	[进给率范围图]									
			10	1,2	0,22	[进给率范围图]									
				0,4	0,18	[进给率范围图]									

最大进给率参数

这些参数适用于 P 组和 K 组材料。根据其它材料组中的参数增加最大进给率，从而实现最大进给率的调整。

材料分组	进给率系数
M	.8
N	.8
S	.5
H	1.2

内圆及端面切槽

在内圆及端面切槽加工中，进给率降低 20%。

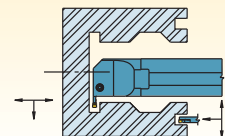

■ 车削及仿形加工进给率 • GUP/GMP 槽型

安装座尺寸 2

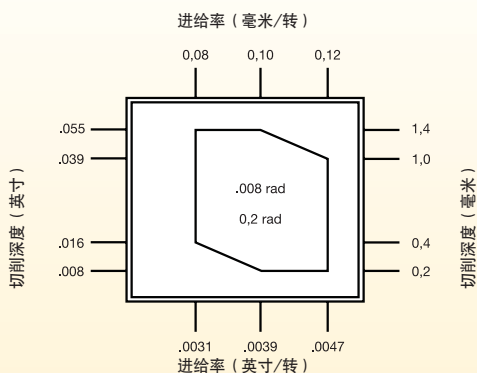

安装座尺寸 3

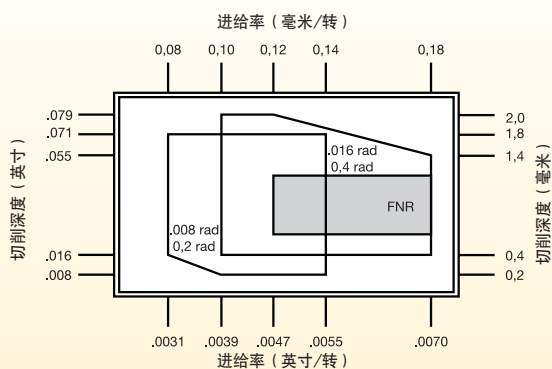

安装座尺寸 4

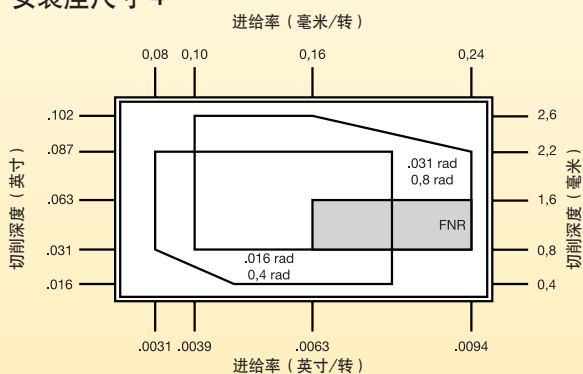

安装座尺寸 5

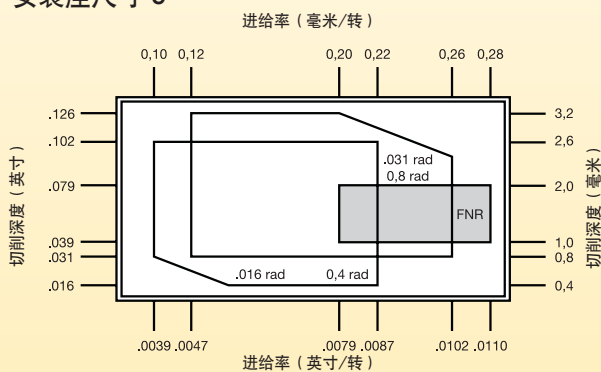

安装座尺寸 6

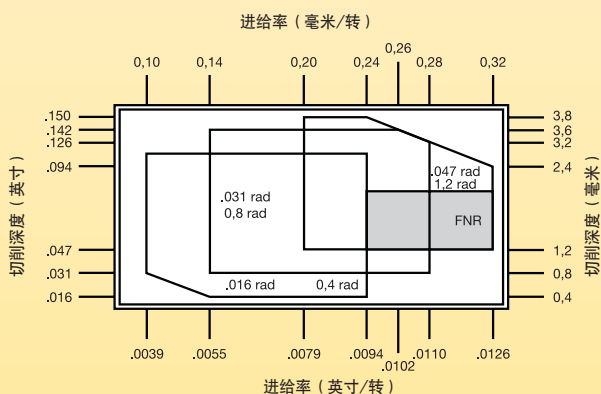

安装座尺寸 8

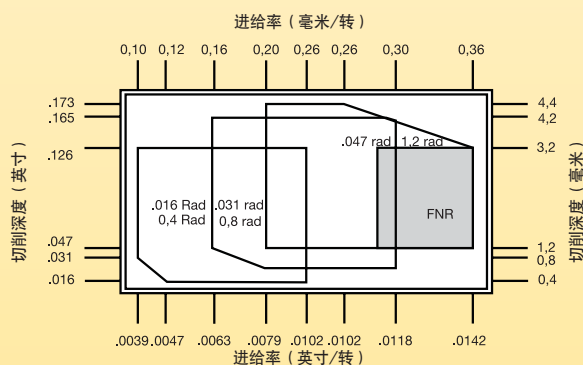

安装座尺寸 10

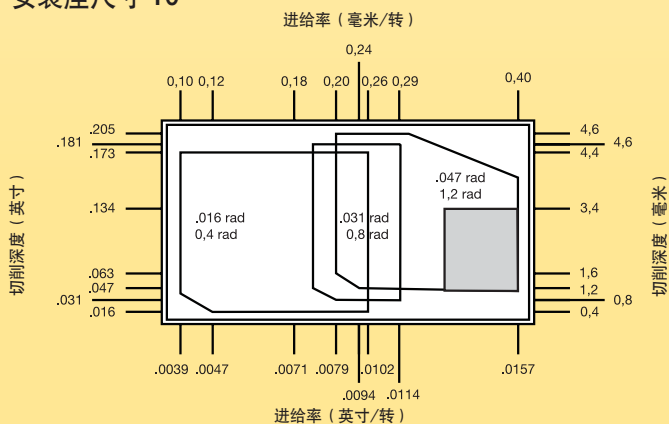

■ 车削及仿形加工进给率 • GMN 槽型

安装座尺寸 2

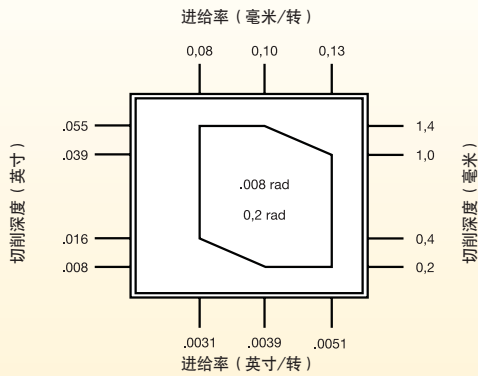

安装座尺寸 3

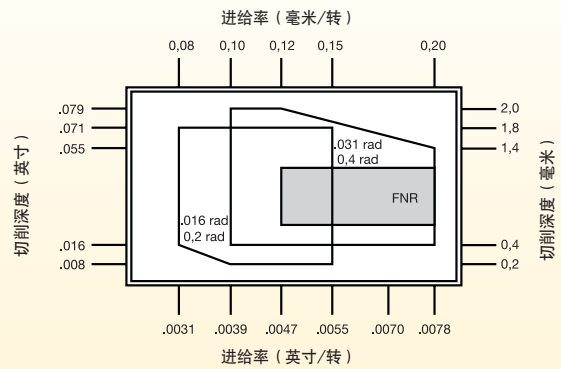

安装座尺寸 4

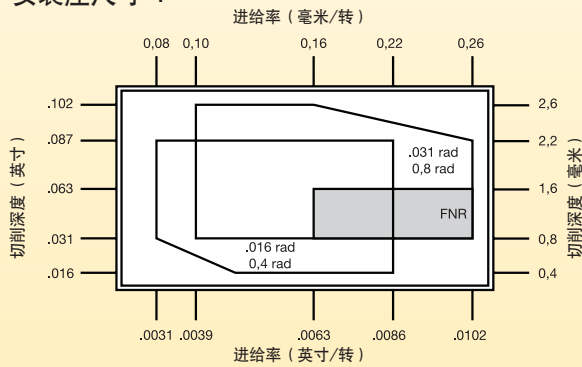

安装座尺寸 5

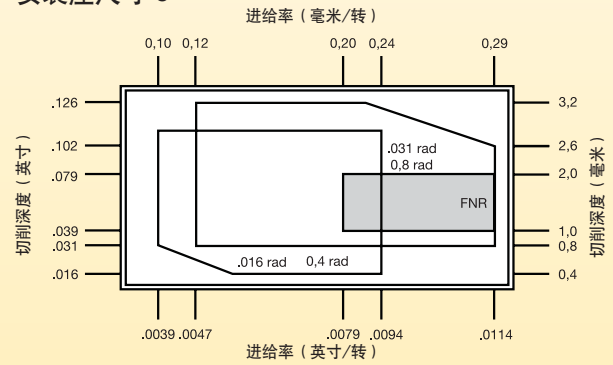

安装座尺寸 6

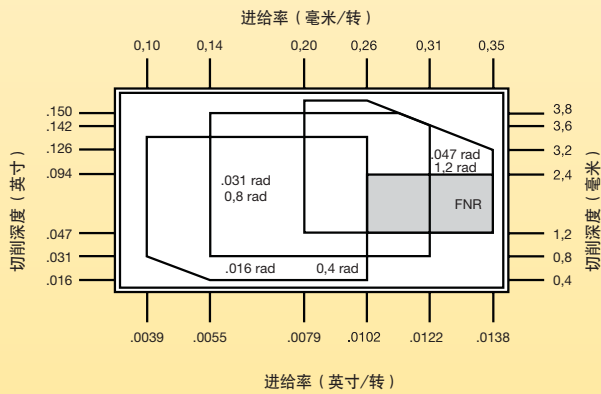

安装座尺寸 8

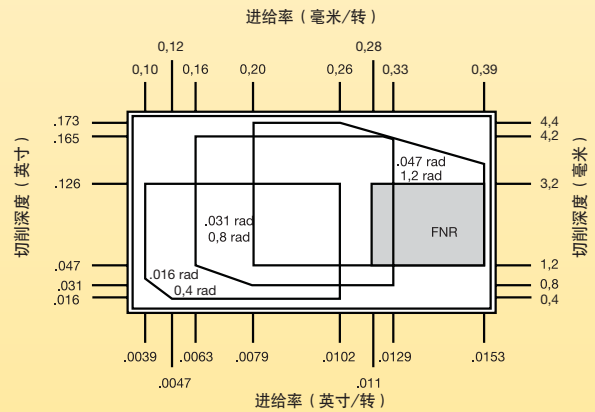

安装座尺寸 10

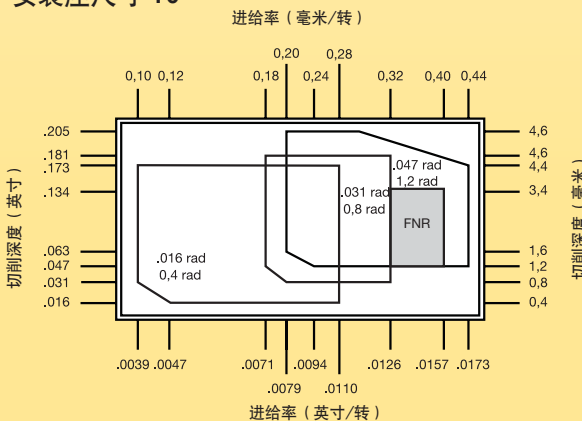

■ 切断加工进给率

P	钢
M	不锈钢
K	铸铁
N	非铁金属
S	高温合金
H	硬材料

- 首选
- 备选

断屑槽	描述	刀片槽型	刀座尺寸	初始条件 mm	切断加工进给率 mm/rev			
					0,05	0,10	0,15	0,20
-A4C-CF 	<ul style="list-style-type: none"> 使用正前角。 尖角型切削刃。 可以提供中置刀具，主偏角为6°和10°的右手及左手类型。 		1	0,06				
			2/2B	0,07				
			3	0,09				
			4	0,11				

最大进给率参数

这些参数适用于 P 组和 K 组材料。根据其它材料组中的参数增加最大进给率，从而实现最大进给率的调整。	材料分组	进给率系数
	M	.8
	N	.8
	S	.5
	H	1.2

应用设备应用程序

肯纳公司移动应用程序，可在iPhone® 和Android™设备方便地访问产品信息。我们已经列出了的一些关键特性.....

这个应用程序给您带来便利！

- 速度和进给**
为金属加工产品查看速度和反馈信息。
- 产品可用性**
通过提供你的e-Konnect登录，全球范围内查看可库存的产品及数量
- 计算**
利用计算器算出铣削和钻削的应用参数。

➔ 通过扫描刀片包装上的条形码,您可以获得的切削刀具寿命、加工时间,切屑控制的信息。

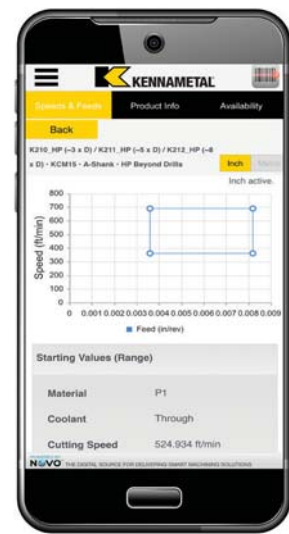

注意: 目前应用程序目前仅提供英文版本。其它语言的版本已在计划中



■ 推荐初始切削速度[m/min]

材料分组		K313	KCU10/KC5010	KCU25/KC5025	KCP10	KCP25	KCK20B	KY3500
P	0-1	- - -	140 280 335	110 225 270	185 400 450	145 290 365	200 440 490	- - -
	2	- - -	140 200 245	110 160 195	185 270 350	145 200 305	200 300 380	- - -
	3	- - -	140 155 245	110 125 195	170 190 260	140 155 245	600 200 280	- - -
	4	- - -	75 110 170	60 90 135	90 145 200	75 110 180	100 160 220	- - -
	5	- - -	120 200 260	100 160 210	150 220 305	120 200 270	165 240 330	- - -
	6	- - -	110 150 230	85 120 185	120 180 275	110 150 230	130 190 300	- - -
M	1	60 90 120	140 210 260	90 170 245	- - -	- - -	- - -	- - -
	2	45 75 110	120 200 245	90 150 245	- - -	- - -	- - -	- - -
	3	35 65 100	120 180 245	90 140 210	- - -	- - -	- - -	- - -
K	1	30 75 120	120 180 245	100 145 195	170 245 440	140 200 360	210 305 550	180 760 1040
	2	25 70 110	90 150 210	70 120 170	120 195 340	100 160 280	150 245 430	275 365 500
	3	20 60 90	60 110 150	50 85 120	120 170 270	100 140 220	150 210 335	- - -
N	1-2	150 370 610	150 550 975	120 440 780	- - -	- - -	- - -	- - -
	3	- - -	- - -	- - -	- - -	- - -	- - -	- - -
	4	120 275 430	120 365 610	100 290 490	- - -	- - -	- - -	- - -
	5	45 90 150	90 170 245	70 135 195	- - -	- - -	- - -	- - -
	6	40 75 150	120 210 305	100 170 245	- - -	- - -	- - -	- - -
	1	8 30 75	15 55 135	8 40 60	- - -	- - -	- - -	- - -
S	2	8 35 75	15 60 135	8 30 75	- - -	- - -	- - -	- - -
	3	8 40 75	15 70 135	15 40 75	- - -	- - -	- - -	- - -
	4	8 45 75	15 70 170	8 50 110	- - -	- - -	- - -	- - -
	1	- - -	30 45 60	- - -	- - -	- - -	- - -	- - -
H	2	- - -	15 30 45	- - -	- - -	- - -	- - -	- - -
	3	- - -	- - -	- - -	- - -	- - -	- - -	- - -
	4	- - -	- - -	- - -	- - -	- - -	- - -	- - -

切槽及切断

材料分组		KT315	KB5625	KB1630	KD1405
P	0-1	180 440 475	- - -	- - -	- - -
	2	195 270 400	- - -	- - -	- - -
	3	180 210 275	- - -	- - -	- - -
	4	75 160 210	- - -	- - -	- - -
	5	150 250 310	- - -	- - -	- - -
	6	140 200 300	- - -	- - -	- - -
M	1	- - -	- - -	- - -	- - -
	2	- - -	- - -	- - -	- - -
	3	- - -	- - -	- - -	- - -
K	1	60 275 550	- - -	180 760 1040	- - -
	2	135 275 360	- - -	- - -	- - -
	3	180 230 360	- - -	- - -	- - -
N	1-2	- - -	- - -	- - -	365 610 1040
	3	- - -	- - -	- - -	275 480 800
	4	- - -	- - -	- - -	300 550 920
	5	- - -	- - -	- - -	275 610 1070
	6	- - -	- - -	- - -	150 460 760
	1	- - -	- - -	120 200 275	- - -
S	2	- - -	- - -	120 215 275	- - -
	3	- - -	- - -	120 250 275	- - -
	4	- - -	- - -	- - -	- - -
	1	- - -	45 150 230	45 120 170	- - -
H	2	- - -	45 140 230	45 110 170	- - -
	3	- - -	45 130 230	45 100 170	- - -
	4	- - -	45 120 230	45 90 170	- - -

注: 首选初始切削速度为粗体字。
在切屑平均厚度增加情况下, 应降低切削速度。

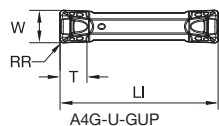
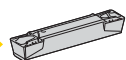

● 首选
○ 备选

■ GUP 精密压铸

目录编号	刀片尺寸	W	RR	LI	T	KCU10	KCU25	KCP10	KCP25	KCK20	K313	KC5010	KC5025	KY3500	KT315	KB1630	KB5625	KD1405	
A4G0205M02U02GUP	2	2,05	0,2	20	2,0	●	●	●	●	○	○	○	○	○	○	○	○	○	○
A4G0305M03U02GUP	3	3,05	0,2	20	3,0	●	●	●	●	○	○	○	○	○	○	○	○	○	○
A4G0305M03U04GUP	3	3,05	0,4	20	3,0	●	●	●	●	○	○	○	○	○	○	○	○	○	○
A4G0405M04U04GUP	4	4,05	0,4	20	3,4	●	●	●	●	○	○	○	○	○	○	○	○	○	○
A4G0405M04U08GUP	4	4,05	0,8	20	3,4	●	●	●	●	○	○	○	○	○	○	○	○	○	○
A4R0405M04U00GUP	4	4,05	—	20	—	—	●	—	—	—	—	—	—	—	—	—	—	—	—
A4G0505M05U04GUP	5	5,05	0,4	25	4,2	●	●	●	●	○	○	○	○	○	○	○	○	○	○
A4G0505M05U08GUP	5	5,05	0,8	25	4,2	●	●	●	●	○	○	○	○	○	○	○	○	○	○
A4G0605M06U04GUP	6	6,05	0,4	30	4,5	●	●	●	●	○	○	○	○	○	○	○	○	○	○
A4G0605M06U08GUP	6	6,05	0,8	30	4,5	●	●	●	●	○	○	○	○	○	○	○	○	○	○
A4G0605M06U12GUP	6	6,05	1,2	30	4,5	●	●	●	●	○	○	○	○	○	○	○	○	○	○
A4R0605M06U00GUP	6	6,05	—	30	4,9	—	●	—	—	—	—	—	—	—	—	—	—	—	—
A4G0805M08U08GUP	8	8,05	0,8	30	6,0	●	●	●	●	○	○	○	○	○	○	○	○	○	○
A4G0805M08U12GUP	8	8,05	1,2	30	6,0	●	●	●	●	○	○	○	○	○	○	○	○	○	○
A4R0805M08U00GUP	8	8,05	—	30	6,5	—	●	—	—	—	—	—	—	—	—	—	—	—	—
A4G1005M10U08GUP	10	10,05	0,8	30	6,0	●	●	●	●	○	○	○	○	○	○	○	○	○	○
A4G1005M10U12GUP	10	10,05	1,2	30	6,1	—	●	—	—	—	—	—	—	—	—	—	—	—	—

P	●	●	●	●	○	○	○	○	○	○	○	○	○	○	○	○	○	○	○
M	●	●	○	○	○	○	○	○	○	○	○	○	○	○	○	○	○	○	○
K	○	○	○	○	○	○	○	○	○	○	○	○	○	○	○	○	○	○	○
N	●	○	○	○	○	○	○	○	○	○	○	○	○	○	○	○	○	○	○
S	●	●	○	○	○	○	○	○	○	○	○	○	○	○	○	○	○	○	○
H	○	○	○	○	○	○	○	○	○	○	○	○	○	○	○	○	○	○	○

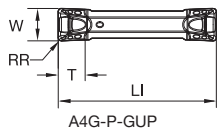
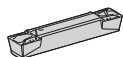

● 首选
○ 备选

■ GUP 精磨

目录编号	刀片尺寸	W	RR	LI	T	KCU10	KCU25	KCP10	KCP25	KCK20	K313	KC5010	KC5025	KY3500	KT315	KB1630	KB5625	KD1405
A4G0200M02P02GUP	2	2,00	0,2	20	1,9	●	●	-	-	-	-	-	-	-	-	-	-	-
A4G094I2BP05GUP	2B	2,38	0,2	20	1,9	-	●	-	-	-	-	-	-	-	-	-	-	-
A4G0300M03P02GUP	3	3,00	0,2	20	2,9	●	●	-	-	-	-	-	-	-	-	-	-	-
A4G0300M03P04GUP	3	3,00	0,4	20	2,9	●	●	-	-	-	-	-	-	-	-	-	-	-
A4G125I03P05GUP	3	3,18	0,2	20	2,9	-	●	-	-	-	-	-	-	-	-	-	-	-
A4G125I03P1GUP	3	3,18	0,4	20	2,9	-	●	-	-	-	-	-	-	-	-	-	-	-
A4G0400M04P02GUP	4	4,00	0,2	20	3,3	●	●	-	-	-	-	-	-	-	-	-	-	-
A4G0400M04P04GUP	4	4,00	0,4	20	3,3	●	●	-	-	-	-	-	-	-	-	-	-	-
A4G0400M04P08GUP	4	4,00	0,8	20	3,3	●	●	-	-	-	-	-	-	-	-	-	-	-
A4G187I04P1GUP	4	4,76	0,4	20	3,3	-	●	-	-	-	-	-	-	-	-	-	-	-
A4G0500M05P04GUP	5	5,00	0,4	25	4,1	●	●	-	-	-	-	-	-	-	-	-	-	-
A4G0500M05P08GUP	5	5,00	0,8	25	4,1	●	●	-	-	-	-	-	-	-	-	-	-	-
A4G0600M06P04GUP	6	6,00	0,4	30	4,5	●	●	-	-	-	-	-	-	-	-	-	-	-
A4G0600M06P08GUP	6	6,00	0,8	30	4,5	●	●	-	-	-	-	-	-	-	-	-	-	-
A4G25I06P1GUP	6	6,35	0,4	30	4,4	-	●	-	-	-	-	-	-	-	-	-	-	-
A4G25I06P2GUP	6	6,35	0,8	30	4,4	-	●	-	-	-	-	-	-	-	-	-	-	-
A4G312I08P1GUP	8	7,94	0,4	30	5,9	-	●	-	-	-	-	-	-	-	-	-	-	-
A4G0800M08P08GUP	8	8,00	0,8	30	6,0	●	●	-	-	-	-	-	-	-	-	-	-	-
A4G0800M08P12GUP	8	8,00	1,2	30	6,0	●	●	-	-	-	-	-	-	-	-	-	-	-
A4G375I10P1GUP	10	9,53	0,4	30	5,9	-	●	-	-	-	-	-	-	-	-	-	-	-
A4G1000M10P08GUP	10	10,00	0,8	30	6,0	●	●	-	-	-	-	-	-	-	-	-	-	-
A4G1000M10P12GUP	10	10,00	1,2	30	6,0	●	●	-	-	-	-	-	-	-	-	-	-	-

切槽及切断

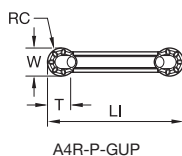
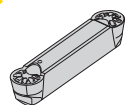

A4R-P-GUP

■ GUP 圆角精密压铸

目录编号	刀片尺寸	W	RC	LI	T
A4R0305M03U00GUP	3	3,05	1,5	20	—
A4R0505M05U00GUP	5	5,05	2,5	25	—
A4R1005M10U00GUP	10	10,05	5,0	30	—

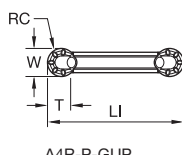
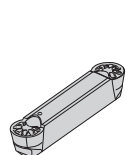

A4R-P-GUP

■ GUP 圆角精磨

目录编号	刀片尺寸	W	RC	LI	T
A4R0300M03P00GUP	3	3,00	1,5	20	—
A4R125I03P00GUP	3	3,18	1,6	20	—
A4R0400M04P00GUP	4	4,00	2,0	20	—
A4R187I04P00GUP	4	4,76	2,4	20	—
A4R0500M05P00GUP	5	5,00	2,5	25	—
A4R0600M06P00GUP	6	6,00	3,0	30	—
A4R250I06P00GUP	6	6,35	3,2	30	—
A4R312I08P00GUP	8	7,94	4,0	30	—
A4R0800M08P00GUP	8	8,00	4,0	30	—
A4R1000M10P00GUP	10	10,00	5,0	30	—

● 首选
○ 备选

	P	M	K	N	S	H	KCU10	KCU25	KCP10	KCP25	KCK20	K313	KC5010	KC5025	KY3500	KT315	KB1630	KB5625	KD1405	
● 首选	●	●	●	○	○	○	●	●	●	●	●	○	○	○	○	○	○	○	○	○
○ 备选	○	○	○	○	○	○	○	○	○	○	○	○	○	○	○	○	○	○	○	○



切槽及切断

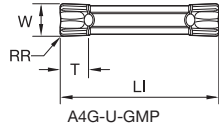
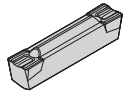

A4G-U-GMP

■ GMP 精密压铸

目录编号	刀片尺寸	W	RR	LI	T	KCU10	KCU25	KCP10	KCP25	KCK20	K313	KC5010	KC5025	KY3500	KT315	KB1630	KB5625	KD1405
A4G0205M02U02GMP	2	2,05	0,2	20	2,0	-	●	-	-	-	-	○	○	-	-	-	-	-
A4G0255M2BU02GMP	2B	2,62	0,2	20	2,0	-	●	-	-	-	-	○	○	-	-	-	-	-
A4G0305M03U02GMP	3	3,05	0,2	20	3,5	●	●	-	-	-	-	●	●	-	-	-	-	-
A4G0305M03U04GMP	3	3,05	0,4	20	3,5	●	●	-	-	-	-	●	●	-	-	-	-	-
A4G0405M04U04GMP	4	4,05	0,4	20	3,4	●	●	●	-	-	-	●	●	-	-	-	-	-
A4G0405M04U08GMP	4	4,05	0,8	20	3,4	-	●	-	-	-	-	●	●	-	●	-	-	-
A4G0505M05U04GMP	5	5,05	0,4	25	4,2	●	●	●	-	-	-	●	●	-	-	-	-	-
A4G0505M05U08GMP	5	5,05	0,8	25	4,2	-	●	●	-	-	-	●	●	-	-	-	-	-
A4G0605M06U04GMP	6	6,05	0,4	30	4,9	-	-	-	●	-	-	●	●	-	-	-	-	-
A4G0605M06U08GMP	6	6,05	0,8	30	4,9	-	-	-	-	-	-	●	●	-	-	-	-	-
A4G0805M08U08GMP	8	8,05	0,8	30	6,1	-	●	-	-	-	-	●	●	-	-	-	-	-
A4G1005M10U08GMP	10	10,05	0,8	30	8,1	●	●	-	-	-	-	-	-	-	-	-	-	-

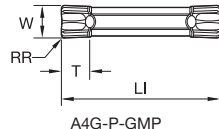
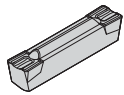

A4G-P-GMP

■ GMP 精磨

目录编号	刀片尺寸	W	RR	LI	T	KCU10	KCU25	KCP10	KCP25	KCK20	K313	KC5010	KC5025	KY3500	KT315	KB1630	KB5625	KD1405
A4G0200M02P02GMP	2	2,00	0,2	20	2,0	●	●	-	-	-	-	●	●	-	-	-	-	-
A4G0250M2BP02GMP	2B	2,50	0,2	20	2,0	●	-	-	-	-	-	●	-	-	-	-	-	-
A4G0300M03P02GMP	3	3,00	0,2	20	3,5	●	●	-	-	-	-	●	●	-	-	-	-	-
A4G0300M03P04GMP	3	3,00	0,4	20	3,5	●	●	-	-	-	-	●	●	-	-	-	-	-
A4G0400M04P02GMP	4	4,00	0,2	20	-	●	●	-	-	-	-	●	●	-	-	-	-	-
A4G0400M04P04GMP	4	4,00	0,4	20	3,5	●	●	-	-	-	-	●	●	-	-	-	-	-
A4G0400M04P08GMP	4	4,00	0,8	20	3,5	●	●	-	-	-	-	●	●	-	-	-	-	-
A4G0500M05P04GMP	5	5,00	0,4	25	-	●	●	-	-	-	-	●	●	-	-	-	-	-
A4G0500M05P08GMP	5	5,00	0,8	25	-	●	-	-	-	-	-	●	●	-	-	-	-	-
A4G0600M06P04GMP	6	6,00	0,4	30	4,9	●	●	-	-	-	-	●	●	-	-	-	-	-
A4G0600M06P08GMP	6	6,00	0,8	30	4,9	●	-	-	-	-	-	●	●	-	-	-	-	-
A4G0800M08P08GMP	8	8,00	0,8	30	6,4	-	●	-	-	-	-	●	●	-	-	-	-	-
A4G0800M08P12GMP	8	8,00	1,2	30	6,4	●	-	-	-	-	-	-	-	-	-	-	-	-

P	●	●	●	●	○	○	○	○	○	○	○	○	○	○	○	○	○	○	○
M	●	●	○	○	○	○	○	○	○	○	○	○	○	○	○	○	○	○	○
K	○	○	○	○	○	○	○	○	○	○	○	○	○	○	○	○	○	○	○
N	●	○	○	○	○	○	○	○	○	○	○	○	○	○	○	○	○	○	○
S	●	●	○	○	○	○	○	○	○	○	○	○	○	○	○	○	○	○	○
H	○	○	○	○	○	○	○	○	○	○	○	○	○	○	○	○	○	○	○

● 首选
○ 备选

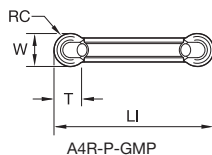
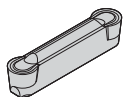

● 首选
○ 备选

P	●	●	●	○	○	○	○	○	○	○	○	○	○	○	○	○	○	○	○
M	●	●	○	○	○	○	○	○	○	○	○	○	○	○	○	○	○	○	○
K	○	○	○	○	○	○	○	○	○	○	○	○	○	○	○	○	○	○	○
N	●	○	○	○	○	○	○	○	○	○	○	○	○	○	○	○	○	○	○
S	●	●	○	○	○	○	○	○	○	○	○	○	○	○	○	○	○	○	○
H	○	○	○	○	○	○	○	○	○	○	○	○	○	○	○	○	○	○	○

■ GMP 圆角精磨

目录编号	刀片尺寸	W	RC	LI	T	KCU10	KCU25	KCP10	KCP25	KCK20	K313	KC5010	KC5025	KY3500	KT315	KB1630	KB6625	KD1405	
A4R0200M02P00GMP	2	2,00	1,0	20	1,7	●	●	-	-	-	-	●	●	-	-	-	-	-	-
A4R0300M03P00GMP	3	3,00	1,5	20	2,5	●	●	-	-	-	●	●	●	-	-	-	-	-	-
A4R0400M04P00GMP	4	4,00	2,0	20	-	●	●	-	-	-	●	●	●	-	-	-	-	-	-
A4R0500M05P00GMP	5	5,00	2,5	25	4,1	●	●	-	-	-	●	●	●	-	-	-	-	-	-
A4R0600M06P00GMP	6	6,00	3,0	30	4,8	●	●	-	-	-	-	●	●	-	-	-	-	-	-
A4R0800M08P00GMP	8	8,00	4,0	30	6,4	●	●	-	-	-	-	●	●	-	-	-	-	-	-

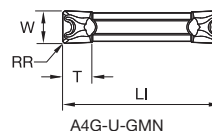
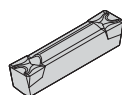

■ GMN 精密压铸

目录编号	刀片尺寸	W	RR	LI	T	KCU10	KCU25	KCP10	KCP25	KCK20	K313	KC5010	KC5025	KY3500	KT315	KB1630	KB6625	KD1405	
A4G0205M02U02GMN	2	2,05	0,2	20	2,0	●	●	-	-	-	-	●	●	-	-	-	-	-	-
A4G0255M2BU02GMN	2B	2,62	0,2	20	2,0	-	-	-	-	-	-	-	-	-	-	-	-	-	-
A4G0305M03U02GMN	3	3,05	0,2	20	3,5	●	●	●	●	-	-	●	●	-	-	-	-	-	-
A4G0305M03U04GMN	3	3,05	0,4	20	3,5	●	●	●	●	-	-	●	●	-	-	-	-	-	-
A4G0405M04U04GMN	4	4,05	0,4	20	3,4	●	●	-	-	-	-	●	●	-	-	-	-	-	-
A4G0405M04U08GMN	4	4,05	0,8	20	3,4	●	●	●	●	-	-	●	●	-	-	-	-	-	-
A4G0505M05U04GMN	5	5,05	0,4	25	4,2	●	●	●	●	-	-	●	●	-	-	-	-	-	-
A4G0505M05U08GMN	5	5,05	0,8	25	4,2	●	●	●	●	-	-	●	●	-	-	-	-	-	-
A4G0605M06U04GMN	6	6,05	0,4	30	4,9	●	●	●	●	-	-	●	●	-	-	-	-	-	-
A4G0605M06U08GMN	6	6,05	0,8	30	4,9	●	●	●	●	-	-	●	●	-	-	-	-	-	-
A4G0605M06U12GMN	6	6,05	1,2	30	4,9	-	-	-	-	-	-	●	●	-	-	-	-	-	-
A4G0805M08U08GMN	8	8,05	0,8	30	6,4	●	●	●	●	-	-	●	●	-	-	-	-	-	-
A4G0805M08U12GMN	8	8,05	1,2	30	6,4	-	●	●	●	-	-	●	●	-	-	-	-	-	-
A4G1005M10U08GMN	10	10,05	0,8	30	8,1	-	●	●	●	-	-	●	●	-	-	-	-	-	-
A4G1005M10U12GMN	10	10,05	1,2	30	8,1	-	-	-	●	-	-	●	●	-	-	-	-	-	-

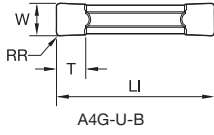
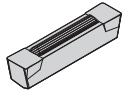

● 首选
○ 备选

■ 平板精密压铸

目录编号	刀片尺寸	W	RR	LI	T	KCU10	KCU25	KCP10	KCP25	KCK20	K313	KC5010	KC5025	KY3500	KT315	KB1630	KB5625	KD1405
A4G0305M03U02B	3	3,05	0,2	20	3,5	-	●	-	-	●	-	-	●	-	-	-	-	-
A4G0405M04U04B	4	4,05	0,4	20	3,4	-	●	-	-	●	-	-	●	-	-	-	-	-
A4G0505M05U04B	5	5,05	0,4	25	4,2	-	●	-	-	●	-	-	●	-	-	-	-	-
A4G0605M06U04B	6	6,05	0,4	30	4,9	-	●	-	-	●	-	-	●	-	-	-	-	-
A4G0805M08U08B	8	8,05	0,8	30	6,4	-	-	-	-	●	-	-	-	-	-	-	-	-
A4G1005M10U08B	10	10,05	0,8	30	8,1	-	-	-	-	●	-	-	-	-	-	-	-	-

A4™ 切槽及车削刀片 • 小直径端面切槽刀具

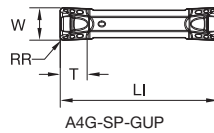
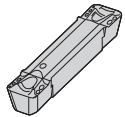

● 首选
○ 备选

■ GUP 精密压铸 • 小直径端面切槽刀具

目录编号	刀片尺寸	W	RR	LI	T	KCU10	KCU25	KCP10	KCP25	KCK20	K313	KC5010	KC5025	KY3500	KT315	KB1630	KB5625	KD1405
A4G0200M2SP02GUP	2S	2,00	0,2	20	1,9	●	●	-	-	-	-	-	-	-	-	-	-	-
A4G0300M3SP02GUP	3S	3,00	0,2	20	2,9	●	●	-	-	-	-	-	-	-	-	-	-	-
A4G0300M3SP04GUP	3S	3,00	0,4	20	2,9	●	●	-	-	-	-	-	-	-	-	-	-	-
A4G0400M4SP04GUP	4S	4,00	0,4	20	3,4	●	-	-	-	-	-	-	-	-	-	-	-	-
A4G0400M4SP08GUP	4S	4,00	0,8	20	3,4	●	-	-	-	-	-	-	-	-	-	-	-	-
A4G0500M5SP04GUP	5S	5,00	0,4	25	4,1	-	●	-	-	-	-	-	-	-	-	-	-	-
A4G0500M5SP08GUP	5S	5,00	0,8	25	4,1	●	-	-	-	-	-	-	-	-	-	-	-	-

注：A4-S 刀片在 A4 刀片的基础上减少了高度。举例而言，刀座型号为 2S 的刀柄不能使用安装座尺寸为 2 的刀片。

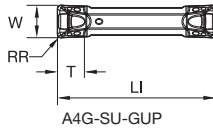
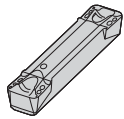

● 首选
○ 备选

■ GUP 精磨 • 小直径端面切槽刀具

目录编号	刀片尺寸	W	RR	LI	T	KCU10	KCU25	KCP10	KCP25	KCK20	K313	KC5010	KC5025	KY3500	KT315	KB1630	KB5625	KD1405	
A4G0205M2SU02GUP	2S	2,05	0,2	20	2,0	●	●	-	-	-	-	-	-	-	-	-	-	-	-
A4G0305M3SU02GUP	3S	3,05	0,2	20	3,0	●	●	-	-	-	-	-	-	-	-	-	-	-	-
A4G0305M3SU04GUP	3S	3,05	0,4	20	3,0	●	●	-	-	-	-	-	-	-	-	-	-	-	-
A4G0405M4SU04GUP	4S	4,05	0,4	20	3,4	●	●	-	-	-	-	-	-	-	-	-	-	-	-
A4G0505M5SU04GUP	5S	5,05	0,4	25	4,2	●	●	-	-	-	-	-	-	-	-	-	-	-	-
A4G0505M5SU08GUP	5S	5,05	0,8	25	4,2	-	●	-	-	-	-	-	-	-	-	-	-	-	-

注: A4-S刀片在A4刀片的基础上减少了高度。举例而言, 刀座型号为2S的刀柄不能使用安装座尺寸为2的刀片。

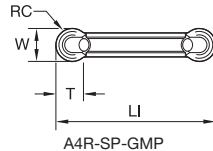
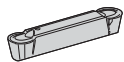

■ GMP 圆角精磨 • 小直径端面切槽刀具

目录编号	刀片尺寸	W	RC	LI	T	KCU10	KCU25	KCP10	KCP25	KCK20	K313	KC5010	KC5025	KY3500	KT315	KB1630	KB5625	KD1405	
A4R0200M2SP00GMP	2S	2,00	1,0	20	1,6	-	●	-	-	-	-	-	-	-	-	-	-	-	-
A4R0300M3SP00GMP	3S	3,00	1,5	20	2,5	-	●	-	-	-	-	-	-	-	-	-	-	-	-
A4R0500M5SP00GMP	5S	5,00	2,5	25	4,1	-	●	-	-	-	-	-	-	-	-	-	-	-	-

注: A4-S 刀片在 A4 刀片的基础上减少了高度。举例而言, 刀座型号为 2S 的刀柄不能使用安装座尺寸为 2 的刀片。

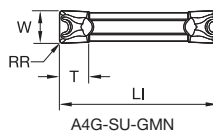
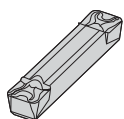

■ GMN 精密压铸 • 小直径端面切槽刀具

目录编号	刀片尺寸	W	RR	LI	T	KCU10	KCU25	KCP10	KCP25	KCK20	K313	KC5010	KC5025	KY3500	KT315	KB1630	KB5625	KD1405	
A4G0205M2SU02GMN	2S	2,05	0,2	20	2,0	●	●	-	-	-	-	-	-	-	-	-	-	-	-
A4G0305M3SU02GMN	3S	3,05	0,2	20	3,5	-	●	-	-	-	-	-	-	-	-	-	-	-	-
A4G0305M3SU04GMN	3S	3,05	0,4	20	3,5	●	●	-	-	-	-	-	-	-	-	-	-	-	-
A4G0405M4SU04GMN	4S	4,05	0,4	20	3,6	●	●	-	-	-	-	-	-	-	-	-	-	-	-
A4G0405M4SU08GMN	4S	4,05	0,8	20	3,6	-	●	-	-	-	-	-	-	-	-	-	-	-	-
A4G0505M5SU04GMN	5S	5,05	0,4	25	4,2	●	●	-	-	-	-	-	-	-	-	-	-	-	-

注: A4-S 刀片在 A4 刀片的基础上减少了高度。举例而言, 刀座型号为 2S 的刀柄不能使用安装座尺寸为 2 的刀片。

P	●	●	●	○	○	○	○	○	○	○	○	○	○	○	○	○	○	○	○
M	●	●	○	○	○	○	○	○	○	○	○	○	○	○	○	○	○	○	○
K	○	○	○	○	○	○	○	○	○	○	○	○	○	○	○	○	○	○	○
N	○	○	○	○	○	○	○	○	○	○	○	○	○	○	○	○	○	○	○
S	○	○	○	○	○	○	○	○	○	○	○	○	○	○	○	○	○	○	○
H	○	○	○	○	○	○	○	○	○	○	○	○	○	○	○	○	○	○	○

切槽及切断

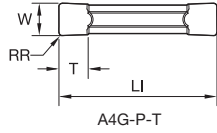
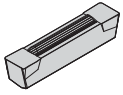

● 首选
○ 备选

P	●
M	○
K	○
N	○
S	○
H	○

■ 精密研磨平板型 • 陶瓷

目录编号	刀片尺寸	W	RR	LI	T	KY3500
A4G0300M03P04T01025	3	3,00	0,4	20	3,4	●
A4G125I03P1T0425	3	3,18	0,4	20	3,4	●
A4G0400M04P04T01025	4	4,00	0,4	20	3,4	●
A4G0500M05P08T01025	5	5,00	0,8	25	4,2	●
A4G0600M06P08T01025	6	6,00	0,8	30	4,8	●
A4G250I06P2T0425	6	6,35	0,8	30	4,9	●
A4G0800M08P08T01025	8	8,00	0,8	30	6,4	●

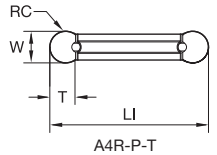
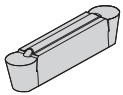

■ 平板型全圆角精密研磨 • 陶瓷

目录编号	刀片尺寸	W	RC	LI	T	KY3500
A4R0300M03P00T01025	3	3,00	1,5	20	2,4	●
A4R0500M05P00T01025	5	5,00	2,5	25	4,1	●
A4R0600M06P00T01025	6	6,00	3,0	30	4,3	●
A4R250I06P00T0425	6	6,35	3,2	30	4,8	●
A4R0800M08P00T01025	8	8,00	4,0	30	6,4	●

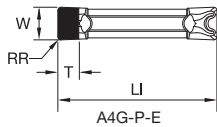
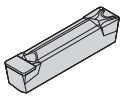

● 首选
○ 备选

P	●	●	●	○	○	○	○	○	○	○	○	○	○	○	○	○	○	○	○	○
M	○	○	○	○	○	○	○	○	○	○	○	○	○	○	○	○	○	○	○	○
K	○	○	○	○	○	○	○	○	○	○	○	○	○	○	○	○	○	○	○	○
N	○	○	○	○	○	○	○	○	○	○	○	○	○	○	○	○	○	○	○	○
S	○	○	○	○	○	○	○	○	○	○	○	○	○	○	○	○	○	○	○	○
H	○	○	○	○	○	○	○	○	○	○	○	○	○	○	○	○	○	○	○	○

■ 精密研磨平板型 • PCD

目录编号	刀片尺寸	W	RR	LI	T	KCU10	KCU25	KCP10	KCP25	KCK20	K313	KC5010	KC5025	KY3500	KT315	KB1630	KB5625	KD1405	
A4G0300M03P04E	3	3,00	0,4	20	3,0	-	-	-	-	-	-	-	-	-	-	-	-	-	●
A4G0400M04P04E	4	4,00	0,4	20	3,0	-	-	-	-	-	-	-	-	-	-	-	-	-	●
A4G0500M05P08E	5	5,00	0,8	25	3,0	-	-	-	-	-	-	-	-	-	-	-	-	-	●

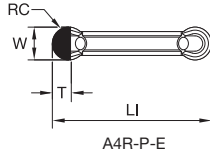
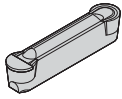

A4R-P-E

● 首选
○ 备选

P	●	●	●	○	○	○	○				
M	●	●			○	○	○				
K	○	○	○	○	○	○	○	○	○	○	○
N	●	○			○	○	○				●
S	●	●			○	○	○	○	○	○	
H	○									○	○

■ 平板圆角精磨 • PCD

目录编号	刀片尺寸	W	RC	LI	T
A4R0500M05P00E	5	5,00	2,5	25	3,0

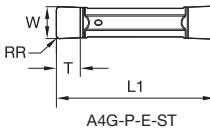
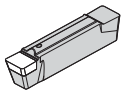

A4G-P-E-ST

■ 平板型 精磨 • PcBN

目录编号	刀片尺寸	W	RR	LI	T
A4G0300M03P04EST	3	3,00	0,4	20	3,0
A4G0500M05P08EST	5	5,00	0,8	25	3,5
A4G0600M06P08EST	6	6,00	0,8	30	4,0

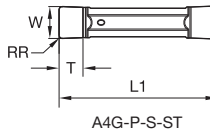
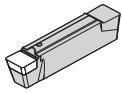

A4G-P-S-ST

■ 平板型 精磨 • T 型倒棱 • PcBN

目录编号	刀片尺寸	W	RR	LI	T
A4G0300M03P04S02025ST	3	3,00	0,4	20	3,0
A4G0400M04P04S02025ST	4	4,00	0,4	20	3,3
A4G0500M05P08S02025ST	5	5,00	0,8	25	3,5
A4G0600M06P08S02025ST	6	6,00	0,8	30	4,0

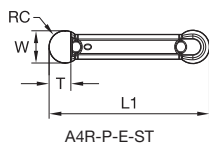
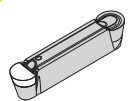

A4R-P-E-ST

● 首选
○ 备选

	P	M	K	N	S	H	KCU10	KCU25	KCP10	KCP25	KCK20	K313	KC5010	KC5025	KY3500	KT315	KB1630	KB5625	KD1405	
P	●	●	●	○	○	○	○	○	○	○	○	○	○	○	○	○	○	○	○	○
M	●	●	○	○	○	○	○	○	○	○	○	○	○	○	○	○	○	○	○	○
K	○	○	○	○	○	○	○	○	○	○	○	○	○	○	○	○	○	○	○	○
N	●	○	○	○	○	○	○	○	○	○	○	○	○	○	○	○	○	○	○	○
S	●	●	○	○	○	○	○	○	○	○	○	○	○	○	○	○	○	○	○	○
H	○	○	○	○	○	○	○	○	○	○	○	○	○	○	○	○	○	○	○	○

■ 平板圆角精磨 • PcBN

目录编号	刀片尺寸	W	RC	LI	T	KCU10	KCU25	KCP10	KCP25	KCK20	K313	KC5010	KC5025	KY3500	KT315	KB1630	KB5625	KD1405	
A4R0300M03P00EST	3	3,00	1,5	20	2,2	-	-	-	-	-	-	-	-	-	-	●	-	-	-
A4R0400M04P00EST	4	4,00	2,0	20	2,9	-	-	-	-	-	-	-	-	-	-	●	-	-	-
A4R0500M05P00EST	5	5,00	2,5	25	3,7	-	-	-	-	-	-	-	-	-	-	●	-	-	-
A4R0600M06P00EST	6	6,00	3,0	30	4,4	-	-	-	-	-	-	-	-	-	-	●	-	-	-

A4™ 切断刀片

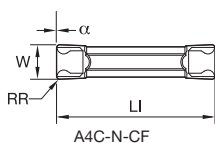
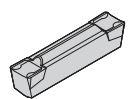

A4C-N-CF

● 首选
○ 备选

	P	M	K	N	S	H	KCU10	KCU25	KCP10	KCP25	KCK20	K313	KC5010	KC5025	KY3500	KT315	KB1630	KB5625	KD1405	
P	●	●	●	○	○	○	○	○	○	○	○	○	○	○	○	○	○	○	○	○
M	●	●	○	○	○	○	○	○	○	○	○	○	○	○	○	○	○	○	○	○
K	○	○	○	○	○	○	○	○	○	○	○	○	○	○	○	○	○	○	○	○
N	●	○	○	○	○	○	○	○	○	○	○	○	○	○	○	○	○	○	○	○
S	●	●	○	○	○	○	○	○	○	○	○	○	○	○	○	○	○	○	○	○
H	○	○	○	○	○	○	○	○	○	○	○	○	○	○	○	○	○	○	○	○

■ CF 精密压铸 • 中置

目录编号	刀片尺寸	W	RR	LI	α	KCU10	KCU25	KCP10	KCP25	KCK20	K313	KC5010	KC5025	KY3500	KT315	KB1630	KB5625	KD1405	
A4C0155N00CF01	1	1,50	0,2	16	-	-	●	-	-	-	-	-	-	-	-	-	-	-	-
A4C0205N00CF02	2	2,05	0,2	20	-	-	●	-	-	-	-	-	-	-	-	-	-	-	-
A4C0255N00CF02	2B	2,50	0,2	20	-	-	●	-	-	-	-	-	-	-	-	-	-	-	-
A4C0305N00CF02	3	3,05	0,2	20	-	-	●	-	-	-	-	-	-	-	-	-	-	-	-
A4C0405N00CF02	4	4,05	0,2	20	-	-	●	-	-	-	-	-	-	-	-	-	-	-	-

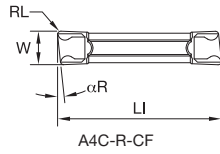
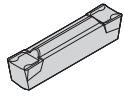

A4C-R-CF

CF 精密压铸 • 右手

目录编号	刀片尺寸	W	RL	LI	αR	KCU10	KCU25	KCP10	KCP25	KCK20	K313	KC5010	KC5025	KY3500	KT315	KB1630	KB5625	KD1405	
A4C0155R06CF01	1	1,50	0,2	16	6.0	-	-	-	-	-	-	-	●	-	-	-	-	-	-
A4C0155R10CF01	1	1,50	0,2	16	10.0	-	●	-	-	-	-	-	-	-	-	-	-	-	-
A4C0155R16CF01	1	1,50	0,2	16	16.0	-	-	-	-	-	-	-	●	-	-	-	-	-	-
A4C0205R06CF02	2	1,99	0,2	20	6.0	-	●	-	-	-	-	-	●	-	-	-	-	-	-
A4C0205R10CF02	2	1,99	0,2	20	10.0	-	●	-	-	-	-	-	-	-	-	-	-	-	-
A4C0255R06CF02	2B	2,49	0,2	20	6.0	-	-	-	-	-	-	-	●	-	-	-	-	-	-
A4C0305R06CF02	3	3,05	0,2	20	6.0	-	●	-	-	-	-	-	●	-	-	-	-	-	-
A4C0305R10CF02	3	3,05	0,2	20	10.0	-	●	-	-	-	-	-	●	-	-	-	-	-	-
A4C0405R06CF02	4	4,05	0,2	20	6.0	-	●	-	-	-	-	-	●	-	-	-	-	-	-
A4C0405R10CF02	4	4,05	0,2	20	10.0	-	●	-	-	-	-	-	●	-	-	-	-	-	-

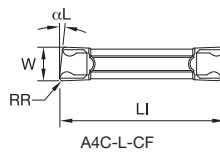
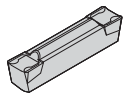

A4C-L-CF

CF 精密压铸 • 左手

目录编号	刀片尺寸	W	RR	LI	αL	KCU10	KCU25	KCP10	KCP25	KCK20	K313	KC5010	KC5025	KY3500	KT315	KB1630	KB5625	KD1405	
A4C0155L06CF01	1	1,50	0,2	16	6.0	-	-	-	-	-	-	-	●	-	-	-	-	-	-
A4C0205L06CF02	2	1,99	0,2	20	6.0	-	●	-	-	-	-	-	-	-	-	-	-	-	-
A4C0205L10CF02	2	1,99	0,2	20	10.0	-	-	-	-	-	-	-	●	-	-	-	-	-	-
A4C0305L06CF02	3	3,05	0,2	20	6.0	-	●	-	-	-	-	-	●	-	-	-	-	-	-
A4C0305L10CF02	3	3,05	0,2	20	10.0	-	●	-	-	-	-	-	●	-	-	-	-	-	-
A4C0405L06CF02	4	4,05	0,2	20	6.0	-	●	-	-	-	-	-	●	-	-	-	-	-	-
A4C0405L10CF02	4	4,05	0,2	20	10.0	-	●	-	-	-	-	-	●	-	-	-	-	-	-

 ● 首选
 ○ 备选

P	●	●	●	●	○	○	○	○	○	○	○	○	○	○	○	○	○	○	○
M	●	●	○	○	○	○	○	○	○	○	○	○	○	○	○	○	○	○	○
K	○	○	○	○	○	○	○	○	○	○	○	○	○	○	○	○	○	○	○
N	○	○	○	○	○	○	○	○	○	○	○	○	○	○	○	○	○	○	○
S	○	○	○	○	○	○	○	○	○	○	○	○	○	○	○	○	○	○	○
H	○	○	○	○	○	○	○	○	○	○	○	○	○	○	○	○	○	○	○

切槽及切断

如何使用目录编号?

产品目录中的每一个字符都表示产品的一个具体特征。利用下面的栏框以及对应的图形，可以容易地找到适用的刀具参数值。



A4SMR2020M0214

A4

刀柄系统

A4 =
切槽与车削

S

刀具类型

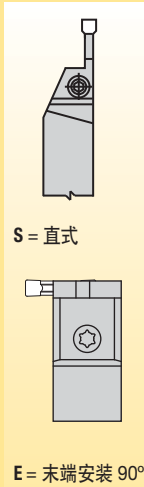

M

刀架类型

M =
用于特定切槽宽度和垂直间隙角的大型刀架，可用于多种直径工件的加工
E =
没有用于端面切槽的钢刀架
C =
增强型刀架

R

刀具方向

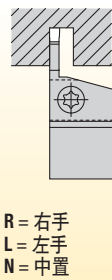

2020M

刀杆尺寸

公制:
高 × 宽 (毫米)，字母表示刀具长度 (ISO标准)
公制刀架长度 (毫米)
K = 125
M = 150
P = 170

02

安装座尺寸

02
03
04
05
06
08
10

14

最大切槽深度

单位 mm

这份指南使用非常方便、可以快速找到客户需要查找的产品。

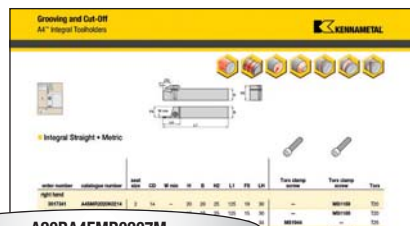

A20RA4EMR0207M

A

带内冷的
钢镗杆

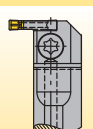

20

镗杆直径

R

镗杆长度

A4

A4™ 切槽
及车削
刀具

E

刀具类型

M

刀架类型

R

刀具方向

02

刀片安装
座尺寸

07

切槽深度
(毫米)

M

刀具系统

M = 公制

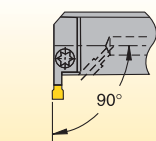

E = 末端安装 (90°)

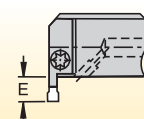

mm
7mm
10mm
12mm
16mm

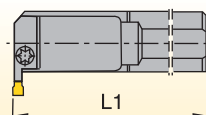

公制镗杆:
R = 200mm
S = 150mm
T = 300mm

刀窝安装座尺寸	切削宽度 (毫米)
02	2,00-2,62
2B	2,39-2,62
03	3,0-3,05
04	4,0-4,05
05	5,0-5,05
06	6,0-6,05
08	8,0-8,05
10	10,0-10,05

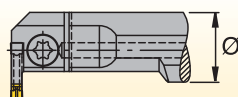

公制镗杆:
镗杆直径 (毫米)

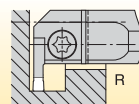

R = 右手

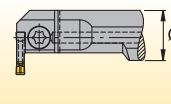

L = 左手

M = 大型刀架

如何使用目录编号？

产品目录中的每一个字符都表示产品的一个具体特征。利用下面的栏框以及对应的图形，可以容易地找到适用的刀具参数值。



KGM	S	L	2525M	50	C
产品系列名	刀具类型	方向	刀杆尺寸	刀板尺寸	冷却剂
模块化切槽刀柄	S = 直型安装座 E = 端部安装座 (90°)	L = 左手 R = 右手	公制 = 高 x 宽 (毫米), 字母表示刀具长度 (ISO 标准)	50 65	C = 具有内冷性能

切槽刀具和 Beyond™ 刀片可用于 浅切槽和车削加工

Top Notch™



Top Notch Grooving 切槽刀具是一款成熟的，高效率产品。Top Notch 刀具具有稳定的加工性能，精确的转位性能，卓越的夹持性能，出色的表面精加工性能和超长的刀具寿命。

特点及优势

- Beyond PVD 涂层材质可用于多种工件材料的切削加工。
- 即使在加工条件最为苛刻的切削加工中，具有良好刚性的夹具系统仍然可以稳固地锁定刀片。
- 多功能的设计方案，单个刀具系统既可进行外圆、内圆、切槽、端面切槽、背车、根切加工，甚至还可进行螺纹加工。
- 具有切屑控制性能的刀片可在切槽加工中顺利排出切屑，并且在多向车削加工中具有更好的切屑控制性能。

联系肯纳金属授权经销商，或是登录
kennametal.com，了解更多的产品优势。



kennametal.com

关于PDF内容涉及《广告法》违禁词、极限词用语作废声明
本PDF文字、图片中涉及《广告法》中违禁词、极限词等词语的，在此申明一律作废，不作为产品介绍的依据。谢谢配合。

如何使用目录编号？

产品目录中的每一个字符都表示产品的一个具体特征。利用下面的栏框以及对应的图形，可以容易地找到适用的刀具参数值。

Grooving and Cut-Off
A4™ Integral Toolholders

Integral Face Grooving • Outboard • Metric

Order number	Catalogue number	Head size	D min	D max	CD	W min	FR	Height
300-017	A4M50R0414B048-072	2	38	45	12	2	10.00	30
300-018	A4M50R0414B048-072	3	42	48	12	2	10.00	30
300-019	A4M50R0414B048-072	2	50	58	12	2	10.00	30
300-020	A4M50R0414B048-072	3	55	62	12	2	10.00	30

A4M50R0414B048-072

A4M

产品系列名

A4 模块化刀板

50

模块刀柄尺寸

50
65

R

刀具方向

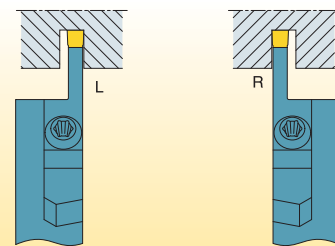

这份指南使用非常方便，可以快速找到客户需要查找的产品。

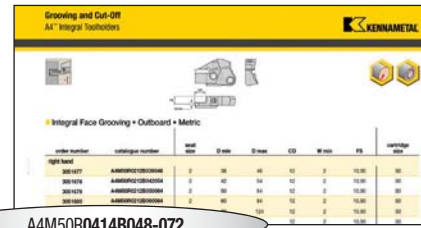

A4M50R0414B048-072

04

安装座尺寸

刀窝安装座尺寸	切削宽度 mm
02	2,00-2,62
2B	2,39-2,62
03	3,0-3,05
04	4,0-4,05
05	5,0-5,05
06	6,0-6,05
08	8,0-8,05
10	10,0-10,05

14

最大切槽深度



mm
14mm
19mm
20mm
26mm

B

刀具类型



M = 用于特定切槽宽度和垂直间隙角的大型刀架，可用于多种直径工件的加工



A = 内侧端面切槽刀柄



B = 外侧端面切槽刀柄

048-072

端面切槽直径范围

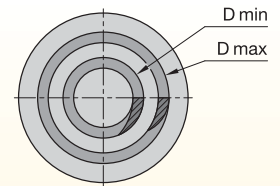

端面切槽外部直径的最小值和最大值 999 = 没有限制的 D 最大值

如何使用目录编号？

产品目录中的每一个字符都表示产品的一个具体特征。利用下面的栏框以及对应的图形，可以容易地找到适用的刀具参数值。

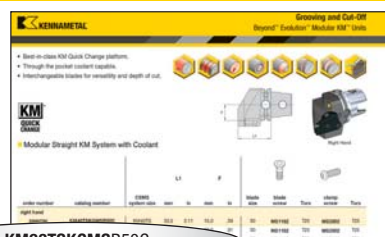

KM63TSKGMRS50C

KM

KM™ 快速换刀装置

KM
KM4X™
PSC

63

刀柄规格

40 = 40mm
50 = 50mm
63 = 63mm
80 = 80mm
100 = 100mm

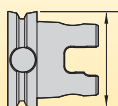

TS

特点

TS
XMZ

KGM

刀片夹持方法

KGM

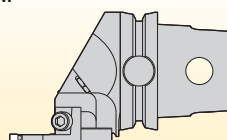

模块化切槽刀具

S

刀片位置

E = 端部安装座

S = 侧面安装

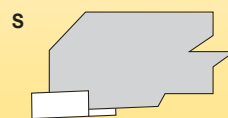
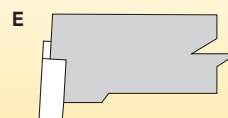

这份指南使用非常方便，可以快速找到客户需要查找的产品。

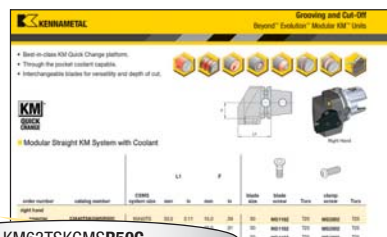

KM63TSKGMRS50C

R

刀具方向

R = 右手
L = 左手

端部安装座

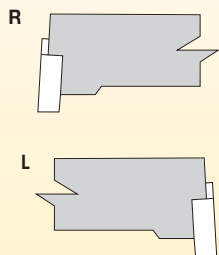

侧面安装座

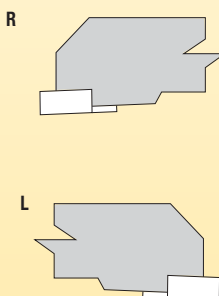

50

刀板尺寸

50
60

C

冷却方式

C = 刀座具备内冷性能

特殊功能

Y = Mazak®
INTEGREX®

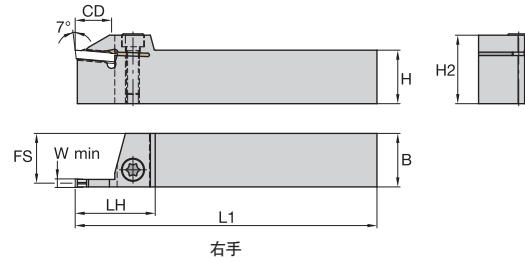
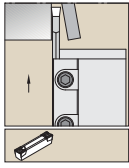

■ 整体式直型 • 公制



订货号	目录编号	刀片尺寸	CD	W min	H	B	H2	L1	FS	LH	夹紧螺钉	夹紧螺钉	Torx
右手													
3017341	A4SMR2020K0214	2	14	—	20	20	25	125	19	30	—	MS1160	T20
3017342	A4SMR1616K0214	2	14	2	16	16	25	125	15	30	—	MS1160	T20
2974425	A4SMR2020K0217	2	17	2	20	20	31	125	19	34	MS1944	—	T25
3017340	A4SMR2525M0214	2	14	2	25	25	30	150	24	30	—	MS1160	T20
3017339	A4SMR2525M0217	2	17	2	25	25	31	150	24	34	MS1944	—	T25
1949633	A4SMR1616K0314	3	14	3	16	16	27	125	15	35	MS2091	—	T25
2503557	A4SMR2016K0317	3	17	3	20	16	32	125	15	37	MS1970	—	T30
1949635	A4SMR2020K0314	3	14	3	20	20	27	125	19	35	MS1595	—	T30
2503551	A4SMR2020K0317	3	17	3	20	20	32	125	19	37	MS1970	—	T30
1949637	A4SMR2525M0317	3	17	3	25	25	32	150	24	37	MS1970	—	T30
2503559	A4SMR2016K0417	4	17	4	20	16	32	125	14	37	MS1970	—	T30
1949639	A4SMR2020K0414	4	14	4	20	20	27	125	18	35	MS1595	—	T30
2503553	A4SMR2020K0417	4	17	4	20	20	32	125	18	37	MS1970	—	T30
1949641	A4SMR2525M0417	4	17	4	25	25	32	150	23	37	MS1970	—	T30
1949643	A4SMR3225P0417	4	17	4	32	25	40	170	23	37	MS1970	—	T30
1949645	A4SMR2020K0519	5	19	5	20	20	28	125	18	40	MS1595	—	T30
1949647	A4SMR2525M0520	5	20	5	25	25	33	150	23	40	MS1970	—	T30
1949649	A4SMR3225P0522	5	22	5	32	25	40	170	23	42	MS1970	—	T30
2503555	A4SMR2020K0620	6	20	6	20	20	33	125	17	40	MS1970	—	T30
2245484	A4SMR2525M0620	6	20	6	25	25	33	150	22	40	MS1970	—	T30
2263089	A4SMR3225P0626	6	26	6	32	25	40	170	22	45	MS1970	—	T30
2245485	A4SMR2525M0820	8	20	8	25	25	34	150	21	43	MS1490	—	T45
2263091	A4SMR3225P0826	8	26	8	32	25	41	170	21	47	MS1490	—	T45
2263173	A4SMR3225P1026	10	26	10	32	25	41	170	21	47	MS1490	—	T45

(续)

(整体式直型 • 公制 — 续)



订货号	目录编号	刀片尺寸	CD	W min	H	B	H2	L1	FS	LH	夹紧螺钉	夹紧螺钉	Torx
左手													
3017336	A4SML2020K0214	2	14	—	20	20	25	125	19	30	—	MS1160	T20
3017338	A4SML1616K0214	2	14	2	16	16	25	125	15	30	—	MS1160	T20
3017337	A4SML2020K0217	2	17	2	20	20	31	125	19	34	MS1944	—	T25
3017335	A4SML2525M0214	2	14	2	25	25	30	150	24	30	—	MS1160	T20
3017334	A4SML2525M0217	2	17	2	25	25	31	150	24	34	MS1944	—	T25
1949634	A4SML1616K0314	3	14	3	16	16	27	125	15	35	MS2091	—	T25
2503556	A4SML2016K0317	3	17	3	20	16	32	125	15	37	MS1970	—	T30
1949636	A4SML2020K0314	3	14	3	20	20	27	125	19	35	MS1595	—	T30
2503550	A4SML2020K0317	3	17	3	20	20	32	125	19	37	MS1970	—	T30
1949638	A4SML2525M0317	3	17	3	25	25	32	150	24	37	MS1970	—	T30
1949640	A4SML2020K0414	4	14	4	20	20	27	125	18	35	MS1595	—	T30
2503552	A4SML2020K0417	4	17	4	20	20	32	125	18	37	MS1970	—	T30
1949642	A4SML2525M0417	4	17	4	25	25	32	150	23	37	MS1970	—	T30
1949644	A4SML3225P0417	4	17	4	32	25	40	170	23	37	MS1970	—	T30
1949646	A4SML2020K0519	5	19	5	20	20	28	125	18	40	MS1595	—	T30
1949648	A4SML2525M0520	5	20	5	25	25	33	150	23	40	MS1970	—	T30
1949650	A4SML3225P0522	5	22	5	32	25	40	170	23	42	MS1970	—	T30
2503554	A4SML2020K0620	6	20	6	20	20	33	125	17	40	MS1970	—	T30
2245486	A4SML2525M0620	6	20	6	25	25	33	150	22	40	MS1970	—	T30
2263090	A4SML3225P0626	6	26	6	32	25	40	170	22	45	MS1970	—	T30
2245487	A4SML2525M0820	8	20	8	25	25	34	150	21	43	MS1490	—	T45
2263092	A4SML3225P0826	8	26	8	32	25	41	170	21	47	MS1490	—	T45
2263174	A4SML3225P1026	10	26	10	32	25	41	170	21	47	MS1490	—	T45

切槽及切断

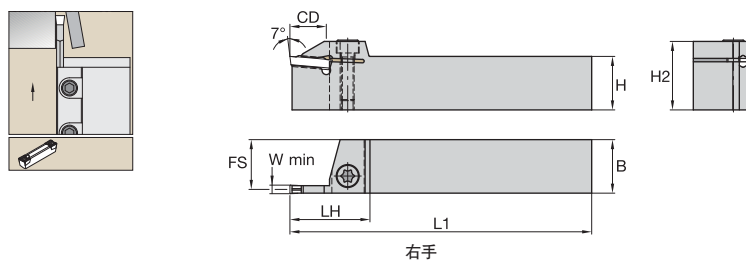

■ 整体式直型 • 短悬伸刀柄 • 公制

订货号	目录编号	刀片尺寸	CD	W min	H	B	H2	L1	FS	LH	夹紧螺钉	夹紧螺钉	Torx
右手													
3854265	A4SMR2020K0208	2	8	2	20	20	24	125	19	26	—	MS1160	T20
3854267	A4SMR2020K0308	3	8	3	20	20	27	125	19	28	MS1595	—	T30
3854269	A4SMR2020K0408	4	8	4	20	20	27	125	18	28	MS1595	—	T30
3854271	A4SMR2525M0510	5	10	5	25	25	33	150	23	32	MS1970	—	T30
3854273	A4SMR2525M0610	6	10	6	25	25	33	150	22	37	MS1970	—	T30
左手													
3854266	A4SML2020K0208	2	8	2	20	20	24	125	19	26	—	MS1160	T20
3854268	A4SML2020K0308	3	8	3	20	20	27	125	19	28	MS1595	—	T30
3854270	A4SML2020K0408	4	8	4	20	20	27	125	18	28	MS1595	—	T30
3854272	A4SML2525M0510	5	10	5	25	25	33	150	23	32	MS1970	—	T30
3854274	A4SML2525M0610	6	10	6	25	25	33	150	22	37	MS1970	—	T30

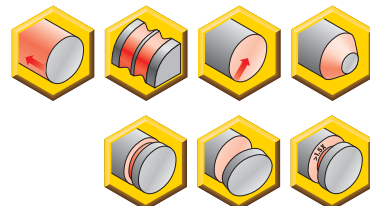
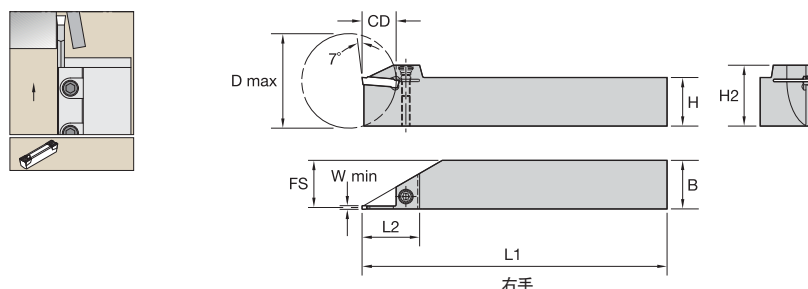

■ 整体式直型顶部夹持装置 • 公制

订货号	目录编号	刀片尺寸	D max	CD	W min	H	B	H2	L1	FS	LH	夹紧螺钉	夹紧螺钉	螺钉扳手
右手														
2982224	A4SCR1010K0113	1	27	13,500	1,50	10	10	21	125	9,40	25	MS1156	—	T15
2978378	A4SCR1212K0113	1	27	13,500	1,50	12	12	21	125	11,40	25	MS1156	—	T15
2982223	A4SCR1616K0113	1	27	13,500	1,50	16	16	21	125	15,40	25	MS1156	—	T15
2982172	A4SCR2020K0113	1	27	13,500	1,50	20	20	25	125	19,40	25	MS1156	—	T15
4169745	A4SCR1212K0214	2	28	14,000	2,00	12	12	21	125	11,17	28	MS1160	—	T20
4169746	A4SCR1616K0217	2	34	17,000	2,00	16	16	26	125	15,20	31	—	MS1944	T25
4169747	A4SCR1212K0314	3	28	14,000	3,00	12	12	23	125	10,72	30	—	MS2091	25 IP
4169748	A4SCR1616K0317	3	34	17,000	3,00	16	16	27	125	14,72	33	—	MS2091	25 IP
左手														
2982170	A4SCL1212K0113	1	27	13,500	1,50	12	12	21	125	11,40	25	MS1156	—	T15
2982169	A4SCL1616K0113	1	27	13,500	1,50	16	16	21	125	15,40	25	MS1156	—	T15
2982168	A4SCL2020K0113	1	27	13,500	1,50	20	20	25	125	19,40	25	MS1156	—	T15
4169749	A4SCL1212K0214	2	28	14,000	2,00	12	12	21	125	11,17	28	MS1160	—	T20
4169750	A4SCL1616K0217	2	34	17,000	2,00	16	16	26	125	15,20	31	—	MS1944	T25
4169752	A4SCL1616K0317	3	34	17,000	3,00	16	16	27	125	14,72	33	—	MS2091	25 IP

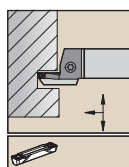

右手刀杆见图。

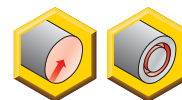
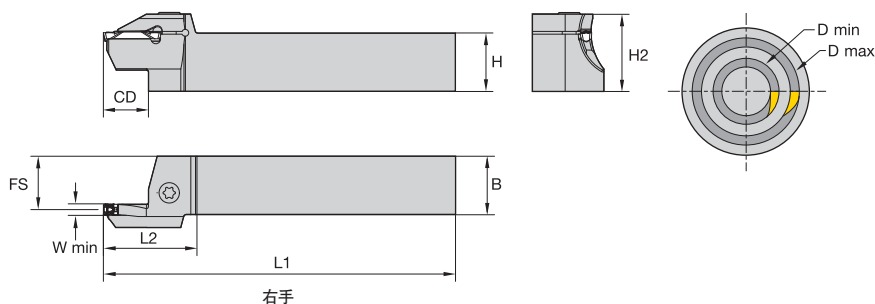

切槽及切断

■ 整体式端面切槽刀具 • 外侧 • 公制



订货号	目录编号	刀片尺寸	CD	D min	D max	W min	H	B	H2	L1	FS	LH	夹紧螺钉	Torx
右手														
3865920	A4SBR2020K2S12016020	2S	12	16	20	2,00	20	20	25	125	19,20	28	—	T20
3865921	A4SBR2020K2S12020025	2S	12	20	25	2,00	20	20	25	125	19,20	28	—	T20
3865922	A4SBR2020K2S12025036	2S	12	25	36	2,00	20	20	25	125	19,20	28	—	T20
3865923	A4SBR2020K3S14020025	3S	14	20	25	3,00	20	20	28	125	18,70	35	MS1595	T30
3865924	A4SBR2020K3S14025036	3S	14	25	36	3,00	20	20	28	125	18,70	35	MS1595	T30
3865926	A4SBR2020K4S14035048	4S	14	35	48	4,00	20	20	28	125	18,20	35	MS1595	T30
3865927	A4SBR2525M5S19028038	5S	19	28	38	5,00	25	25	33	150	22,70	40	MS1970	T30
3865928	A4SBR2525M5S19038058	5S	19	38	58	5,00	25	25	33	150	22,70	40	MS1970	T30
左手														
3865929	A4SBL2020K2S12016020	2S	12	16	20	2,00	20	20	25	125	19,20	28	—	T20
3865931	A4SBL2020K2S12025036	2S	12	25	36	2,00	20	20	25	125	19,20	28	—	T20
3865932	A4SBL2020K3S14020025	3S	14	20	25	3,00	20	20	28	125	18,70	35	MS1595	T30
3865934	A4SBL2020K4S14025035	4S	14	25	35	4,00	20	20	28	125	18,20	35	MS1595	T30
3865937	A4SBL2525M5S19038058	5S	19	38	58	5,00	25	25	33	150	22,70	40	MS1970	T30

NOVO 专注提高生产率

专业 细致 高效



尽可能提高生产率和经济效益是您的最终目标。为您的团队增配 NOVO™ 系统，可以助您实现这个目标。NOVO 拥有功能强大的数字工具，将工艺设计、库存管理、产品采购、工件成本管理、以及生产率优化等功能结合在一起。

应用 NOVO 系统，您可以在正确的时间，为自己的机床设备选择正确的刀具。从而可以完美地完成整个工艺过程，缩短加工周期，提高单班加工效率。

kenametal.com/novo



01

THE DIGITAL SOURCE FOR DELIVERING
SMART MACHINING SOLUTIONS

kenametal.com/novo

NOVOTM

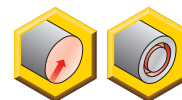
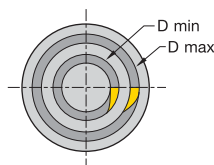
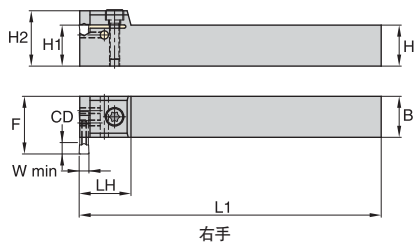
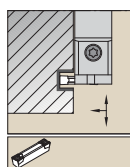

■ 整体式端面切槽刀具 • 末端安装 • 双向 • 公制

订货号	目录编号	刀片尺寸	CD	W min	D min	H1	B	H2	L1	F	LH	夹紧螺钉	Torx	六角安装螺钉	六角 (mm)
2414136	A4ENN2020K0305	3	5	3,00	70	20	20	27	125,0	25,4	25	MS2091	T25	MS2090	1.5 mm
2414137	A4ENN2525M0305	3	5	3,00	70	25	25	32	150,0	30,4	25	MS2091	T25	MS2090	1.5 mm
1949651	A4ENN2020K0407	4	7	4,00	90	20	20	27	125,0	27,9	25	MS2091	T25	MS2090	1.5 mm
1949652	A4ENN2525M0407	4	7	4,00	90	25	25	32	150,0	33,1	25	MS2091	T25	MS2090	1.5 mm
1949654	A4ENN2525M0509	5	9	5,00	120	25	25	33	150,0	35,1	34	MS1970	T30	193.297	1.5 mm
2503543	A4ENN2020K0611	6	11	6,00	120	20	20	28	125,0	35,4	34	MS1595	T30	193.297	2 mm
2503544	A4ENN2525M0611	6	11	6,00	120	25	25	33	150,0	38,9	34	MS1970	T30	193.297	2 mm
2503545	A4ENN3232P0611	6	11	6,00	120	32	32	40	170,0	43,4	34	MS1970	T30	193.297	2 mm

注: D min用于端面切槽加工应用。
A4EN 型刀柄在端面切槽加工中不使用钢支架。切削进给率推荐值应当降低25-30%。
夹板螺钉推荐力矩为50-70 in. lbs. (6-8 Nm)。
提供的最小切削宽度仅为参考; 参考刀片目录了解实际宽度。刀片安装座尺寸应当与刀柄安装座尺寸相匹配。

A4EN 刀片安装座

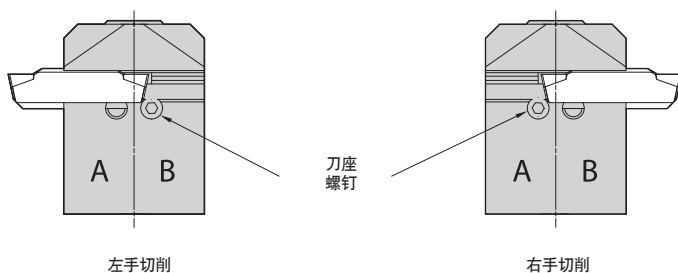

A4EN型刀柄可用于左手和右手加工应用。在左手切削加工中, 安装座螺钉的位置为B; 在右手切削加工中, 安装座螺钉的位置为A。

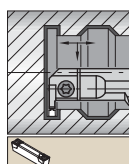
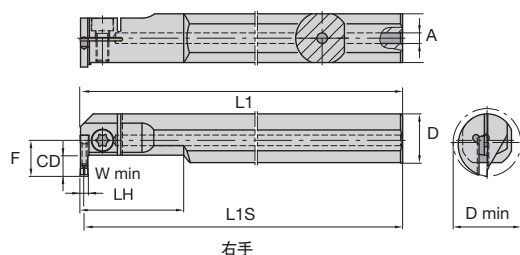
 带内冷功能的
 钢质刀柄

右手



■ 钢镗杆 • 公制



订货号	目录编号	刀片尺寸	CD	W min	D	D min	L1	F	L1S	A	夹紧螺钉	螺钉扳手
右手												
2979223	A20RA4EMR0207M	2	7,00	2,00	20	25	200	13	199,0	4,00	MS2089	25 IP
2979225	A25RA4EMR0210M	2	10,00	2,00	25	32	200	17	199,0	5,00	MS2089	25 IP
1949655	A20RA4EMR0307M	3	7,00	3,00	20	25	200	13	198,5	4,00	MS2089	25 IP
1949657	A25RA4EMR0310M	3	10,00	3,00	25	32	200	17	198,5	5,00	MS1595	T30
1949659	A32SA4EMR0312M	3	12,00	3,00	32	40	250	22	248,5	6,00	MS1595	T30
1949661	A20RA4EMR0407M	4	7,00	4,00	20	25	200	13	198,0	4,00	MS2089	25 IP
1949663	A25RA4EMR0410M	4	10,00	4,00	25	32	200	17	198,0	5,00	MS1595	T30
1949665	A32SA4EMR0412M	4	12,00	4,00	32	40	250	22	248,0	6,00	MS1595	T30
1949667	A40TA4EMR0416M	4	16,00	4,00	40	52	300	30	298,0	6,00	MS1970	T30
1949669	A32SA4EMR0516M	5	16,00	5,00	32	44	250	26	247,5	6,00	MS1595	T30
1949671	A40TA4EMR0516M	5	16,00	5,00	40	52	300	30	297,5	6,00	MS1970	T30
2263197	A40TA4EMR0616M	6	16,00	6,00	40	52	300	30	297,0	6,00	MS1970	T30
左手												
2979192	A20RA4EML0207M	2	7,00	2,00	20	25	200	13	199,0	4,00	MS2089	25 IP
2979224	A25RA4EML0210M	2	10,00	2,00	25	32	200	17	199,0	5,00	MS2089	25 IP
1949656	A20RA4EML0307M	3	7,00	3,00	20	25	200	13	198,5	4,00	MS2089	25 IP
1949658	A25RA4EML0310M	3	10,00	3,00	25	32	200	17	198,5	5,00	MS1595	T30
1949660	A32SA4EML0312M	3	12,00	3,00	32	40	250	22	248,5	6,00	MS1595	T30
1949662	A20RA4EML0407M	4	7,00	4,00	20	25	200	13	198,0	4,00	MS2089	25 IP
1949664	A25RA4EML0410M	4	10,00	4,00	25	32	200	17	198,0	5,00	MS1595	T30
1949666	A32SA4EML0412M	4	12,00	4,00	32	40	250	22	248,0	6,00	MS1595	T30
1949668	A40TA4EML0416M	4	16,00	4,00	40	52	300	30	298,0	6,00	MS1970	T30
1949670	A32SA4EML0516M	5	16,00	5,00	32	44	250	26	247,5	6,00	MS1595	T30
1949672	A40TA4EML0516M	5	16,00	5,00	40	52	300	30	297,5	6,00	MS1970	T30
2263198	A40TA4EML0616M	6	16,00	6,00	40	52	300	30	297,0	6,00	MS1970	T30



切槽及切断

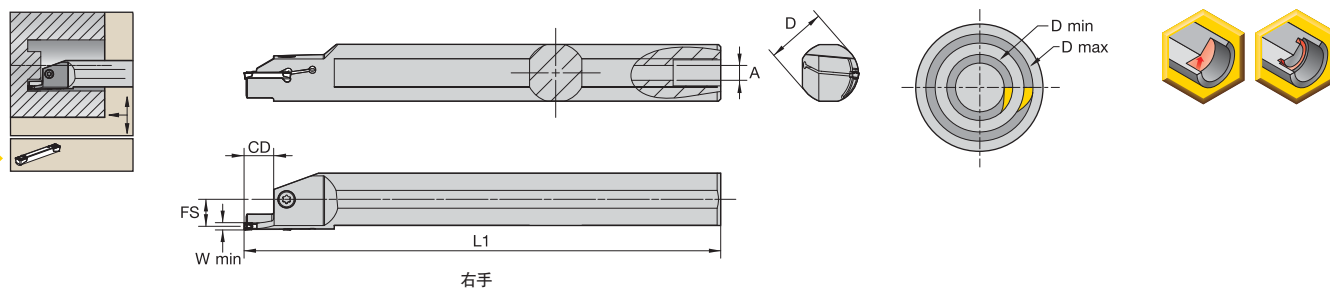

■ 钢质端面切槽镗杆 • 公制



订货号	目录编号	刀片尺寸	CD	D min	D max	W min	D	L1	FS	A	夹紧螺钉	螺钉扳手
右手												
3871038	A16RA4SAR2S12M017021	2S	12,00	17	21	2,00	16	201	7	4,00	MS1160	T20
3871039	A20RA4SAR2S12M021026	2S	12,00	21	23	2,00	20	201	9	4,00	MS1160	T20
3871040	A25RA4SAR2S12M026036	2S	12,00	26	36	2,00	25	201	12	6,35	MS1160	T20
3871041	A20RA4SAR3S14M021026	3S	14,00	21	26	3,00	20	201	9	4,00	MS1160	T20
3871042	A25RA4SAR3S14M026036	3S	14,00	26	36	3,00	25	201	11	6,35	MS1160	T20
左手												
3871033	A16RA4SAL2S12M017021	2S	12,00	17	21	2,00	16	201	7	4,00	MS1160	T20
3871034	A20RA4SAL2S12M021026	2S	12,00	21	26	2,00	20	201	9	4,00	MS1160	T20
3871035	A25RA4SAL2S12M026036	2S	12,00	26	36	2,00	25	201	12	6,35	MS1160	T20
3871037	A25RA4SAL3S14M026036	3S	14,00	26	36	3,00	25	201	11	6,35	MS1160	T20

Fix-Perfect™ 精磨刀片有着更加卓越的性能！

Fix-Perfect™

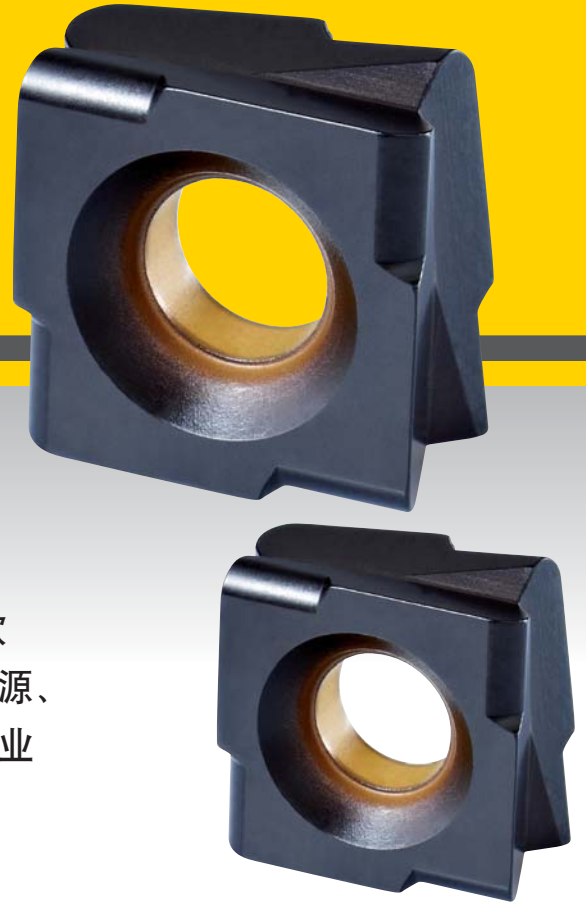

在钢材料、铸铁、以及不锈钢工件的加工中，该系列的精密研磨刀片具有精确的转位性能和理想的切屑流。Fix-Perfect Beyond™ 刀片是一款理想的刀具产品，可以满足包括流体动力、能源、汽车、重型设备、以及通用加工在内的多个行业内的机械加工需求。

联系肯纳金属授权经销商，或是登录 kennametal.com，了解更多的产品优势。



kennametal.com

关于PDF内容涉及《广告法》违禁词、极限词用语作废声明
本PDF文字、图片中涉及《广告法》中违禁词、极限词等词语的，在此申明一律作废，不作为产品介绍的依据。谢谢配合。

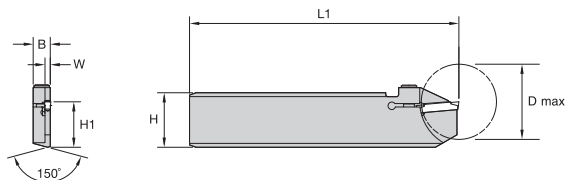
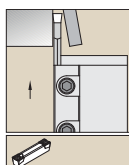

右手

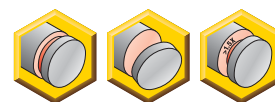

■ 单头切断刀板 • 公制

订货号	目录编号	刀片尺寸	H	W	H1	L1	B	D max	夹紧螺钉	Torx
右手										
3967127	A4BHCL26K0317R	3	26	3,0	21,4	125	7,95	35	MS1571	T20
3967124	A4BHCL32K0317R	3	32	3,0	25,0	125	7,95	35	MS1571	T20
3967117	A4BHCR32K0217R	2	32	2,0	25,0	125	7,95	35	MS1571	T20
左手										
3967136	A4BHCL32K0217L	2	32	2,0	25,0	125	7,95	35	MS1571	T20
3967137	A4BHCL32K0317L	3	32	3,0	25,0	125	7,95	35	MS1571	T20
3967134	A4BHCR26K0317L	3	26	3,0	21,4	125	7,95	35	MS1571	T20



注: 只能使用安装面型号为1的刀片。
装配扳手 170.137 和 170.130 需要单独订购。

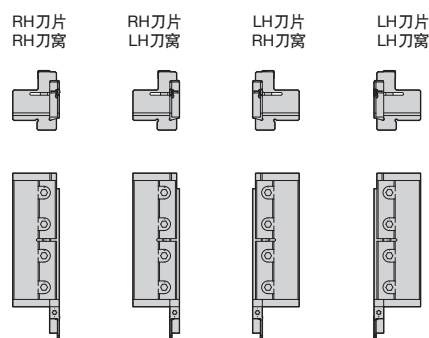

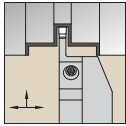

右手刀杆见图。

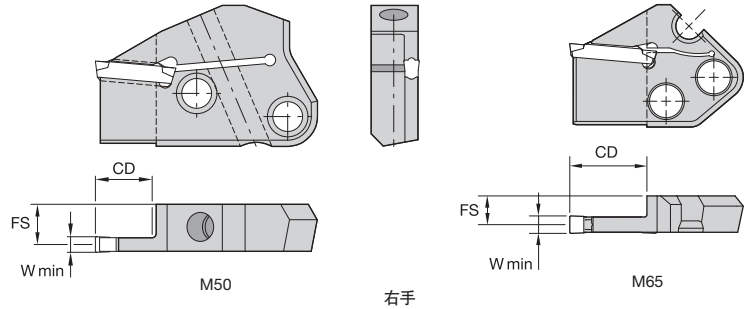

切槽及切断

■ 模块化刀柄-有冷却孔

订货号	目录编号	刀片尺寸	CD	FS	刀片尺寸
右手					
6401815	A4M50R0314MC	3	14,0	10,42	50
6401817	A4M50R0414MC	4	14,0	9,92	50
6401819	A4M50R0519MC	5	19,0	9,42	50
6401834	A4M65R0620MC	6	20,0	9,88	65
6401838	A4M65R0820MC	8	20,0	9,00	65
6401852	A4M65R1020MC	10	20,0	8,35	65
6401831	A4M65R0522MC	5	22,0	10,28	65
6401835	A4M65R0626MC	6	26,0	9,88	65
6401839	A4M65R0826MC	8	26,0	9,00	65
6401853	A4M65R1026MC	10	26,0	8,35	65
左手					
6401814	A4M50L0314MC	3	14,0	10,42	50
6401816	A4M50L0414MC	4	14,0	9,92	50
6401818	A4M50L0519MC	5	19,0	9,43	50
6401832	A4M65L0620MC	6	20,0	9,88	65
6401836	A4M65L0820MC	8	20,0	9,00	65
6401840	A4M65L1020MC	10	20,0	8,35	65
6401820	A4M65L0522MC	5	22,0	10,28	65
6401833	A4M65L0626MC	6	26,0	9,88	65
6401837	A4M65L0826MC	8	26,0	9,00	65
6401851	A4M65L1026MC	10	26,0	8,35	65

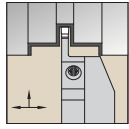

右手刀杆见图。



切槽及切断

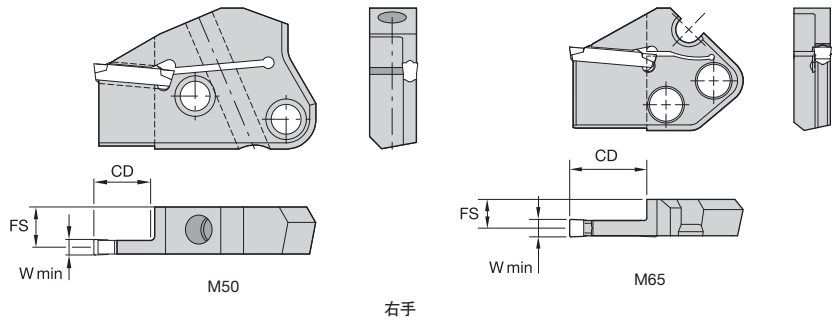

■ 模块化直型刀板

订货号	目录编号	刀片尺寸	W min	CD	FS	刀片尺寸
右手						
3051624	A4M50R0214M	2	2,00	14,0	10,87	50
1989348	A4M50R0314M	3	3,00	14,0	10,43	50
1989350	A4M50R0414M	4	4,00	14,0	9,93	50
1989352	A4M50R0519M	5	5,00	19,0	9,43	50
3557114	A4M65R0620M	6	6,00	20,0	9,88	65
3557116	A4M65R0626M	6	6,00	26,0	9,88	65
3557120	A4M65R0826M	8	8,00	26,0	9,00	65
3557124	A4M65R1026M	10	10,00	26,0	8,35	65
左手						
3022625	A4M50L0214M	2	2,00	14,0	10,87	50
1989347	A4M50L0314M	3	3,00	14,0	10,43	50
1989349	A4M50L0414M	4	4,00	14,0	9,93	50
3051623	A4M50L2B14M	2B	2,50	14,0	10,70	50
1989351	A4M50L0519M	5	5,00	19,0	9,43	50
3557115	A4M65L0620M	6	6,00	20,0	9,88	65
3557119	A4M65L0820M	8	8,00	20,0	9,00	65
3557123	A4M65L1020M	10	10,00	20,0	8,35	65
3557117	A4M65L0626M	6	6,00	26,0	9,88	65
3557121	A4M65L0826M	8	8,00	26,0	9,00	65
3557125	A4M65L1026M	10	10,00	26,0	8,35	65

注: 安装座规格为 2B 的产品只能使用 2B 刀片。安装座规格为 2 的产品只能使用 2 或 2B 刀片。

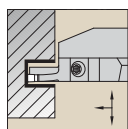

右手

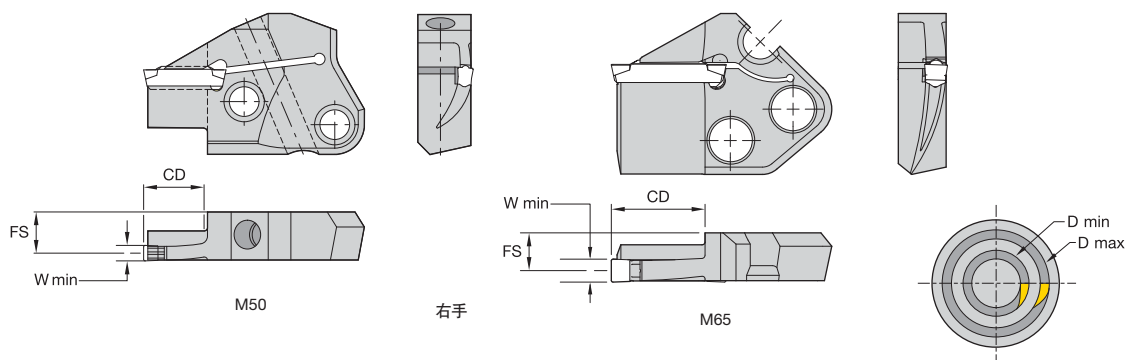
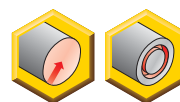

切槽及切断

■ 模块化端面切槽刀板 • 内侧

订货号	目录编号	刀片尺寸	D min	D max	刀夹尺寸
右手					
3051670	A4M50R0212A036046	2	36	46	50
3051671	A4M50R0212A042054	2	42	54	50
3051672	A4M50R0212A050064	2	50	64	50
3051673	A4M50R0212A060084	2	60	84	50
3051674	A4M50R0212A080124	2	80	124	50
3051675	A4M50R0212A120254	2	120	254	50
3051676	A4M50R0212A250999	2	250	—	50
2542517	A4M50R0314A036048	3	36	48	50
2542518	A4M50R0314A042058	3	42	58	50
2542519	A4M50R0314A052074	3	52	74	50
2542520	A4M50R0314A068100	3	68	100	50
2542521	A4M50R0314A090160	3	90	160	50
2542522	A4M50R0314A130300	3	130	300	50
2542523	A4M50R0314A290999	3	290	—	50
2542531	A4M50R0414A048072	4	48	72	50
2542532	A4M50R0414A064100	4	64	100	50
2542533	A4M50R0414A092150	4	92	150	50
2542534	A4M50R0414A132300	4	132	300	50
2542535	A4M50R0414A290999	4	290	—	50
2542541	A4M50R0519A058094	5	58	94	50
2542542	A4M50R0519A080136	5	80	136	50
2542543	A4M50R0519A120300	5	120	300	50
2542544	A4M50R0519A250999	5	250	—	50
3557131	A4M65R0624A070-112	6	70	112	65
3557163	A4M65R0624A100-212	6	100	212	65
3557165	A4M65R0624A200-999	6	200	999	65
3557167	A4M65R0824A090-200	8	90	200	65
3557169	A4M65R0824A184-999	8	184	999	65
3557173	A4M65R1024A200-999	10	200	999	65

(续)

(模块化端面切槽刀板 • 内侧 — 续)

切槽及切断

订货号	目录编号	刀片尺寸	D min	D max	刀夹尺寸
左手					
3051629	A4M50L0212A060084	2	60	84	50
3051631	A4M50L0212A120254	2	120	254	50
3051632	A4M50L0212A250999	2	250	—	50
2542524	A4M50L0314A036048	3	36	48	50
2542527	A4M50L0314A068100	3	68	100	50
2542528	A4M50L0314A090160	3	90	160	50
2542529	A4M50L0314A130300	3	130	300	50
2542530	A4M50L0314A290999	3	290	—	50
2542537	A4M50L0414A064100	4	64	100	50
2542538	A4M50L0414A092150	4	92	150	50
2542539	A4M50L0414A132300	4	132	300	50
2542540	A4M50L0414A290999	4	290	—	50
2542545	A4M50L0519A058094	5	58	94	50
2542546	A4M50L0519A080136	5	80	136	50
2542547	A4M50L0519A120300	5	120	300	50
2542548	A4M50L0519A250999	5	250	—	50
3557132	A4M65L0624A070-112	6	70	112	65
3557164	A4M65L0624A100-212	6	100	212	65
3557166	A4M65L0624A200-999	6	200	999	65
3557174	A4M65L1024A200-999	10	200	999	65



右手刀杆见图。

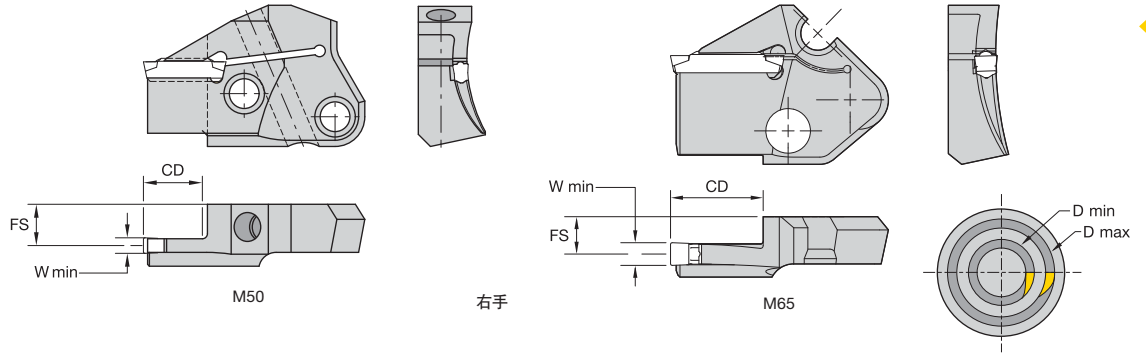

切槽及切断

■ 模块化端面切槽刀板 • 外侧

订货号	目录编号	刀片尺寸	D min	D max	CD	FS	刀夹尺寸
右手							
3051677	A4M50R0212B036046	2	36	46	12,00	10,900	50
3051678	A4M50R0212B042054	2	42	54	12,00	10,900	50
3051679	A4M50R0212B050064	2	50	64	12,00	10,900	50
3051680	A4M50R0212B060084	2	60	84	12,00	10,900	50
3051681	A4M50R0212B080124	2	80	124	12,00	10,900	50
3051682	A4M50R0212B120254	2	120	254	12,00	10,900	50
3051683	A4M50R0212B250999	2	250	—	12,00	10,900	50
3867457	A4M50R2S12B016020	2S	16	20	12,00	10,900	50
3867458	A4M50R2S12B020025	2S	20	25	12,00	10,900	50
3867459	A4M50R2S12B025036	2S	25	36	12,00	10,900	50
2398751	A4M50R0314B036048	3	36	48	14,00	10,500	50
2398752	A4M50R0314B042058	3	42	58	14,00	10,500	50
2398763	A4M50R0314B052074	3	52	74	14,00	10,500	50
2398764	A4M50R0314B068100	3	68	100	14,00	10,500	50
2398765	A4M50R0314B090160	3	90	160	14,00	10,500	50
2398766	A4M50R0314B130300	3	130	300	14,00	10,500	50
2398767	A4M50R0314B290999	3	290	—	14,00	10,500	50
2398775	A4M50R0414B048072	4	48	72	14,00	10,000	50
2398776	A4M50R0414B064100	4	64	100	14,00	10,000	50
2398777	A4M50R0414B092150	4	92	150	14,00	10,000	50
2398778	A4M50R0414B132300	4	132	300	14,00	10,000	50
2398779	A4M50R0414B290999	4	290	—	14,00	10,000	50
3867460	A4M50R3S14B020025	3S	20	25	14,00	10,490	50
3867461	A4M50R3S14B025036	3S	25	36	14,00	10,490	50
3867462	A4M50R4S14B025035	4S	25	35	14,00	10,000	50
3867464	A4M50R5S17B028038	5S	28	38	17,00	9,500	50
2398785	A4M50R0519B058094	5	58	94	19,00	9,500	50
2398786	A4M50R0519B080136	5	80	136	19,00	9,500	50
2398787	A4M50R0519B120300	5	120	300	19,00	9,500	50
2398788	A4M50R0519B250999	5	250	—	19,00	9,500	50
3557175	A4M65R0624B070-112	6	70	112	24,00	9,870	65
3557177	A4M65R0624B100-212	6	100	212	24,00	9,870	65
3557179	A4M65R0624B200-999	6	200	999	24,00	9,870	65
3557181	A4M65R0824B090-200	8	90	200	24,00	9,000	65
3557193	A4M65R0824B184-999	8	184	999	24,00	9,000	65
3557195	A4M65R1024B100-220	10	100	220	24,00	8,350	65
3557197	A4M65R1024B200-999	10	200	999	24,00	8,350	65

(续)

(模块化端面切槽刀板 • 外侧 — 续)

切槽及切断

订货号	目录编号	刀片尺寸	D min	D max	CD	FS	刀夹尺寸
左手							
3051663	A4M50L0212B036046	2	36	46	12,00	10,900	50
3051664	A4M50L0212B042054	2	42	54	12,00	10,900	50
3051665	A4M50L0212B050064	2	50	64	12,00	10,900	50
3051666	A4M50L0212B060084	2	60	84	12,00	10,900	50
3051667	A4M50L0212B080124	2	80	124	12,00	10,900	50
3051668	A4M50L0212B120254	2	120	254	12,00	10,900	50
3867466	A4M50L2S12B016020	2S	16	20	12,00	10,900	50
3867467	A4M50L2S12B020025	2S	20	25	12,00	10,900	50
3867468	A4M50L2S12B025036	2S	25	36	12,00	10,900	50
2398768	A4M50L0314B036048	3	36	48	14,00	10,500	50
2398769	A4M50L0314B042058	3	42	58	14,00	10,500	50
2398770	A4M50L0314B052074	3	52	74	14,00	10,500	50
2398771	A4M50L0314B068100	3	68	100	14,00	10,500	50
2398772	A4M50L0314B090160	3	90	160	14,00	10,500	50
2398773	A4M50L0314B130300	3	130	300	14,00	10,500	50
2398774	A4M50L0314B290999	3	290	—	14,00	10,500	50
2398780	A4M50L0414B048072	4	48	72	14,00	10,000	50
2398781	A4M50L0414B064100	4	64	100	14,00	10,000	50
2398782	A4M50L0414B092150	4	92	150	14,00	10,000	50
2398783	A4M50L0414B132300	4	132	300	14,00	10,000	50
2398784	A4M50L0414B290999	4	290	—	14,00	10,000	50
3867469	A4M50L3S14B020025	3S	20	25	14,00	10,490	50
3867470	A4M50L3S14B025036	3S	25	36	14,00	10,490	50
3867472	A4M50L4S14B035048	4S	35	48	14,00	10,000	50
3867484	A4M50L5S17B028038	5S	28	38	17,00	9,500	50
2398789	A4M50L0519B058094	5	58	94	19,00	9,500	50
2398790	A4M50L0519B080136	5	80	136	19,00	9,500	50
2398791	A4M50L0519B120300	5	120	300	19,00	9,500	50
2398792	A4M50L0519B250999	5	250	—	19,00	9,500	50
3557176	A4M65L0624B070-112	6	70	112	24,00	9,870	65
3557178	A4M65L0624B100-212	6	100	212	24,00	9,870	65
3557180	A4M65L0624B200-999	6	200	999	24,00	9,870	65
3557182	A4M65L0824B090-200	8	90	200	24,00	9,000	65
3557194	A4M65L0824B184-999	8	184	999	24,00	9,000	65
3557198	A4M65L1024B200-999	10	200	999	24,00	8,350	65

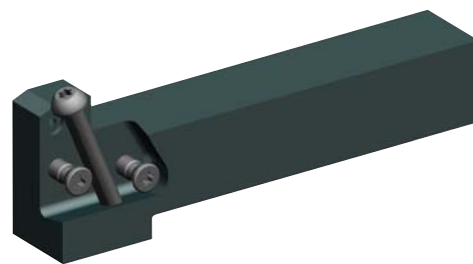
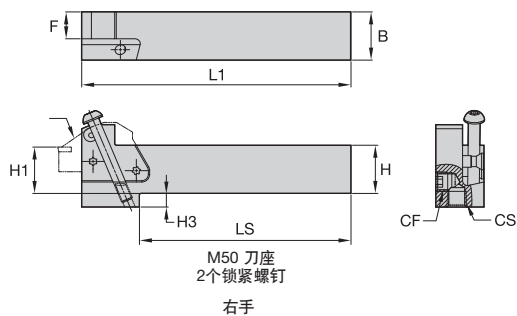

■ 模块化直型刀柄 • 公制

注: 用于机夹式带内冷直柄刀杆, 见C58.



订货号	目录编号	B	H	L1	F	LS	H3	刀片螺钉	Torx	夹紧螺钉	Torx
右手											
1600249	KGMSR2525M50	25	25	138,75	13,84	109,00	7,00	MS1162	T25	MS2002	T25
3553429	KGMSR2525M65	25	25	150,00	13,00	120,00	14,00	MS1163	T30	—	—
1621083	KGMSR3232P50	32	32	158,75	20,81	—	—	MS1162	T25	MS2002	T25
3553431	KGMSR3232P65	32	32	170,00	20,79	158,00	7,00	MS1163	T30	—	—
左手											
1600250	KGMSL2525M50	25	25	138,75	13,84	109,00	7,00	MS1162	T25	MS2002	T25
3553430	KGMSL2525M65	25	25	150,00	13,00	120,00	14,00	MS1163	T30	—	—
1621084	KGMSL3232P50	32	32	158,75	20,81	—	—	MS1162	T25	MS2002	T25
3553432	KGMSL3232P65	32	32	170,00	20,79	158,00	7,00	MS1163	T30	—	—

注: KGMS...: 右手刀柄采用右手刀板。
 KGME...: 右手刀柄采用左手刀板。
 M50 刀片及夹板螺钉力矩为 8-10 Nm (71-88 in. lbs.) 。
 M65 刀片及夹板螺钉力矩为 18-20 Nm (159-177 in. lbs.) 。

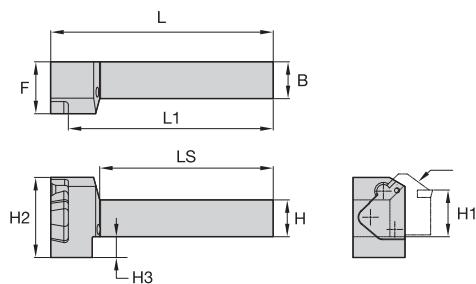

M65 刀座
2个锁紧螺钉
右手

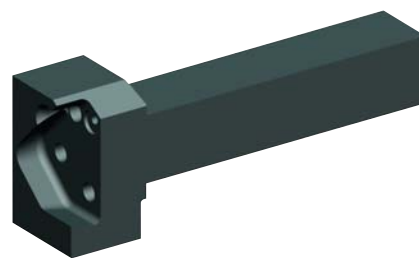

■ 模块化末端安装刀柄 • 公制

注：用于带内冷模块化刀杆。见C59.

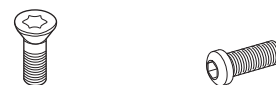

订货号	目录编号	B	H	L1	F	LS	H3	L	刀片螺钉 (2) Torx	夹紧螺钉 Torx		
右手												
1600270	KGMER2525M50	25	25	139,25	42,75	125,25	6,84	150,25	MS1162	T25	MS2002	T25
3553453	KGMER2525M65	25	25	138,15	35,00	129,00	14,00	150,00	MS1163	T30	—	—
1621085	KGMER3232P50	32	32	159,25	42,75	145,25	—	170,25	MS1162	T25	MS2002	T25
3553455	KGMER3232P65	32	32	158,15	35,00	153,00	7,00	170,00	MS1163	T30	—	—
左手												
1600271	KGME12525M50	25	25	139,25	42,75	125,25	6,84	150,25	MS1162	T25	MS2002	T25
3553454	KGME12525M65	25	25	138,15	35,00	129,00	14,00	150,00	MS1163	T30	—	—
1621086	KGME13232P50	32	32	159,25	42,75	145,25	—	170,25	MS1162	T25	MS2002	T25
3553456	KGME13232P65	32	32	158,15	35,00	153,00	7,00	170,00	MS1163	T30	—	—

注：KGMS...：右手刀柄采用右手刀板。
KGME...：右手刀柄采用左手刀板。
M50 刀片及夹板螺钉力矩为 8-10 Nm (71-88 in. lbs.)。
M65 刀片及夹板螺钉力矩为 18-20 Nm (159-177 in. lbs.)。

- 行业内一流的 KM 快换式刀具。
- 刀座具备内冷性能。
- 可换式刀板具有更好的多功能性和切深性能。

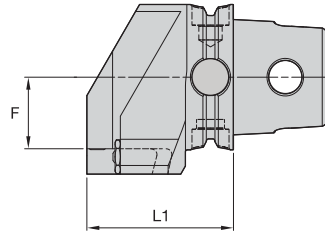
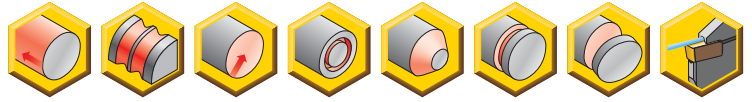

右手

切槽及切断

■ 内冷模块化直型 KM 刀柄

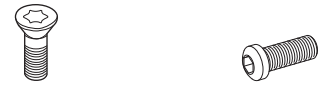

订货号	目录编号	CSMS 系统尺寸	L1	F	刀片 尺寸	刀片螺钉 Torx	夹紧螺钉 Torx
右手							
5999790	KM40TSKGMSR50C	KM40TS	53,5	15,0	50	MS1162 T25	MS2002 T25
6000422	KM50TSKGMSR65C	KM50TS	53,5	22,0	65	MS1163 T30	— —
5999864	KM50TSKGMSR50C	KM50TS	58,5	23,0	50	MS1162 T25	MS2002 T25
6000431	KM63TSKGMSR65C	KM63TS	58,5	30,0	65	MS1163 T30	— —
5999948	KM63TSKGMSR50C	KM63TS	63,5	31,0	50	MS1162 T25	MS2002 T25
5999972	KM63XMZKGMSR50CY	KM63XMZ	63,5	31,0	50	MS1162 T25	MS2002 T25
6017695	KM80TSKGMSR65C	KM80TS	63,5	40,0	65	MS1163 T30	— —
6000018	KM80ATCKGMSR50C	KM80ATC	66,5	41,0	50	MS1162 T25	MS2002 T25
6000014	KM80TSKGMSR50C	KM80TS	66,5	41,0	50	MS1162 T25	MS2002 T25
左手							
5999861	KM40TSKGMSL50C	KM40TS	53,5	15,0	50	MS1162 T25	MS2002 T25
6000424	KM50TSKGMSL65C	KM50TS	53,5	22,0	65	MS1163 T30	— —
5999865	KM50TSKGMSL50C	KM50TS	58,5	23,0	50	MS1162 T25	MS2002 T25
6000433	KM63TSKGMSL65C	KM63TS	58,5	30,0	65	MS1163 T30	— —
5999949	KM63TSKGMSL50C	KM63TS	63,5	31,0	50	MS1162 T25	MS2002 T25
5999973	KM63XMZKGMSLF50CY	KM63XMZ	63,5	31,0	50	MS1162 T25	MS2002 T25
6017696	KM80TSKGMSL65C	KM80TS	63,5	40,0	65	MS1163 T30	— —
6000019	KM80ATCKGMSL50C	KM80ATC	66,5	41,0	50	MS1162 T25	MS2002 T25
6000015	KM80TSKGMSL50C	KM80TS	66,5	41,0	50	MS1162 T25	MS2002 T25

注: KGMS...: 右手刀柄采用右手刀板。
 KGME...: 右手刀柄采用左手刀板。
 M50 刀片及夹板螺钉力矩为 8-10 Nm (71-88 in. lbs.)。
 M65 刀片及夹板螺钉力矩为 18-20 Nm (159-177 in. lbs.)。

- 行业内一流的 KM 快换式刀具。
- 刀座具备内冷性能。
- 可换式刀板具有更好的多功能性和切深性能。

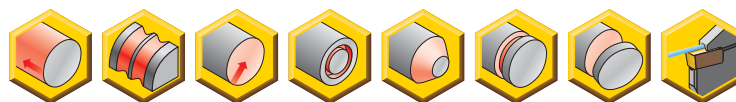

切槽及切断

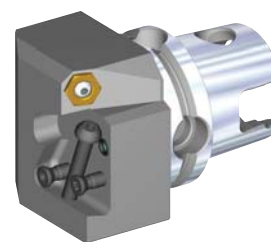
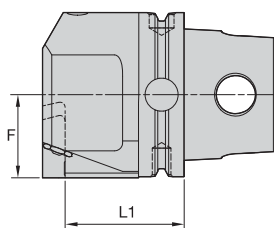

右手

■ 内冷模块化L型安装刀座 KM 刀柄 • 公制



订货号	目录编号	CSMS 系统尺寸	L1	F	刀片 尺寸	刀片螺钉	Torx	夹紧螺钉	Torx
右手									
5999788	KM40TSKGMER50C	KM40TS	28,0	20,50	50	MS1162	T25	MS2002	T25
5999862	KM50TSKGMER50C	KM50TS	38,0	25,50	50	MS1162	T25	MS2002	T25
6000410	KM50TSKGMER65C	KM50TS	47,0	25,50	65	MS1163	T30	—	—
6000425	KM63TSKGMER65C	KM63TS	47,0	32,52	65	MS1163	T30	—	—
5999946	KM63TSKGMER50C	KM63TS	48,0	32,50	50	MS1162	T25	MS2002	T25
6000434	KM63XMZKGMER65CY	KM63XMZ	47,0	32,50	65	MS1163	T30	—	—
5999950	KM63XMZKGMER50CY	KM63XMZ	48,0	32,50	50	MS1162	T25	MS2002	T25
6017697	KM80ATCKGMER65C	KM80ATC	57,0	40,50	65	MS1163	T30	—	—
6000016	KM80ATCKGMER50C	KM80ATC	58,0	40,50	50	MS1162	T25	MS2002	T25
6017693	KM80TSKGMER65C	KM80TS	57,0	40,50	65	MS1163	T30	—	—
6000012	KM80TSKGMER50C	KM80TS	58,0	40,50	50	MS1162	T25	MS2002	T25
左手									
5999789	KM40TSKGMEL50C	KM40TS	28,0	20,50	50	MS1162	T25	MS2002	T25
5999863	KM50TSKGMEL50C	KM50TS	38,0	25,50	50	MS1162	T25	MS2002	T25
6000421	KM50TSKGMEL65C	KM50TS	47,0	25,50	65	MS1163	T30	—	—
6000430	KM63TSKGMEL65C	KM63TS	47,0	32,52	65	MS1163	T30	—	—
5999947	KM63TSKGMEL50C	KM63TS	48,0	32,50	50	MS1162	T25	MS2002	T25
6000436	KM63XMZKGMELF65CY	KM63XMZ	47,0	32,50	65	MS1163	T30	—	—
5999971	KM63XMZKGMELF50CY	KM63XMZ	48,0	32,50	50	MS1162	T25	MS2002	T25
6017698	KM80ATCKGMEL65C	KM80ATC	57,0	40,50	65	MS1163	T30	—	—
6000017	KM80ATCKGMEL50C	KM80ATC	58,0	40,50	50	MS1162	T25	MS2002	T25
6017694	KM80TSKGMEL65C	KM80TS	57,0	40,50	65	MS1163	T30	—	—
6000013	KM80TSKGMEL50C	KM80TS	58,0	40,50	50	MS1162	T25	MS2002	T25

注: KGMS...: 右手刀柄采用右手刀板。
 KGME...: 右手刀柄采用左手刀板。
 M50刀片及夹板螺钉力矩为8-10 Nm (71-88 in. lbs.)。
 M65 刀板及夹具螺钉扭矩为 18-20 Nm (159-177 in. lbs.)。

- 刀座具备内冷性能。
- 可换式刀板具有更好的多功能性和切深性能。

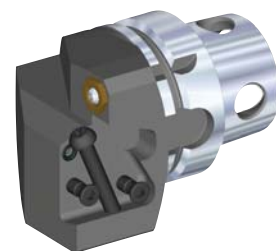
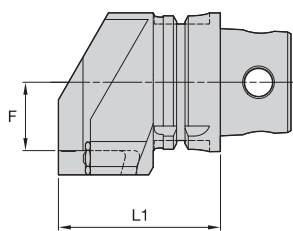

右手

切槽及切断

■ 内冷模块化直型 KM4X™ 刀柄



订货号	目录编号	CSMS 系统尺寸	L1	F	刀片 尺寸	刀片螺钉	Torx	夹紧螺钉	Torx
右手									
5543560	KM4X63KGMSR65C	KM4X63	68,5	30,0	65	MS1163	T30	—	—
6000407	KM4X63KGMSR50C	KM4X63	73,5	31,0	50	MS1162	T25	MS2002	T25
左手									
5543558	KM4X63KGMSL65C	KM4X63	68,5	30,0	65	MS1163	T30	—	—
6000408	KM4X63KGMSL50C	KM4X63	73,5	31,0	50	MS1162	T25	MS2002	T25

注: KGMS...: 右手刀柄采用右手刀板。
 KGME...: 右手刀柄采用左手刀板。
 M50刀片及夹板螺钉力矩为8-10 Nm (71-88 in. lbs.)。
 M65 刀板及夹具螺钉扭矩为 18-20 Nm (159-177 in. lbs.)。

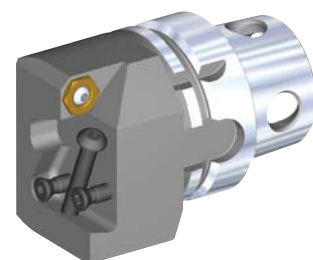
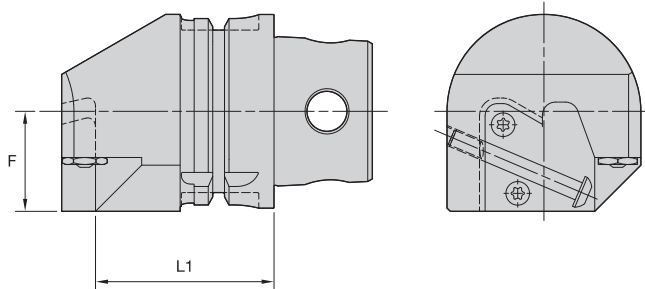

右手

■ 内冷模块化L型安装刀座 KM4X™ 刀柄

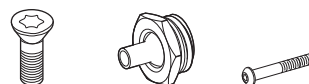

订货号	目录编号	CSMS 系统尺寸	L1	F	刀夹 尺寸	刀片螺钉	喷嘴	夹紧螺钉	kg	lbs
右手										
5543555	KM4X63KGMER65C	KM4X63	57,0	32,5	65	MS1163	PMT04525	—	1,87	4.13
6000404	KM4X63KGMER50C	KM4X63	58,0	32,5	50	MS1162	PMT04525	MS2002	1,85	4.08
6000407	KM4X63KGMSR50C	KM4X63	73,5	31,0	50	MS1162	PMT04525	MS2002	1,86	4.11
左手										
5543553	KM4X63KGME65C	KM4X63	57,0	32,5	65	MS1163	PMT04525	—	1,87	4.13
6000405	KM4X63KGME50C	KM4X63	58,0	32,5	50	MS1162	PMT04525	MS2002	1,85	4.08
6000408	KM4X63KGMSL50C	KM4X63	73,5	31,0	50	MS1162	PMT04525	MS2002	1,86	4.11

- 标准型 PSC 快换式刀具。
- 刀座具备内冷性能。
- 可换式刀片具有更好的多功能性和切深性能。

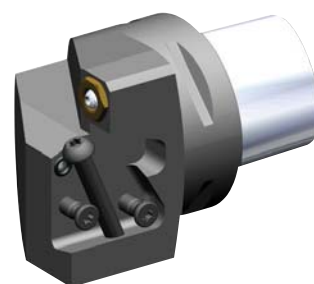
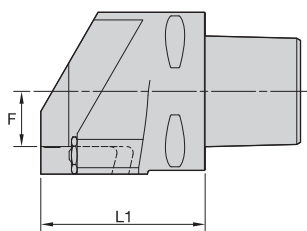
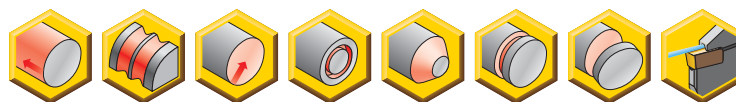

右手

■ 内冷模块化直型 PSC刀柄



订货号	目录编号	CSMS 系统尺寸	L1	F	刀片 尺寸	刀片螺钉 Torx	夹紧螺钉 Torx
右手							
6000028	PSC40KGMSR50C	PSC40	63,5	10,0	50	MS1162 T25	MS2002 T25
5405654	PSC50KGMSR65C	PSC50	49,0	25,5	65	MS1163 T30	—
6000152	PSC50KGMSR50C	PSC50	63,5	15,0	50	MS1162 T25	MS2002 T25
6000464	PSC63KGMSR65C	PSC63	60,5	21,0	65	MS1163 T30	—
6000211	PSC63KGMSR50C	PSC63	65,5	22,0	50	MS1162 T25	MS2002 T25
6000468	PSC80KGMSR65C	PSC80	68,5	29,0	65	MS1163 T30	—
6000216	PSC80KGMSR50C	PSC80	73,5	30,0	50	MS1162 T25	MS2002 T25
左手							
6000029	PSC40KGMSL50C	PSC40	63,5	10,0	50	MS1162 T25	MS2002 T25
5405655	PSC50KGMSL65C	PSC50	49,0	25,5	65	MS1163 T30	—
6000153	PSC50KGMSL50C	PSC50	63,5	15,0	50	MS1162 T25	MS2002 T25
6000465	PSC63KGMSL65C	PSC63	60,5	21,0	65	MS1163 T30	—
6000213	PSC63KGMSL50C	PSC63	65,5	22,0	50	MS1162 T25	MS2002 T25
6000469	PSC80KGMSL65C	PSC80	68,5	29,0	65	MS1163 T30	—
6000217	PSC80KGMSL50C	PSC80	73,5	30,0	50	MS1162 T25	MS2002 T25

- 标准型 PSC 快换式刀具。
- 刀座具备内冷性能。
- 可换式刀板具有更好的多功能性和切深性能。

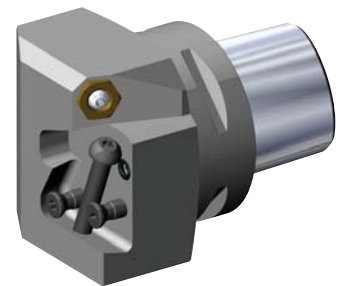
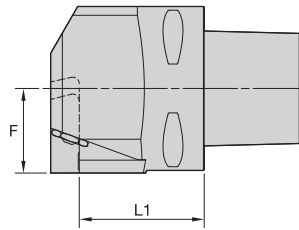
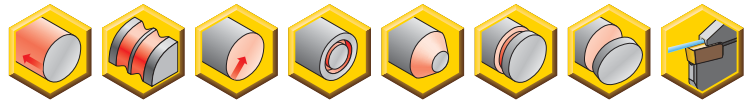

右手

切槽及切断

■ 内冷模块化L型安装刀座 PSC刀柄



订货号	目录编号	CSMS 系统尺寸	L1	F	刀片 尺寸	刀片螺钉 Torx	夹紧螺钉 Torx	
右手								
6000026	PSC40KGMER50C	PSC40	33,0	20,5	50	MS1162	T25	
6000030	PSC50KGMER50C	PSC50	43,0	25,5	50	MS1162	T25	
5405652	PSC50KGMER65C	PSC50	55,5	22,0	65	MS1163	—	
6000159	PSC63KGMER50C	PSC63	48,0	32,5	50	MS1162	T25	
6000462	PSC63KGMER65C	PSC63	49,0	32,5	65	MS1163	—	
6000466	PSC80KGMER65C	PSC80	57,0	40,5	65	MS1163	—	
6000214	PSC80KGMER50C	PSC80	58,0	40,5	50	MS1162	T25	
左手								
6000027	PSC40KGMEL50C	PSC40	33,0	20,5	50	MS1162	T25	
6000151	PSC50KGMEL50C	PSC50	43,0	25,5	50	MS1162	T25	
5405653	PSC50KGMEL65C	PSC50	55,5	22,0	65	MS1163	—	
6000160	PSC63KGMEL50C	PSC63	48,0	32,5	50	MS1162	T25	
6000463	PSC63KGMEL65C	PSC63	49,0	32,5	65	MS1163	—	
6000467	PSC80KGMEL65C	PSC80	57,0	40,5	65	MS1163	—	
6000215	PSC80KGMEL50C	PSC80	58,0	40,5	50	MS1162	T25	