

# ISO 车削刀具

<b>Kennametal 刀片选择系统</b> .....	<b>B2-B21</b>
<b>Kennametal 材质, 材质介绍及应用</b> .....	<b>B22-B29</b>
刀片断屑槽型, 进给, 切深, 及相关应用.....	<b>B30-B35</b>
方刀杆, 镗刀杆, 刀夹概览, <b>ISO</b> 代码 .....	<b>B36-B45</b>
<b>Kenloc 负角刀片、刀柄、镗杆、刀夹, 以及螺栓紧固式刀头</b> .....	<b>B46-B165</b>
<b>Kendex 正角刀片、刀柄、镗杆、刀夹, 以及螺栓紧固式刀头</b> .....	<b>B166-B174</b>
螺纹接口正角刀片、刀柄、镗杆、刀夹, 以及螺栓紧固式刀头 .....	<b>B175-B273</b>
先进材料刀片、刀柄、镗杆、刀夹, 以及螺栓紧固式刀头 .....	<b>B274-B378</b>
用于铸铁材料加工的先进材质 .....	B278-B300
用于硬车削的先进材质 .....	B302-B324
用于高温合金材料加工的先进材质.....	B326-B337
PCD 刀片.....	B338-B352
刀柄、镗杆、刀夹, 以及螺栓紧固式刀头 .....	B353-B378
可调谐镗杆.....	<b>B380-B387</b>

## 应用设备应用程序

肯纳公司移动应用程序, 可在iPhone® 和Android™设备方便地访问产品信息。我们已经列出了的一些关键特性.....

这个应用程序给您带来便利!

- |  |  |  |
|--|--|--|
| <p><b>速度和进给</b></p> <p>为金属加工产品查看速度和反馈信息。</p> | <p><b>产品可用性</b></p> <p>通过提供你的e-Konnect登录, 全球范围内查看可库存的产品及数量</p> | <p><b>计算</b></p> <p>利用计算器算出铣削和钻削的应用参数。</p> |
|--|--|--|

➔ 通过扫描刀片包装上的条形码,您可以获得的切削刀具寿命、加工时间,切屑控制的信息。

注意: 目前应用程序目前仅提供英文版本。其它语言的版本已在计划中

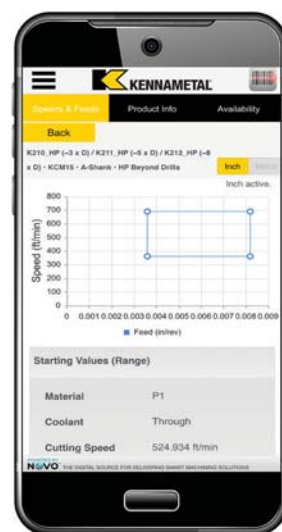

# ➤ ISO 车削刀片、刀柄、以及镗杆

先进的CNC机床及多样化的产品加工需要多用途的刀具支持。  
肯纳公司针对市场的需要研发了高性能刀片，车刀杆及镗刀杆。  
无论是加工钢件还是钛合金，无论是精加工还是重切削，  
我们都有完美的解决方案。

## 特点及优势

### Beyond™ Drive™ 刀片

- 提高生产率。
- 涂层后处理可以减少涂层应力，提高涂层的粘着性能。
- 卓越的韧性和耐磨性。
- 更好的刀片磨损识别性能。

### Beyond™ PVD 材质

#### KCU10™

- 在高温下仍具有出色的耐磨性，可以采用高速切削参数。
- 特别适合不锈钢和高温合金材料加工。
- 改善了抵御切深处缺口的能力。
- 用于精加工至一般加工。

#### KCU25™

- 卓越的切削刃韧性。
- 卓越的抗磨损性能。
- 用于一般加工至粗加工应用。

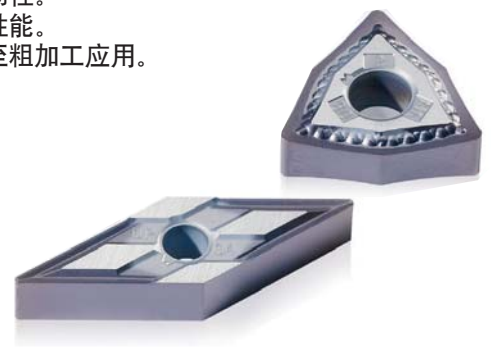

### 根据材料分类的肯纳金属车削刀具

<b>P</b> 钢	硬质合金刀片或金属陶瓷刀片
<b>M</b> 不锈钢	硬质合金刀片
<b>K</b> 铸铁	硬质合金刀片, 陶瓷刀片, 或 PcBN刀片
<b>N</b> 非铁金属	硬质合金刀片或PCD刀片
<b>S</b> 高温合金	硬质合金刀片, 陶瓷刀片, PcBN刀片, 或PCD刀片
<b>H</b> 硬材料	陶瓷刀片或 PcBN刀片

## Beyond™ Drive™ 刀片 • 技术细节

精磨刀片上下定位面

- 保证高精度的刀片定位面

超细晶粒铝涂层

- 具有很好的涂层完整性, 可以进行高速切削。
- 在进行高温切削加工时具有更高的加工效率和可靠性。

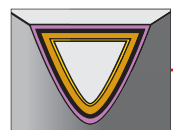

TiN/MT-TiCN/TiCN/Al<sub>2</sub>O<sub>3</sub>/TiCN

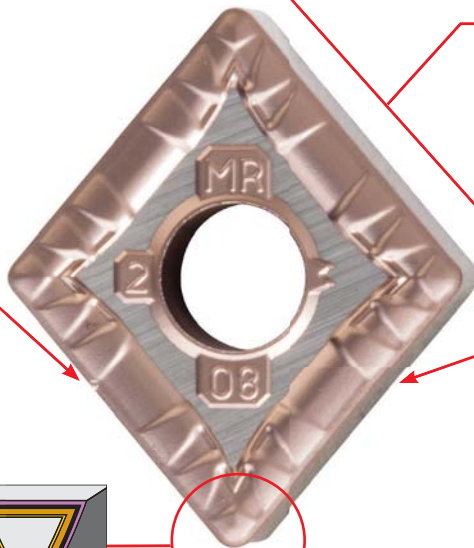

涂层去应力处理

- 改善了刀刃的韧性。
- 超长并可预测的刀具寿命。
- 减少切深处出现凹口的可能。
- 可用于多种加工应用。

精密抛光刀刃

- 改善了刀刃的韧性。
- 具有外表面光滑的特点, 可减少切削力、摩擦, 以及工件粘着的现象。

## 刀柄、镗杆及刀夹



## 如何使用目录编号？

产品目录中的每一个字符都表示产品的一个具体特征。利用下面的栏框以及对应的图形，可以容易地找到适用的刀具参数值。

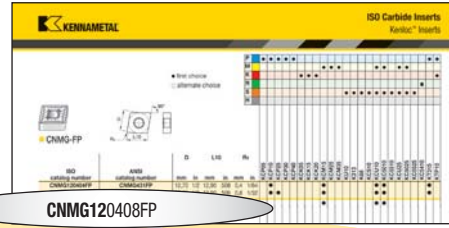

C		N		M		G		12	
刀片形状		刀片后角		公差等级		刀片特点		尺寸	
H	六角形 120°	A	3°	刃口处理和涂层处理前的 适用公差  	N	  			

这份指南使用非常方便，可以快速找到客户需要查找的产品。

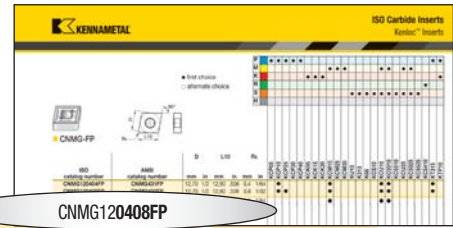

### 04

厚度  
S

图标	厚度
mm	mm
-	0,79
T0	1,00
01	1,59
T1	1,98
02	2,38
03	3,18
T3	3,97
04	4,76
05	5,56
06	6,35
07	7,94
9	9,52
11	11,11
12	12,70

### 08

刀尖  
半径 "Rε"

图标	圆角
mm	mm
X0	0,04
01	0,1
02	0,2
04	0,4
08	0,8
12	1,2
16	1,6
20	2,0
24	2,4
28	2,8
32	3,2
00	圆形 刀片
M0	
-	-

刀片方向  
(可选)

R = 右手  
L = 左手  
N = 中性

切削刃  
(可选)

F		尖角型
E		圆角型
T		倒角型
S		倒角圆形
K		双倒角
P		双倒角 及圆形

### FP

断屑器  
(可选)

F	= 尖角型
FF	= 精加工
FN	= 负前角精加工
MN	= 负前角一般加工
MR	= 一般粗加工
RN	= 负前角粗加工
UN	= 通用一般加工
FP	= 正前角精加工
MP	= 正前角一般加工
RP	= 正前角粗加工
RM	= 一般粗加工
RH	= 重载粗加工
FW	= 精加工修光刃
MW	= 一般加工修光刃
FS	= 精加工, 刃口锋利
MS	= 一般加工, 刃口锋利
RW	= 粗加工修光刃
HP	= 大正前角
UP	= 正前角通用加工
K	= 低进给切屑控制
UF	= 超精加工
LF	= 轻型精加工
MF	= 一般精加工
E	= 仅倒圆
T	= 负倒棱
S	= 负倒棱加倒圆
MP-K	= 正前角一般加工
MG-P	= 正前角一般加工

"D"	"D"公差±				"B"公差±				
	形状 S, T, C, R, & W	M级公差		U级公差	形状 S, T, C, R, & W	M级公差		U级公差	形状 S, T, & C
		形状 D	形状 V	形状 S, T, & C		形状 D	形状 V	形状 S, T, & C	
mm	mm	mm	mm	mm	mm	mm	mm	mm	
3,97	0,05	-	-	-	3,97	0,08	-	-	-
4,76	0,05	-	-	0,08	4,76	0,08	-	-	0,13
5,56	0,05	0,05	0,05	0,08	5,56	0,08	0,11	-	0,13
6,35	0,05	0,05	0,05	0,08	6,35	0,08	0,11	-	0,13
7,94	0,05	0,05	0,05	0,08	7,94	0,08	0,11	-	0,13
9,52	0,05	0,05	0,05	0,08	9,52	0,08	0,11	0,18	0,13
11,11	0,08	0,08	0,08	0,13	11,11	0,13	0,15	-	-
12,70	0,08	0,08	0,08	0,13	12,70	0,13	0,15	0,25	0,20
14,29	0,08	0,08	0,08	0,13	14,29	0,13	0,15	-	-
15,88	0,10	0,10	0,10	0,18	15,88	0,15	0,18	-	0,27
17,46	0,10	0,10	0,10	0,18	17,46	0,15	0,18	-	0,27
19,05	0,10	0,10	0,10	0,18	19,05	0,15	0,18	-	0,27
22,22	0,13	-	-	0,25	22,22	0,15	-	-	0,38
25,40	0,13	-	-	0,25	25,40	0,18	-	-	0,38
31,75	0,15	-	-	0,25	31,75	0,20	-	-	0,38

一个关于材质、槽型、以及应用指南的系统，可以为金属切削行业的客户提供最佳的产品解决方案。可以方便地找到适合特定材料工件以及特定应用类型，具有切屑控制性能的，最佳kennametal切削刀具产品！

■ 材质 • Beyond™ • Beyond™ Drive™

beyond

beyond DRIVE™

<b>K</b>	<b>C</b>	<b>P</b>	<b>M</b>	<b>25</b>	<b>B</b>														
品牌	刀片材料	首选工件材料 (ISO 513)	备选工件材料 (可选)	应用范围	未来产品升级 (可选)														
<p><b>K</b> = Kennametal</p>		<table border="1"> <tr><td><b>P</b></td><td>钢</td></tr> <tr><td><b>M</b></td><td>不锈钢</td></tr> <tr><td><b>K</b></td><td>铸铁</td></tr> <tr><td><b>N</b></td><td>非铁金属</td></tr> <tr><td><b>S</b></td><td>高温合金</td></tr> <tr><td><b>H</b></td><td>硬材料</td></tr> <tr><td><b>U</b></td><td>通用加工</td></tr> </table>	<b>P</b>	钢	<b>M</b>	不锈钢	<b>K</b>	铸铁	<b>N</b>	非铁金属	<b>S</b>	高温合金	<b>H</b>	硬材料	<b>U</b>	通用加工			<p><b>B</b> = Beyond™ Drive™ <b>C</b> = 第三代, 等</p>
<b>P</b>	钢																		
<b>M</b>	不锈钢																		
<b>K</b>	铸铁																		
<b>N</b>	非铁金属																		
<b>S</b>	高温合金																		
<b>H</b>	硬材料																		
<b>U</b>	通用加工																		
	<p>毛坯 = 硬质合金, 未经涂层处理 <b>C</b> = 硬质合金, 经过涂层处理 <b>T</b> = 金属陶瓷 <b>Y</b> = 陶瓷 <b>D</b> = PCD <b>B</b> = PcBN</p>		<p>硬度最大 ↑ 5 完工精加工 10 精加工 15 一般加工至粗加工 20 25 粗加工 30 35 40 45 重型粗加工 50 ↓ 韧性最强</p>																

注意: 应用范围不适合PcBN材质。

## 正前角刀片



### 螺纹接口刀片

- 螺纹接口刀片是各类材料工件内圆车削加工的首选产品，并且也是小型至中型车床进行外圆车削加工的首选产品。
- 有压铸和磨制的平板和切屑控制槽型可选。适合各类材料工件。

参看页码:

硬质合金: B175-B273

超硬材料: B284-B351

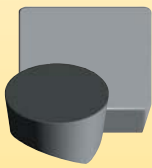

### Kendex™和V形底刀片

- Kendex 正前角和V形底刀片是中型至大型车床加工高温合金工件的首选高效刀片。
- 提供周边磨削的平板槽型。

参看页码:

硬质合金: B166-B168

超硬材料: B284-B351



### Top Notch™ 仿形刀片

- 高效仿形加工的首选产品。
- 独特的刀片夹持设计具有卓越的刚性。
- 有压制和磨制的切屑控制槽型可选。适合各类材料工件。

产品列表请参看 E20-E43 页。



### K-Lock™ 刀片

- K-Lock 刀片是深切槽和仿形加工的理想产品。
- 一种独特的刀片夹持系统，具有顺畅的切屑流。
- 提供经过压铸并且周边经磨削处理的产品。

产品列表请参看 E62-E65 页。

## 负前角刀片



### Kenloc™ 刀片

- Kenloc 刀片是中型至大型车床对各种材质工件进行通用加工的首选产品。
- Kenloc 刀片在高金属切除率加工中具有最佳的经济性能。
- 有压铸和磨制的平板和切屑控制槽型可选。适合各类材料工件。

参看页码:

硬质合金: B46-B165

超硬材料: B284-B351



### Kendex 刀片

- Kendex 陶瓷刀片是对高温合金工件进行高效加工的理想产品。
- Kendex 负前角刀片也是淬火材质和铸铁工件加工的首选产品。
- 有压铸和磨制的平板槽型可选。
- 有多种标准刀柄可供选择。

产品列表请参看 B284-B351 页。



### Top Notch 车削刀片

- Top Notch 陶瓷车削刀片是对铸铁工件进行高速粗加工和精加工的首选产品。
- 有压铸和磨制的平板槽型可选。

产品列表请参看 B284-B351 页。



### Fix-Perfect™ 刀片

- 正切设计及稳定的夹持系统。

具体产品参考E2-E18页。



### 火车轮刀片

- 针对于火车轮及轮轴加工。

具体产品参考E44-E61页。

## 刀片选择系统

### 如何使用

肯纳金属刀片选择系统分为三个步骤，选择高效刀具易如反掌。刀具推荐是以六种工件材料分组为基础，使刀具选择的精确性达到最大化。

### 举例： 六种工件材料分组

#### ■ 步骤一 • 选择刀片槽型

如果： 切削深度 = 1 mm  
进给量为 = 0.4 mm  
未知： 刀片槽型  
解决方案： -MN

#### ■ 步骤2 • 选择刀片材质

如果： 切削条件：  
轻微断续切削   
槽型： -MN  
未知： 材质  
解决方案： KCP25B

#### ■ 步骤3 • 选择切削速度

如果： 材质 KCP25B  
切削条件  
材料 CK15   
未知： 切削速度  
解决方案 280 m/min

选择产品需要帮助吗？  
了解其它信息，请联系  
肯纳客户应用支持团队。  
登录 [kennametal.com](http://kennametal.com) 网站，了解在当地的客户产品支持部门电话号码。



### 步骤1 • 选择刀片槽型

负前角刀片

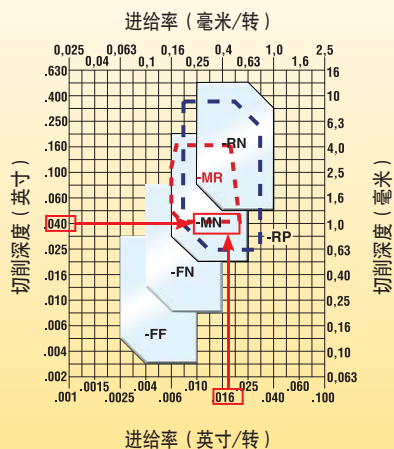

\* -RP - 加工高强度材料工件的其它槽型

P	钢
M	不锈钢
K	铸铁
N	非铁金属
S	高温合金
H	硬材料



### 步骤2 • 选择刀片材质

切削条件	-FF	-FN	-MN	-RN	-RP	-11	-UF	-LF	-FP	-MF	-MP
重型断续切削	KCP10B/ KCP10	KCP25B/ KCP25	KCP30B/ KCP30	KCP30B/ KCP30/ KCP40B/ KCP40	KCP30B/ KCP30/ KCP40B/ KCP40	-	KCU10/ KCP25B/ KCP25	KCP25B/ KCP25	KCU25/ KCP25B/ KCP25	KCP40B/ KCP40B	KCP40B/ KCP40B
轻微断续切削	KCP10B/ KCP10	KCP25B/ KCP25	KCP25B/ KCP25	KCP30B/ KCP30/ KCP40B/ KCP40	KCP30B/ KCP30/ KCP40B/ KCP40	-	KCU10/ KCP25B/ KCP25	KCP25B/ KCP25	KCP25B/ KCP25	KCP25B/ KCP25	KCP25B/ KCP25
变深切削, 铸造、或锻造表皮	KCP05B/ KCP05/ KT315	KCP10B/ KCP10	KCP10B/ KCP10	KCP30B/ KCP30/ KCP40B/ KCP40	KCP30B/ KCP30/ KCP40B/ KCP40	KT315	KCP10B/ KCP10	KCP10B/ KCP10	KCP10B/ KCP10	KCP10B/ KCP10	KCP10B/ KCP10

### 步骤3 • 选择切削速度

低碳钢 (<0,3% C) 和快削钢

切削速度 - 米/分钟 (SFM)

初始条件

材料组	材质	切削速度 - 米/分钟 (SFM)								初始条件		
		135 (450)	180 (600)	225 (800)	275 (900)	320 (1050)	360 (1200)	410 (1350)	455 (1500)	495 (1650)	米/分钟	SFM
P1	KCP05B/KCP05/KTP10										435	1450
	KCP10B/KCP10										395	1320
	KCP25B/KCP25										275	925
	KCP30B/KCP30/KCP40B/KCP40										210	700

新型 Beyond™ 材料分组选择指南:

为了使切削速度的选择更加优化, 在六种工件材料分组的基础上又添加了 Beyond 材料分组。

材料	材料分组 ISO 代码	材料分组号码
钢	P	1-6
不锈钢	M	1-3
铸铁	K	1-3
非铁金属	N	1-8
高温合金	S	1-4
硬化材料	H	1

### 步骤1 • 选择刀片槽型



负角修光刀片

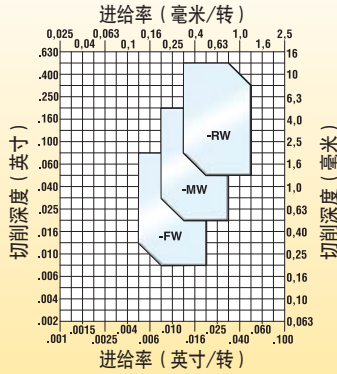

正角修光刀片

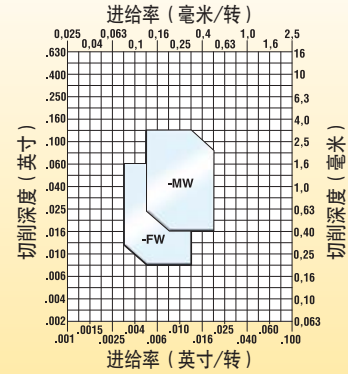

### 步骤2 • 选择刀片材质

切削条件	负角刀片槽型			正角刀片槽型	
	-FW	-MW	-RW	-FW	-MW
重型断续切削	-	-	KCP25B/KCP25	-	KCP25B/KCP25
轻微断续切削	KCP10B/KCP10	KCP25B/KCP25	KCP25B/KCP25	KCP25B/KCP25	KCP25B/KCP25
变深切削, 铸造、或锻造表皮	KCP05B/KCP05/ KT315	KCP10B/KCP10	KCP10B/KCP10	KCP10B/KCP10/ KCK20B/KCK20	KCP10B/KCP10
平滑切削、预车削表面	KCP05B/KCP05/ KT315	KCP05B/KCP05	KCP10B/KCP10	KCP10B/KCP10/ KT315	KT315

### 步骤1 • 选择刀片槽型

负前角刀片

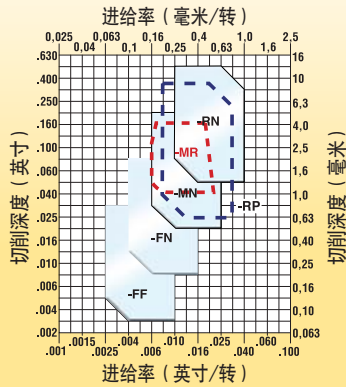

正前角刀片

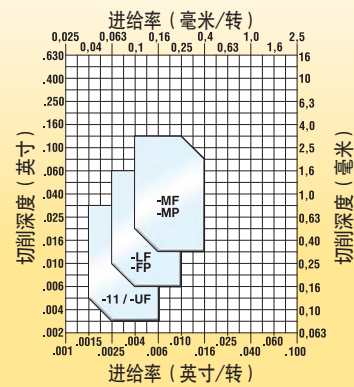

\* -RP -- 加工高强度材料工件的其它槽型

### 步骤2 • 选择刀片材质

切削条件	负前角刀片						正前角刀片					
	-FF	-FN	-MN	-MR	-RN	-RP	-11	-UF	-LF	-FP	-MF	-MP
重型断续切削	KCP10B/ KCP10	KCP25B/ KCP25	KCP30B/ KCP30	-	KCP30B/ KCP40B	KCP30B/ KCP40B	-	KCU10/ KCP25B/ KCP25	KCP25B/ KCP25	KCP25B/ KCP25	KCP40B/ KCP40	KCM25B/ KCM25
轻微断续切削	KCP10B/ KCP10	KCP25B/ KCP25	KCP25B/ KCP25	KCP25B/ KCP25	KCP25B/ KCP25	KCP25B/ KCP25	-	KCU10/ KCP25B/ KCP25	KCP25B/ KCP25	KCP25B/ KCP25	KCP25B/ KCP25	KCP25B/ KCP25
变深切削, 铸造、或锻造表皮	KCP05B/ KCP05/ KT315	KCP10B/ KCP10	KCP10B/ KCP10	KCP10B/ KCP10	KCP10B/ KCP10	KCP10B/ KCP10	KT315	KCP10B/ KCP10	KCP10B/ KCP10	KCP10B/ KCP10	KCP10B/ KCP10	KCP10B/ KCP10
平滑切削、预车削表面	KCP05B/ KCP05/ KT315	KCP05B/ KCP05	KCP05B/ KCP05	KCP10B/ KCP10/ KCK15B	KCP05B/ KCP10	KCP05B/ KCP10	KT315	KCP05B/ KCP05	KCP05B/ KCP05/ KT315	KCP05B/ KCP05/ KTP10	KCP05B/ KCP05	KCP05B/ KCP05

**步骤3 • 选择切削速度**

低碳钢 (&lt;0,3% C) 和快削钢

切削速度米 - 米/分钟 (SFM)

初始条件

材料组	材质	135 (450)	180 (600)	225 (800)	275 (900)	320 (1050)	360 (1200)	410 (1350)	455 (1500)	495 (1650)	米/分钟	SFM
P0/P1	KCP05B/KCP05/KCPK05	◇									435	1450
	KCP10B/KCP10	◇									395	1320
	KCP25B/KCP25	◇									275	925
	KCP30B/KCP30/KCP40B/KCP40	◇									210	700
	KT315/KTP10	◇									440	1450
	KCU10	◇									280	925

中碳和高碳钢 (&gt;0,3% C)

切削速度米 - 米/分钟 (SFM)

初始条件

材料组	材质	135 (450)	180 (600)	225 (800)	275 (900)	320 (1050)	360 (1200)	410 (1350)	455 (1500)	495 (1650)	米/分钟	SFM
P2	KCP05B/KCP05/KCPK05	◇									240	800
	KCP10B/KCP10	◇									265	880
	KCP25B/KCP25	◇									195	650
	KCP30B/KCP30/KCP40B/KCP40	◇									150	500
	KT315/KTP10	◇									270	880
	KCU10	◇									200	650

合金钢和工具钢 (≤330 HB) (≤35 HRC)

切削速度米 - 米/分钟 (SFM)

初始条件

材料组	材质	135 (450)	180 (600)	225 (800)	275 (900)	320 (1050)	360 (1200)	410 (1350)	455 (1500)	495 (1650)	米/分钟	SFM
P3	KCP05B/KCP05/KCPK05	◇									205	680
	KCP10B/KCP10	◇									190	630
	KCP25B/KCP25	◇									155	510
	KCP30B/KCP30/KCP40B/KCP40	◇									120	400
	KT315/KTP10	◇									210	680
	KCU10	◇									155	510

合金钢和工具钢 (330-450 HB) (36-48 HRC)

切削速度米 - 米/分钟 (SFM)

初始条件

材料组	材质	60 (200)	90 (300)	120 (400)	150 (500)	180 (600)	210 (700)	240 (800)	270 (900)	300 (1000)	米/分钟	SFM
P4	KCP05B/KCP05/KCPK05	◇									160	530
	KCP10B/KCP10	◇									145	480
	KCP25B/KCP25	◇									105	360
	KCP30B/KCP30/KCP40B/KCP40	◇									95	325
	KT315/KTP10	◇									210	530
	KCU10	◇									110	360

铁素体、马氏体、和 PH 不锈钢 (≤330 HB) (≤35 HRC)

切削速度米 - 米/分钟 (SFM)

初始条件

材料组	材质	120 (400)	150 (500)	180 (600)	210 (700)	240 (800)	270 (900)	300 (1000)	330 (1100)	360 (1200)	米/分钟	SFM
P5	KCP05B/KCP05/KCPK05	◇									240	800
	KCP10B/KCP10	◇									215	720
	KCP25B/KCP25	◇									195	650
	KCP30B/KCP30/KCP40B/KCP40	◇									135	450
	KT315/KTP10	◇									250	800
	KCU10	◇									200	660

铁素体、马氏体、和 PH 不锈钢 (340-450 HB) (36-48 HRC)

切削速度米 - 米/分钟 (SFM)

初始条件

材料组	材质	105 (350)	135 (450)	165 (550)	195 (650)	225 (750)	255 (850)	285 (950)	315 (1050)	345 (1150)	米/分钟	SFM
P6	KCP05B/KCP05/KCPK05	◇									200	660
	KCP10B/KCP10	◇									180	600
	KCP25B/KCP25	◇									150	500
	KCP30B/KCP30/KCP40B/KCP40	◇									105	350
	KT315/KTP10	◇									200	660
	KCU10	◇									150	500

■ 步骤一 • 选择刀片槽型

负角修光刃刀片

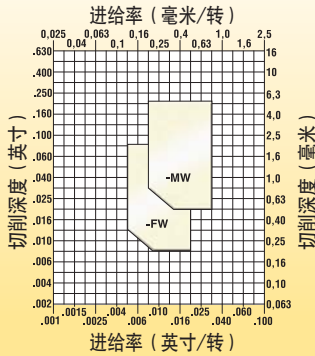

正角修光刃刀片

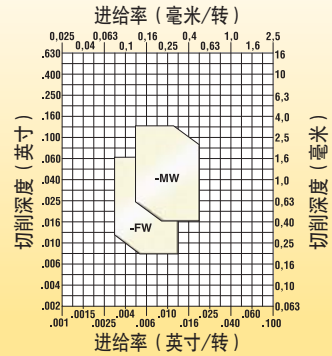

■ 步骤二 • 选择刀片材质

切削条件	负角刀片槽型		正角刀片槽型	
	-FW	-MW	-FW	-MW
重型断续切削	-	-	-	-
轻微断续切削	KCM15B/KCM15	KCM25B/KCM25	KCM15B/KCM15	KCM15B/KCM15
变深切削, 铸造、或锻造表皮	KCM15B/KCM15/ KCU10	KCM15B/KCM15	KCU10	KCU10
平滑切削、预车削表面	KCM15B/KCM15/ KT315	KCM15B/KCM15	KT315	KT315

■ 步骤一 • 选择刀片槽型

负前角刀片

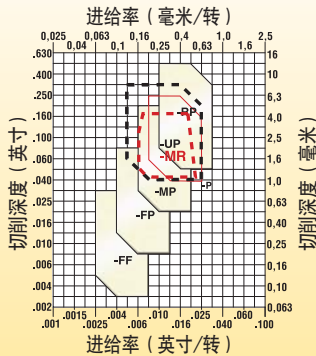

正前角刀片

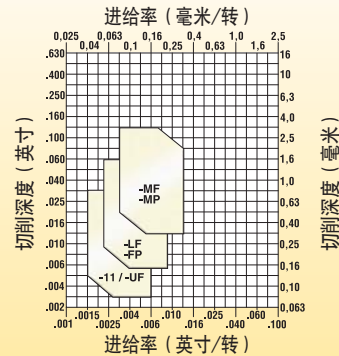

■ 步骤二 • 选择刀片材质

切削条件	负角刀片槽型				
	-FF	-FP	-MP/-UP	-P/-RP	-MR
重型断续切削	KCU10	KCM15B/KCM15	KCM35B/KCM35	KCM35B/KCM35	KCM35B/KCM35
轻微断续切削	KCU10	KCM15B/KCM15	KCM25B/KCM25	KCM25B/KCM25	KCM25B/KCM25
变深切削, 铸造、或锻造表皮	KT315	KCM15B/KCM15/ KCU10	KCM15B/KCM15	KCM15B/KCM15/ KCM25B/KCM25	KCM15B/KCM15
平滑切削、预车削表面	KT315	KCM15B/KCM15/ KT315	KCM15B/KCM15/ KCU10	KCU10	KCM15B/KCM15

(续)

**步骤二 • 选择刀片材质 (续)**

切削条件	正角刀片槽型						
	-11	-UF	-LF	-MP/-MF	-FP	..GT-LF	
重型断续切削		-	KCU25	KCM35B/KCM35	KCM25B/KCM25	KCU25/KCM25B/KCM25	KCU25
轻微断续切削		-	KCU10	KCM25B/KCM25	KCM25B/KCM25	KCM15B/KCM15	KCU25
变深切削, 铸造、或锻造表皮		KT315	-	KCM15B/KCU10	KCM15B/KCM15	KCU10	KCU10
平滑切削、预车削表面		KT315	-	KCM15B/KCM15/ KT315	KCM15B/KCM15	KTP10	KCU10

**步骤三 • 选择切削速度**

奥氏体不锈钢 切削速度 - 米/分钟 (SFM) 初始条件

材料组	材质	切削速度 - 米/分钟 (SFM)									初始条件	
		90 (300)	135 (450)	180 (600)	225 (800)	270 (900)	315 (1050)	360 (1200)	405 (1350)	450 (1500)	米/分钟	SFM
M1	KCM15B/KCM15			◇							180	600
	KCM25B/KCM25		◇								150	500
	KCM35B/KCM35	◇									120	400
	KT315				◇						230	750
	KCU10				◇						215	700
	KCU25		◇								180	550

奥氏体不锈钢 切削速度 - 米/分钟 (SFM) 初始条件

材料组	材质	切削速度 - 米/分钟 (SFM)									初始条件	
		90 (300)	135 (450)	180 (600)	225 (800)	270 (900)	315 (1050)	360 (1200)	405 (1350)	450 (1500)	米/分钟	SFM
M2	KCM15B/KCM15			◇							165	550
	KCM25B/KCM25		◇								140	450
	KCM35B/KCM35	◇									105	350
	KT315				◇						215	700
	KCU10				◇						200	650
	KCU25		◇								165	500

奥氏体不锈钢: 双相不锈钢 (铁素体及奥氏体) 切削速度 - 米/分钟 (SFM) 初始条件

材料组	材质	切削速度 - 米/分钟 (SFM)									初始条件	
		90 (300)	135 (450)	180 (600)	225 (800)	270 (900)	315 (1050)	360 (1200)	405 (1350)	450 (1500)	米/分钟	SFM
M3	KCM15B/KCM15			◇							150	500
	KCM25B/KCM25		◇								120	400
	KCM35B/KCM35	◇									90	300
	KT315				◇						200	650
	KCU10				◇						185	600
	KCU25		◇								150	450

■ 步骤1 • 选择刀片槽型

负角修光刃刀片

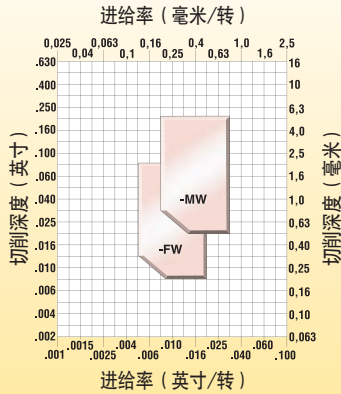

正角修光刃刀片

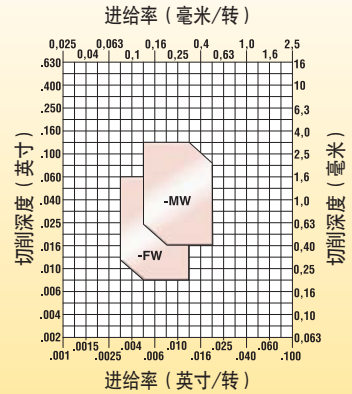

■ 步骤2 • 选择刀片材质

灰铸铁

切削条件	负角刀片槽型			正角刀片槽型	
	-FW	-T-20FW	-S...MW...	-FW	-MW
重型断续切削	-	KY3500	KB1345	-	KCK15B/KCK15/ KCK20B/KCK20
轻微断续切削	KCK15B/KCK15	KY3500	KB1345	KCK20B/KCK20	KCK15B/KCK15/ KCK20B/KCK20
不同深度的切削, 铸造、或锻造表皮	KCK05B/KCK05/ KT315	KYK10	KB1345	KCK20B/KCK20	KCK15B/KCK15/ KCK20B/KCK20
平滑切削、预车削表面	KCK05B/KCK05/ KT315	KYK25	KB1345	KCK20B/ KT315	KCK15B/KCK15/ KCK20B/KCK20/KT315

球墨铸铁

切削条件	负角刀片槽型		正角刀片槽型	
	-FW	-T-20FW	-FW	-MW
重型断续切削	-	-	-	-
轻微断续切削	KCK15B/ KCK15	KY3500	KCK20B/ KCK20	KCK20B/ KCK20
不同深度的切削, 铸造、或锻造表皮	KCK05B/KCK05/ KT315	KYK10	KCK20B/ KCK20	KCK20B/ KCK20
平滑切削、预车削表面	KCK05B/KCK05/ KT315	KYK25	KCK20B/KCK20/ KT315	KCK20B/KCK20/ KT315

**步骤3 • 选择切削速度**

灰铸铁

材料组	材质	切削速度 - 米/分钟 (SFM)									初始条件	
		60 (200)	150 (500)	240 (800)	330 (1100)	420 (1400)	510 (1700)	600 (2000)	690 (2300)	780 (2600)	米/分钟	SFM
K1	KCK05B/KCK05										450	1500
	KCK15B/KCK15										360	1200
	KCK20B/KCK20/KCPK05										300	1000
	KT315										275	900

球磨铸铁、蠕墨铸铁, 以及可锻铸铁  
(抗拉强度 < 80 KSI)

材料组	材质	切削速度 - 米/分钟 (SFM)									初始条件	
		60 (200)	150 (500)	240 (800)	330 (1100)	420 (1400)	510 (1700)	600 (2000)	690 (2300)	780 (2600)	米/分钟	SFM
K2	KCK05B/KCK05										360	1200
	KCK15B/KCK15										270	900
	KCK20B/KCK20/KCPK05										240	800
	KT315										275	900

球磨铸铁、蠕墨铸铁, 以及可锻铸铁  
(抗拉强度 > 80 KSI)

材料组	材质	切削速度 - 米/分钟 (SFM)									初始条件	
		60 (200)	150 (500)	240 (800)	330 (1100)	420 (1400)	510 (1700)	600 (2000)	690 (2300)	780 (2600)	米/分钟	SFM
K3	KCK05B/KCK05										240	800
	KCK15B/KCK15										215	725
	KCK20B/KCK20/KCPK05										210	700
	KT315										230	750

■ 步骤1 • 选择刀片槽型



负前角刀片

正前角刀片

进给率 (毫米/转)

进给率 (英寸/转)

切削深度 (英寸)

切削深度 (毫米)

进给率 (毫米/转)

进给率 (英寸/转)

切削深度 (英寸)

切削深度 (毫米)

\* 可以用于一般加工的槽型，并在高强度金属加工中降低刀具压力。

■ 步骤2 • 选择刀片材质

灰铸铁

切削条件	负角刀片槽型				正角刀片槽型			
	-FN	-MR	-UN(-RP)	-MA	-LF	-FP	-MF	-MP
重型断续切削	KCK15B/ KCK15	KCP25B/ KCP25/ KCP10B/KCP10	KCK20B/ KCK20	KCK20B/ KCK20	KCK20B/ KCK20	KCK20B/ KCK20	KCK20B/ KCK20	KCK20B/ KCK20
轻微断续切削	KCK15B/ KCK15	KCP10B/ KCP10/ KCP25B/KCP25	KCK20B/ KCK20	KCK20B/ KCK20	KCK20B/ KCK20	KCK20B/ KCK20	KCK20B/ KCK20	KCK20B/ KCK20
变深切削，铸造、或锻造表皮	KCK05B/ KCK05/ KT315	KCK15B/ KCK15	KCK15B/ KCK15	KCK15B/ KCK15	KCK15B/ KCK15	KCK20B/ KCK20	KCK15B/ KCK15	KCK20B/ KCK20
平滑切削、预车削表面	KCK05B/ KCK05/ KT315	KCK15B/ KCK15	KCK05B/ KCK05	KCK05B/ KCK05	KCK05B/ KCK05	KCK20B/ KCK20	KCK15B/ KCK15	KCK20B/ KCK20

球墨铸铁

切削条件	负角刀片槽型				正角刀片槽型			
	-FN	-UN(-RP)	-MA	-11/-UF	-LF	-MF	-FP	-MP
重型断续切削	KCK15B/ KCK15	KCK20B/ KCK20	KCK20B/ KCK20	-	KCK20B/ KCK20	KCK20B/ KCK20	KCK20B/ KCK20	KCK20B/ KCK20
轻微断续切削	KCK15B/ KCK15	KCK20B/ KCK20	KCK20B/ KCK20	KCU10	KCK20B/ KCK20	KCK20B/ KCK20	KCK20B/ KCK20	KCK20B/ KCK20
变深切削，铸造、或锻造表皮	KCK05B/ KCK05/ KT315	KCK15B/ KCK15	KCK15B/ KCK15	KCU10	KCK15B/ KCK15	KCK15B/ KCK15	KCK20B/ KCK20	KCK20B/ KCK20
平滑切削、预车削表面	KCK05B/ KCK05/ KT315	KCK05B/ KCK05	KCK05B/ KCK05	KT315	KCU10	KCK15B/ KCK15	KCK20B/ KCK20	KCK20B/ KCK20

(续)



**■ 步骤三 • 选择切削速度 (续)**

(优化的切削速度取决于铸造质量和设备配置)

灰铸铁

切削速度 — 米/分钟 (SFM)

初始条件

材料组	材质	60 (200)	180 (600)	305 (1000)	430 (1400)	550 (1800)	675 (2200)	800 (2600)	920 (3000)	1040 (3400)	1160 (3800)	米/分钟	SFM
<b>K1</b>	KT315	◇										275	900
	KB1340/KB1345	◇										760	2500
	KCK05B/KCK05	◇										450	1500
	KCK15B/KCK15	◇										360	1200
	KCK20B/KCK20/KCPK05	◇										300	1000

 球磨铸铁、蠕墨铸铁, 以及可锻铸铁  
 (<抗拉强度 600 MPa)

切削速度 — 米/分钟 (SFM)

初始条件

材料组	材质	90 (300)	135 (450)	180 (600)	225 (750)	275 (900)	320 (1050)	360 (1200)	410 (1350)	460 (1500)	500 (1650)	550 (1800)	600 (1950)	米/分钟	SFM
<b>K2</b>	KT315	◇										275	900		
	KCU10	◇										200	650		
	KCK05B/KCK05	◇										360	1200		
	KCK15B/KCK15	◇										270	900		
	KCK20B/KCK20/KCPK05	◇										240	800		

 球磨铸铁、蠕墨铸铁, 以及可锻铸铁  
 (>抗拉强度 600 MPa)

切削速度 — 米/分钟 (SFM)

初始条件

材料组	材质	90 (300)	135 (450)	180 (600)	225 (750)	275 (900)	320 (1050)	360 (1200)	410 (1350)	460 (1500)	500 (1650)	550 (1800)	600 (1950)	米/分钟	SFM
<b>K3</b>	KT315	◇										230	750		
	KCU10	◇										150	500		
	KCK05B/KCK05	◇										240	800		
	KCK15B/KCK15	◇										215	725		
	KCK20B/KCK20/KCPK05	◇										210	700		

■ 步骤1 • 选择刀片槽型



负角刀片



一般精加工

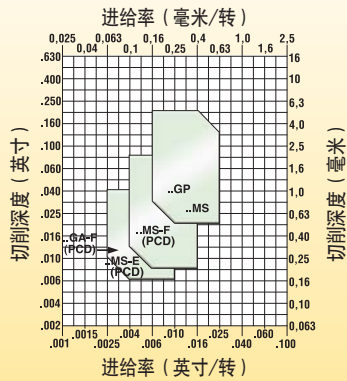

正角刀片



一般精加工



精加工

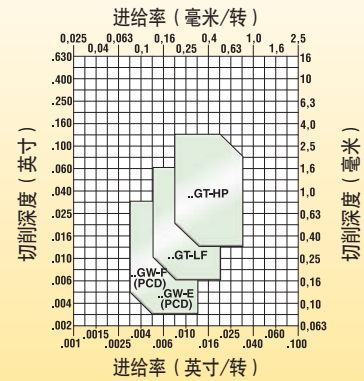

■ 步骤2 • 选择刀片材质

负角刀片槽型

正角刀片槽型

切削条件		..GP	..MS	..GT-LF	..GT-HP
重型断续切削		KC5410/K313	KC5410	-	KC5410
轻微断续切削		KC5410/K313	KC5410	KC5410	KC5410
变深切削, 铸造、或锻造表皮		KC5410/K313	KC5410	KC5410	KC5410
平滑切削、预车削表面		KC5410/K313	KC5410	KC5410	KC5410

■ 步骤3 • 选择切削速度

低硅铝合金  
(亚共晶体<12.2% Si) 和锰合金

切削速度 - 米/分钟 (SFM)

初始条件

材料组	材质	250 (800)	500 (1600)	750 (2400)	1000 (3200)	1250 (4000)	1500 (4800)	1750 (5600)	2000 (6400)	2250 (7200)	2500 (8000)	米/分钟	SFM
N1	KC5410	◀▶										550	1800

### ■ 其它工件材料的推荐切削速度

机械加工性能指数范围70-100内的铜基材料、黄铜基材料和锌基材料

切削速度 — 米/分钟 (SFM)

初始条件



材料组	材质	250 (800)	500 (1600)	750 (2400)	1000 (3200)	米/分钟	SFM
N4	KC5410	◇				275	900
	K313	◇				260	850

尼龙、塑料、橡胶、酚醛塑料、树脂、玻璃纤维、玻璃

切削速度 — 米/分钟 (SFM)

初始条件



材料组	材质	250 (800)	500 (1600)	750 (2400)	1000 (3200)	米/分钟	SFM
N5	KC5410	◇				170	550

碳及石墨复合材料: 镀铜合金、凯夫拉尔纤维、和石墨  
(280-400 HB) (30-43 HRC)

切削速度 — 米/分钟 (SFM)

米/分钟



材料组	材质	250 (800)	500 (1600)	750 (2400)	1000 (3200)	米/分钟	SFM
N6	KC5410	◇				200	650

钛合金, 铸造材料: ASTM 823, 合金 1, 2, 3, 11

切削速度 — 米/分钟 (SFM)

初始条件



材料组	材质	250 (800)	500 (1600)	750 (2400)	1000 (3200)	米/分钟	SFM
N8	KC5410	◇				215	700
	K313	◇				180	600

■ 步骤1 • 选择刀片槽型



负前角刀片

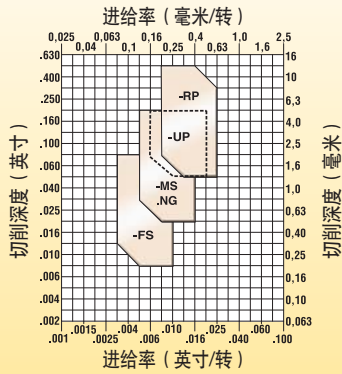

正前角刀片

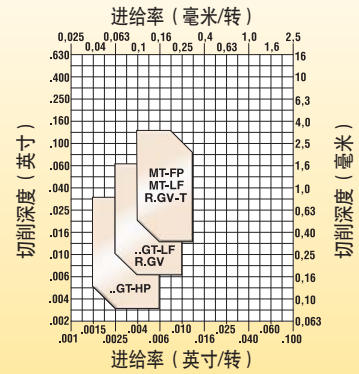

■ 步骤2 • 选择刀片材质

负角刀片槽型

切削条件		-FS	-MS	-UP	-RP
重型断续切削		KCU25	KCU25	KCM35B	KCM25B/ KCM35B
轻微断续切削		KCU10	KCU25	KCM25B	KCM15B
变深切削, 铸造、或锻造表皮		KCU10	KCU10	KCM15B	KCU25
平滑切削、预车削表面		KCU10/K313	KCU10/K313	KCU10	KCU10

正角刀片槽型

切削条件		MT-FP	..GT-HP	MT-LF	..GT-LF
重型断续切削		KCU25	-	KCU25	KCU25
轻微断续切削		KCU25	KCU25	KCU25	KCU25
变深切削, 铸造、或锻造表皮		KCU10/KU10	KCU10	KCU10	KCU10
平滑切削、预车削表面		KCU10/KU10	KCU10/K313	KCU10/K313	KCU10/K313

**步骤3 • 选择切削速度**

铁基及耐热合金 (135–320 HB) (≤34 HRC)

切削速度 – 米/分钟

初始条件

材料组	材质	15	45	75	105	140	170	200	230	260	290	310	350	380	初始条件	
		(50)	(150)	(250)	(350)	(450)	(550)	(650)	(750)	(850)	(950)	(1050)	(1150)	(1250)	米/分钟	SFM
S1	K313/KU10	◇												30	100	
	KCU10	◇												55	180	
	KCU25	◇												40	125	
	KCM15B/KCM15	◇												55	180	
	KCM25B/KCM25/KCM35B/KCM35	◇												40	125	

钴基及耐热合金 (150–425 HB) (≤45 HRC)

切削速度 – 米/分钟 (SFM)

初始条件

材料组	材质	15	45	75	105	140	170	200	230	260	290	310	350	380	初始条件	
		(50)	(150)	(250)	(350)	(450)	(550)	(650)	(750)	(850)	(950)	(1050)	(1150)	(1250)	米/分钟	SFM
S2	K313/KU10	◇												35	110	
	KCU10	◇												60	195	
	KCU25	◇												30	100	
	KCM15B/KCM15	◇												60	195	
	KCM25B/KCM25/KCM35B/KCM35	◇												30	100	

镍基及耐热合金 (140–475 HB) (≤48 HRC)

切削速度 – 米/分钟 (SFM)

初始条件

材料组	材质	15	45	75	105	140	170	200	230	260	290	310	350	380	初始条件	
		(50)	(150)	(250)	(350)	(450)	(550)	(650)	(750)	(850)	(950)	(1050)	(1150)	(1250)	米/分钟	SFM
S3	K313/KU10	◇												40	125	
	KCU10	◇												70	225	
	KCU25	◇												40	125	
	KCM15B/KCM15	◇												70	225	
	KCM25B/KCM25/KCM35B/KCM35	◇												40	125	

钛和钛合金 (110–450 HB) (≤48 HRC)

切削速度 – 米/分钟 (SFM)

初始条件

材料组	材质	15	45	75	105	140	170	200	230	260	290	310	350	380	初始条件	
		(50)	(150)	(250)	(350)	(450)	(550)	(650)	(750)	(850)	(950)	(1050)	(1150)	(1250)	米/分钟	SFM
S4	K313/KU10	◇												45	150	
	KCU10	◇												70	225	
	KCU25	◇												55	175	
	KCM15B/KCM15	◇												70	225	
	KCM25B/KCM25/KCM35B/KCM35	◇												55	175	

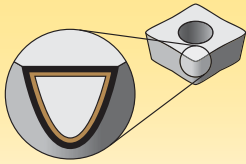

涂层更适合高速加工，并且可用于精加工至轻型粗加工的应用范围。

P	钢
M	不锈钢
K	铸铁
N	非铁金属
S	高温合金
H	硬材料

耐磨性 ←————→ 韧性

无涂层硬质合金材质

涂层	材质说明		05	10	15	20	25	30	35	40	45	
K313	成分：一种硬的，含有较少粘结剂的，WC/Co 非合金细晶粒材质。 应用：在切削钛、铸铁、奥氏体不锈钢、非铁金属、非金属、以及高温合金材料工件时，具有出色的抗刃口磨损性能，以及很高的强度。具有出色的抗热变形和抗切深处破损的性能。晶粒结构的控制非常出色，避免出现微小凹陷和瑕疵，从而具有更长的使用寿命，以及更可靠的性能。	M										
		K										
		N										
		S										
K68	成分：一种硬的，含有较少粘结剂，合金材质的WC/Co细晶粒材质。 应用：K68 材质在对铸铁、奥氏体不锈钢、非铁金属、非金属进行切削；以及在作为 K313 替代材质对极高温合金工件进行切削时，具有出色的抗磨损性能。一种用于非铁金属材料通用加工的材质。	M										
		K										
		N										
		S										

PVD涂层硬质合金刀片

KCS10	成分：一种先进的，采用 PVD AlTiN 涂层的细晶粒碳化钨材质。 应用：KCS10 材质特别用于高温合金材料的高效加工应用。细晶粒碳化钨基体具有出色的韧性和抗变形性能；同时，高级PVD涂层与常规PVD涂层刀具相比，金属切削速度可提高一倍。	P										
		M										
		K										
		N										
		S										
		H										
KCU10	成分：一种先进的PVD复合涂层材质，基体为一种具有强抗变形能力的非合金碳化物。这种经过改良的新型涂层可以提高刃口的稳定性，并可用于多种切削速度和进给量的加工。 应用：KCU10™ 是对多种工件材料进行精加工至一般加工的理想材质，在加工过程中可采用多种切削速度和进给量。在多种钢材料、不锈钢材料、铸铁材料、非铁金属材料、以及超级合金材料的加工中具有卓越的性能；具有更好的刃口韧性，抗切深处磨损，以及更高的切削速度/进给率性能。	P										
		M										
		K										
		N										
		S										
		H										



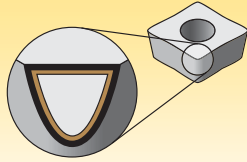

涂层更适合高速加工，并且可用于精加工至轻型粗加工的应用范围。

P	钢
M	不锈钢
K	铸铁
N	非铁金属
S	高温合金
H	硬材料

耐磨性 ←————→ 韧性

PVD 涂层硬质合金刀片

涂层	材质说明		05	10	15	20	25	30	35	40	45
KC025	<p>成分：一种高级 PVD 材质，采用硬质 AlTiN 涂层，以及细晶粒的非合金基体。这种经过改良的新型涂层可以提高刃口的稳定性，并可用于多种切削速度和进给量的加工。</p> <p>应用：KC025™ 材质是用于多种钢材料、不锈钢、高温合金、钛、铁，以及非金属材料通用加工的理想材质；可采用多种切削速度和进给率进行加工，刃口具有更好的韧性，可进行高进给断续切削加工。</p>	P									
		M									
KC5010	<p>成分：一种先进的PVD AlTiN涂层材质，基体为一种具有强抗变形能力的非合金碳化物。</p> <p>应用：KC5010™ 材质适合多种工件材料的精加工和一般加工。在多种钢材料、不锈钢材料、铸铁材料、非金属材料、以及高温合金材料的稳定工况加工中具有卓越的性能。并且在硬化材料和短切屑材料的加工中同样具有很好的性能。</p>	P									
		M									
KC5025	<p>成分：一种高级PVD AlTiN涂层材料，基体为一种具有韧性，超细晶粒的非合金物质。</p> <p>应用：用于对多种钢材料、不锈钢、高温合金、钛、铁，以及非金属材料进行通用加工。切削速度可以从低速到中速，并且可以进行大进给断续切削。</p>	P									
		M									
KC5410	<p>成分：一种 PVD TiB<sub>2</sub> 涂层材料，基体为一种具有强抗变形能力的非合金物质。</p> <p>应用：可以对易加工（亚共晶体&lt;12.2% Si）铝材料、铝合金、以及镁合金材料进行粗加工、半精加工、以及精加工。TiB<sub>2</sub> 涂层比 TiN 和 TiAlN 涂层有更大的硬度，具有非常光滑的表面，可降低表面摩擦力，加速切屑流的流动，并具有卓越的抗磨损性能。避免了积屑瘤的出现，因为这种涂层与铝材料有着极低的结合性。基体为非合金细晶粒材料，具有锋利的刃口、光滑的表面、以及卓越的抗热变形能力和刀刃完整性。周边磨削的刀片在涂层工艺前经过了抛光处理，刃口锋利。压铸成型刀片经过了轻微磨削处理。</p>	P									
		M									



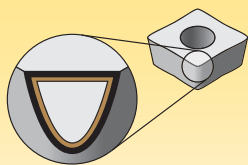

涂层更适合高速加工，并且可用于精加工至轻型粗加工应用范围。

P	钢
M	不锈钢
K	铸铁
N	非铁金属
S	高温合金
H	硬材料

耐磨性 ←————→ 韧性

CVD涂层硬质合金材质

涂层	材质说明		05	10	15	20	25	30	35	40	45
KCP05B	 成分：一种新型，具有很强抗变形能力的高钴含量基质，涂层为专门设计的，具有粘着性能的 MTCVD-TiCN-Al <sub>2</sub> O <sub>3</sub> -TiOCN 材料。 应用：用于对多种钢材料、铁素体、马氏体、PH不锈钢，以及铸铁材料进行精加工至半精加工的应用范围。具有卓越的抗变形性能以及出色的刀片刃口强度。采用先进的涂层去应力处理工艺的新型涂层，具有出色的加工效率，超长并可以预测的刀具寿命，以及卓越的工件表面加工质量。	P									
		K									
<b>beyond DRIVE™</b>											
KCP05	 成分：一种新型，具有很强抗变形能力的高钴含量基质，涂层为专门设计的，具有粘着性能的 MTCVD-TiCN-Al <sub>2</sub> O <sub>3</sub> 材料。 应用：用于对多种钢材料、铁素体、马氏体、PH不锈钢，以及铸铁材料进行精加工至半精加工的应用范围。具有卓越的抗变形性能以及出色的刀片刃口强度。采用先进的涂层去应力处理工艺的新型涂层，具有出色的加工效率，超长并可以预测的刀具寿命，以及卓越的工件表面加工质量。	P									
		K									
<b>beyond</b>											
KCPK05	 成分：一种具有抗变形能力的高钴含量基体材料，采用厚层 MTCVD TiCN-Al <sub>2</sub> O <sub>3</sub> 涂层。 应用：不锈钢和 PH 不锈钢材料的连续和轻微断续车削，具有生产率高特点。这种材质具有更好的刀刃韧性以及高速耐磨损性能，在钢材料加工中具有生产率高特点。独特的基体和涂层组合确保在铸铁材料加工中，以及对抗崩刃性能有较高要求的应用中有理想的性能。	P									
		K									
<b>beyond</b>											
KCP10B	 成分：一种特别设计的高钴硬质合金材质，以及具有出色抗磨损性能的 MTCVD-TiCN-Al <sub>2</sub> O <sub>3</sub> -TiOCN 厚涂层。 应用：用于对多种工件材料，包括钢材料、铁素体、马氏体、PH不锈钢，以及铸铁材料进行精加工至一般加工的应用范围。钴基材料基体在抗变形性能和刀刃韧性之间有着良好的平衡性，厚涂层在高速切削中具有出色的耐磨性和抗月牙洼磨损性。光滑的涂层表面可以避免出现积屑瘤和微崩刃现象，并具有出色的表面精加工性能。	P									
		K									
<b>beyond DRIVE™</b>											
KCP10	 成分：一种特别设计的高钴硬质合金材质，以及具有出色抗磨损性能的 MTCVD-TiCN-Al <sub>2</sub> O <sub>3</sub> 厚涂层。 应用：用于对多种工件材料，包括钢材料、铁素体、马氏体、PH不锈钢，以及铸铁材料进行精加工至一般加工的应用范围。钴基材料基体在抗变形性能和刀刃韧性之间有着良好的平衡性，厚涂层在高速切削中具有出色的耐磨性和抗月牙洼磨损性。光滑的涂层表面可以避免出现积屑瘤和微崩刃现象，并具有出色的表面精加工性能。	P									
		K									
<b>beyond</b>											





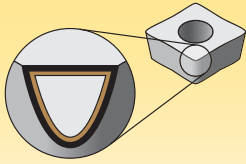

涂层更适合高速加工，并且  
可用于精加工至轻型粗加工  
的应用范围。

P	钢
M	不锈钢
K	铸铁
N	非铁金属
S	高温合金
H	硬材料

耐磨性 ←————→ 韧性

CVD涂层硬质合金材质

涂层		材质说明		05	10	15	20	25	30	35	40	45
KCP40B		成分：一种韧性很好的硬质合金材质，并采用薄层 MTCVD TiCN-Al <sub>2</sub> O <sub>3</sub> -TiOCN 涂层。 应用：用于对碳材料、合金材料、以及不锈钢材料进行重型粗加工。基体与涂层的配合使刀片具有非常出色的韧性，并具有很高的安全操作性；即使在要求最为苛刻的断续切削中也具有很高的金属去除率。	P									
	-		M									
KCP40		成分：一种韧性很好的硬质合金材质，并采用薄层 MTCVD TiCN-Al <sub>2</sub> O <sub>3</sub> 涂层。 应用：用于对碳材料、合金材料、以及不锈钢材料进行重型粗加工。基体与涂层的配合使刀片具有非常出色的韧性，并具有很高的安全操作性；即使在要求最为苛刻的断续切削中也具有很高的金属去除率。	P									
	-		M									
KCK05B		成分：一种厚度适当的 MTCVD TiCN-Al <sub>2</sub> O <sub>3</sub> -TiOCN 复合涂层，基体为一种具有强抗变形能力的硬质合金材料。 应用：用于灰铸铁和球墨铸铁材料的高速切削加工。基体与涂层的结合，以及涂层去应力处理工艺确保刀具具备超长使用寿命的优势，特别适合对具有较高抗拉强度的球墨铸铁和灰铸铁进行切削的加工，以及对工件尺寸一致性、加工可靠性、和刀具寿命有较高要求的加工应用。在连续和变切深加工中都具有卓越的性能。	P									
	-		K									
KCK05		成分：一种厚度适当的 MTCVD TiCN-Al <sub>2</sub> O <sub>3</sub> 复合涂层，基体为一种具有强抗变形能力的硬质合金材料。 应用：用于灰铸铁和球墨铸铁材料的高速切削加工。基体与涂层的结合，以及涂层去应力处理工艺确保刀具具备超长使用寿命的优势，特别适合对具有较高抗拉强度的球墨铸铁和灰铸铁进行切削的加工，以及对工件尺寸一致性、加工可靠性、和刀具寿命有较高要求的加工应用。在连续和变切深加工中都具有卓越的性能。	P									
	-		K									
KCK15B		成分：一种采用 MTCVD TiCN-Al <sub>2</sub> O <sub>3</sub> -TiOCN 材料的多层厚涂层，硬质合金基体是专为铸铁材料加工而设计的。 应用：用于灰铸铁和球墨铸铁材料的高速切削加工，具有一致的切削性能。这种基体允许刀片进行长时间的高速切削，刀片变形量很小。CVD 厚涂层以及涂层去应力处理工艺使刀片具有卓越的耐磨性，确保刀具具有超长的使用寿命。可以用于连续切削和轻微断续切削加工。	P									
	-		K									

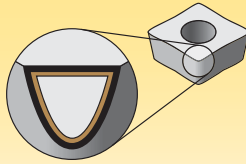

涂层更适合高速加工，并且可用于精加工至轻型粗加工的应用范围。

P	钢
M	不锈钢
K	铸铁
N	非铁金属
S	高温合金
H	硬材料

耐磨性 ←————→ 韧性

CVD涂层硬质合金材质

涂层	材质说明		05	10	15	20	25	30	35	40	45
KCK15	<p>成分：一种采用 MTCVD TiCN-Al<sub>2</sub>O<sub>3</sub> 材料的多层厚涂层，硬质合金基体是专为铸铁材料加工而设计的。</p> <p>应用：用于灰铸铁和球墨铸铁材料的高速切削加工，具有一致的切削性能。这种基体允许刀片进行长时间的高速切削，刀片变形量很小。CVD 厚涂层以及涂层去应力处理工艺使刀片具有卓越的耐磨性，确保刀具具有超长的使用寿命。可以用于连续切削和轻微断续切削加工。</p>	P									
		K									
<b>beyond</b>											
KCK20B	<p>成分：一种经过特别增加韧性处理的 MTCVD-TiCN-Al<sub>2</sub>O<sub>3</sub>-TiOCN 涂层，基体具有很好的耐磨性。</p> <p>应用：增加了涂层的粘着性以及刀刃的强度，是对灰铸铁和球墨铸铁材料进行湿式断续切削的理想材质。这种材质的应用范围广泛，从精加工至粗加工，在对刀具强度和加工可靠性有较高要求的加工中有非常出色的加工效率。</p>	P									
		K									
<b>beyond DRIVE™</b>											
KCK20	<p>成分：一种经过特别增加韧性处理的 MTCVD-TiCN-Al<sub>2</sub>O<sub>3</sub> 涂层，基体具有很好的耐磨性。</p> <p>应用：增加了涂层的粘着性以及刀刃的强度，是对灰铸铁和球墨铸铁材料进行湿式断续切削的理想材质。这种材质的应用范围广泛，从精加工至粗加工，在对刀具强度和加工可靠性有较高要求的加工中有非常出色的加工效率。</p>	P									
		K									
<b>beyond</b>											
KCM15B	<p>成分：一种采用 MTCVD-TiCN-Al<sub>2</sub>O<sub>3</sub> 复合涂层的硬质合金材质。</p> <p>应用：用于对奥氏体不锈钢材料，以及从P20-P25 的多种钢质材料进行高速切削的精加工至一般加工。KCM15B 材质与特有槽型的结合可以避免切深处破损，并且减少毛口的形成。涂层去应力处理可以减少涂层的应力，提高涂层的粘着性能，减少微崩刃和积屑瘤的形成，并提高工件的精加工质量。</p>	P									
		M									
<b>beyond DRIVE™</b>											

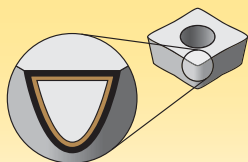

涂层更适合高速加工，并且  
可用于精加工至轻型粗加工  
的应用范围。

P	钢
M	不锈钢
K	铸铁
N	非铁金属
S	高温合金
H	硬材料

耐磨性 ←————→ 韧性

CVD涂层硬质合金材质

涂层	材质说明		05	10	15	20	25	30	35	40	45
KCM15	 成分：一种采用 MTCVD-TiCN-Al <sub>2</sub> O <sub>3</sub> 复合涂层的硬质合金材质。 应用：用于对奥氏体不锈钢材料，以及从P20-P25 的多种钢质材料进行高速切削的精加工至一般加工。KCM15 材质与特有槽型的结合可以避免切深处破损，并且减少毛口的形成。涂层去应力处理可以减少涂层的应力，提高涂层的粘着性能，减少微崩刃和积屑瘤的形成，并提高工件的精加工质量。  	P									
		M									
KCM25B	 成分：一种采用 MTCVD-TiCN-Al <sub>2</sub> O <sub>3</sub> -TiOCN 多层涂层的硬质合金材质。 应用：这种 CVD 涂层材质专门用于对奥氏体不锈钢材料进行中速切削的通用加工。这种材质具有良好的韧性，在不锈钢材料加工中可以避免出现积屑瘤，并具有卓越的抗磨损性能。  	P									
		M									
KCM25	 成分：一种包括 MTCVD TiCN-Al <sub>2</sub> O <sub>3</sub> 材料的 CVD 复合涂层，基体为韧性很好的钴基碳化物材料。 应用：这种 CVD 涂层材质专门用于对奥氏体不锈钢材料进行中速切削的通用加工。这种材质具有良好的韧性，在不锈钢材料加工中可以避免出现积屑瘤，并具有卓越的抗磨损性能。  	P									
		M									
KCM35B	 成分：一种包括 MTCVD TiCN-Al <sub>2</sub> O <sub>3</sub> -TiOCN 材料的复合涂层，基体为一种韧性极强的材料。 应用：用于加工条件极为苛刻的铸造不锈钢材料加工。基体可用于重型断续切削，涂层具有耐磨性，可以延长刀具寿命。经抛光处理的表面可以避免积屑瘤的形成，即使在低速切削过程中也是如此。提供适合大进给大切深的刀片尺寸和槽型。  	P									
		M									
KCM35	 成分：一种包括 MTCVD TiCN-Al <sub>2</sub> O <sub>3</sub> 材料的复合涂层，基体为一种韧性极强的材料。 应用：用于加工条件极为苛刻的铸造不锈钢材料加工。基体可用于重型断续切削，涂层具有耐磨性，可以延长刀具寿命。经抛光处理的表面可以避免积屑瘤的形成，即使在低速切削过程中也是如此。提供适合大进给大切深的刀片尺寸和槽型。  	P									
		M									

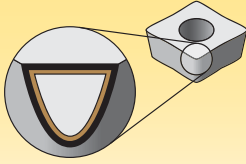

涂层更适合高速加工，并且可用于精加工至轻型粗加工的应用范围。

P	钢
M	不锈钢
K	铸铁
N	非铁金属
S	高温合金
H	硬材料

耐磨性 ←————→ 韧性

PVD涂层金属陶瓷材质

涂层		材质说明		05	10	15	20	25	30	35	40	45
KT315		成分：一种采用 PVD-TiN/TiCN/TiN 复合涂层的金属陶瓷车刀材质。 应用：用于对多种碳材料、合金材料、以及不锈钢材料进行高速切削精加工和一般加工。在铸造件和球墨铸铁材料加工中同样具有出色的加工性能。具有超长并稳定的刀具寿命，并具有卓越的工件精加工性能。	P									
	-		M									
KTP10		成分：一种采用 PVD-TiN/TiCN/TiN 复合涂层的金属陶瓷车刀材质。 应用：用于对多种碳材料、合金材料、以及不锈钢材料进行高速切削精加工和一般加工。在铸造件和球墨铸铁材料加工中同样具有出色的加工性能。具有超长并稳定的刀具寿命，并具有卓越的工件精加工性能。	P									
	-		M									

■ 选择槽型 —  
根据进给率和切削深度

P	钢
M	不锈钢
K	铸铁
N	非铁材料
S	高温合金
H	硬化材料

加工	刀片类型	刀片槽型	仿形加工	进给率 — 毫米											
				0,04	0,063	0,01	0,16	0,25	0,4	0,63	1,0	1,6	2,5	5,0	
				切削深度 — 毫米											
				0,1	0,16	0,25	0,4	0,63	1,0	1,6	2,5	4,0	6,3	10,0	
一精加工	MG-FW														

刀片图解

切削深度范围 —  
适用于各种刀片，选择较小刀片  
用于轻切削加工；选择较大刀片  
用于重切削加工。

进给率范围 —  
为了获得最佳加工效果，  
请选择范围内居中  
60%处的参数值。

断屑槽槽型 —  
刀片刀尖半径处断面

主要工件  
材质分组

P	钢
M	不锈钢
K	铸铁
N	非铁材料
S	高温合金
H	硬化材料

切屑控制槽型设计 —  
例：MG-MP = CNMG-432MP

机械加工 —  
用于设计刀片槽型加工

注：具体材质及槽型选择请参考Kennametal Beyond™ 选择系统，见B8-B21页。



■ 选择槽型 —  
根据进给率和切削深度

P	钢
M	不锈钢
K	铸铁
N	非铁材料
S	高温合金
H	硬化材料

加工	刀片类型	刀片槽型	刀口轮廓	进给率 — 毫米										
				0,04	0,063	0,1	0,16	0,25	0,4	0,63	1,0	1,6	2,5	5,0
				切削深度 — 毫米										
				0,1	0,16	0,25	0,4	0,63	1,0	1,6	2,5	4,0	6,3	10,0
精加工刀具	MG-FP			0,1-0,3										
				0,25-2,5										
	MG-FN			0,1-0,3										
				0,3-2,5										
	MP-K			0,1-0,3										
				0,2-2,5										
半精 刃口锋利	MG-MS			0,12-0,35										
				0,76-5,0										
半精 加工	MG-UP			0,2-0,6										
				1-6,4										



■ 选择槽型 —  
 根据进给率和切削深度

P	钢
M	不锈钢
K	铸铁
N	非铁材料
S	高温合金
H	硬化材料

加工	刀片类型	刀片槽型	刀口轮廓	进给率 — 毫米										
				0,04	0,063	0,01	0,16	0,25	0,4	0,63	1,0	1,6	2,5	5,0
				切削深度 — 毫米										
				0,1	0,16	0,25	0,4	0,63	1,0	1,6	2,5	4,0	6,3	10,0
半精加工	_GP*			0,3-0,5										
				0,5-3,2										
	MG-MP			0,15-0,5										
				0,8-5,1										
	MG-P			0,15-0,5										
				0,75-5,0										
	MG-MN			0,15-0,5										
				0,5-5,1										
	MG-MR			0,15-0,55										
1,5-6,3														
MG-CT 外圆车削			0,13-0,5											
			1,0-3,0											
MG-CT 外向端面加工			0,25-0,5											
			0,25-1,0											
-MS 单面			0,15-0,4											
			0,6-2,3											
MG-UN			0,2-0,5											
			0,8-3,8											

\* 35° 和 55° 槽型为单面刀片。

■ 选择槽型 —  
根据进给率和切削深度

P	钢
M	不锈钢
K	铸铁
N	非铁材料
S	高温合金
H	硬化材料

加工	刀片类型	刀片槽型	刃口轮廓	进给率 — 毫米										
				0,04	0,063	0,01	0,16	0,25	0,4	0,63	1,0	1,6	2,5	5,0
				切削深度 — 毫米										
				0,1	0,16	0,25	0,4	0,63	1,0	1,6	2,5	4,0	6,3	10,0
粗加工	MG-RP			0,2-0,6										
				1,1-6,4										
重载粗加工	MG-RN			0,3-0,63										
				1,1-5,7										
	MG			0,3-0,8										
				1,1-5,7										
	MM-RM 单面			0,3-1,0										
				1,3-12,7										
MM-RP 单面			0,2-1,0											
			1,3-10,0											
MM-RH 单面			0,4-1,3											
			1,3-12,7											
修光精加工	MT-FW			0,08-0,35										
				0,2-1,5										
修光一般精加工	MT-MW			0,12-0,5										
				0,4-3,3										

■ 选择槽型 —  
 根据进给率和切削深度

P	钢
M	不锈钢
K	铸铁
N	非铁材料
S	高温合金
H	硬化材料

加工	刀片类型	刀片槽型	刃口轮廓	进给率 — 毫米											
				0,04	0,063	0,01	0,16	0,25	0,4	0,63	1,0	1,6	2,5	5,0	
				切削深度 — 毫米											
				0,1	0,16	0,25	0,4	0,63	1,0	1,6	2,5	4,0	6,3	10,0	
超精加工	GM 精密磨削			0,05–0,2		0,2–1,0									
	MT-11			0,08–0,25		0,2–1,3									
	.MT-UF			0,05–0,25		0,1–1,3									
精加工	GT-HP 精密磨削			0,2–0,4		0,6–2,3									
	GT-LF 精密磨削			0,2–0,4		0,8–2,3									
	MT-FP			0,063–0,25		0,16–1,6									
	MT-LF			0,2–0,4		0,8–2,3									
半精加工	MT-MP			0,15–0,4		0,4–2,3									
	MT-MF			0,2–0,4		1,1–2,3									

刀具路径	刀片形状	夹持类型	前导	仿形	面铣	插铣	倒角加工	页码	
<b>117,5° 主偏角</b>									
		Kenloc™	•	•	•			B151	
		Kenclamp™	•		•			B150	
<b>107,5° 主偏角</b>									
		螺纹接口型	•	•				B213	
		TNT	•	•		•		B151	
		螺钉锁紧	•	•				B265	
<b>97,5° 主偏角</b>									
		MTS	•		•			—	
<b>95° 主偏角</b>									
		Kenloc	•	•	•			B62	
		Kenclamp	•	•	•			B59	
		Kenlever™	•	•	•			B65	
		螺纹接口型	•	•	•			B180, B193	
		MTS	•	•	•			B358	
		Kenloc	•	•	•			B162	
		Kenclamp	•	•	•			B161	
		Kenlever	•	•	•			B163	
		螺纹接口型	•	•	•			B271	
		MTS	•	•	•			B369	
Wedgelock™	•	•	•			B162			
<b>93° 主偏角</b>									
		Kenloc	•	•				B86	
		Kenclamp	•	•				B85	
		Kenlever	•	•				B87	
		螺纹接口型	•	•				B210	
		MTS	•	•				B360	
		Kenloc	•	•				B151	
		Kenclamp	•	•				B149	
		螺纹接口型	•	•				B267	
			Wedgelock	•	•				B133

刀具路径	刀片形状	夹持类型	前导	仿形	面铣	插铣	倒角加工	页码
<b>90° 主偏角</b>								
		螺纹接口	•	•	•			B179
			螺纹接口	•	•	•		B209
		螺纹接口	•	•	•			B266
			Kenloc	•	•	•	•	
Kenclamp	•		•	•	•		B132	
Kenlever	•		•	•	•		B135	
螺钉锁紧	•		•	•	•		B247	
TNT	•		•	•	•		—	
Wedgelock	•		•	•	•		B133	
<b>85° 主偏角</b>								
		MTS	•		•			B366
<b>75° 主偏角</b>								
		Kenloc	•	•	•			B61
		Kenclamp	•	•	•			B58
		Kenlever	•	•	•			B64
		TNT	•	•	•			—
		螺纹接口型	•	•	•			B180
		MTS	•	•	•			B356
		Kenloc	•	•	•			B108
		Kenclamp	•	•	•			B105
		Kenlever	•	•	•			B111
		螺纹接口型	•	•	•			B233
MTS	•	•	•			B364		
<b>72,5° 主偏角</b>								
		Kenloc	•	•				B152
		Kenclamp	•	•				B150
		螺纹接口型	•	•				B268

刀具 路径	刀片 形状	夹持 类型	车削	仿形	面铣	插铣	倒角加工	页码	
<b>70° 主偏角</b>									
		Kenloc™	•	•				—	
<b>63° 主偏角</b>									
		Kenloc	•	•				B85	
<b>62,5° 主偏角</b>									
		Kenloc	•	•	•			B86	
		Kenlever	•	•	•			B88	
		螺纹接口	•	•				B211	
<b>60° 主偏角</b>									
		Kenloc	•	•	•			B133	
<b>50° 主偏角</b>									
		Kenloc	•	•	•			B63	
<b>45° 主偏角</b>									
		Kenloc	•	•	•			B60	
		Kendex™	•	•	•			B66	
		螺纹接口	•	•	•			B192	
			Kenloc	•	•	•			B109
			Kenclamp	•	•	•			B105
			Kenlever™	•	•	•			B111
		Kendex	•	•	•			—	
		螺纹接口	•	•	•			B233	
		MTS	•	•	•			B213	
		Kenlever	•	•	•			B86	
		Kenloc	•	•	•			B95	
		Kenclamp	•	•	•			—	
Fix-Perfect™		•	•	•			—		
螺纹接口		•	•	•			B227		
MTS	•	•	•			B365			

夹持类型

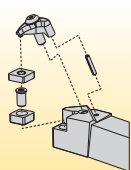

**Kenclamp™ 型**

- 应用 Kenloc™ 负角类型刀片。
- 独特的夹持设计，确保夹持系统具有良好的刚性。
- 确保刀片的重复精度和定位精度。
- 减少振刀，延长刀具寿命。

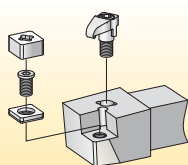

**MTS 型模块化刀具系统**

- 在车削和仿形加工中，具有良好刚性的陶瓷刀片夹持系统。
- 采用标准刀片尺寸 - 80°、75°、55°、方形、三角形。
- 该夹持系统具有更大的灵活性，可以应用选配件对标准型 Kendex™ 和 Kenloc 刀片进行夹持。

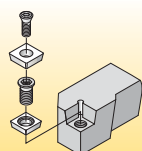

**螺纹接口型**

- 使用螺钉对螺纹接口型刀片进行上部夹持。

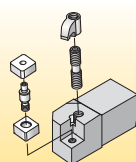

**Kenloc 型**

- 应用 Kenloc™ 负角类型刀片。
- 锁销及上部夹板确保该夹持系统具有良好的刚性。
- 可以使用多种型号的刀片产品。
- 可以在使用夹具或不使用夹具的情况下应用刀具。

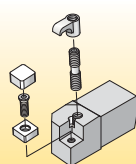

**Kendex 型**

- 应用 Kendex 刀片。
- 陶瓷刀片可以选用断屑器。
- 可以使用多种型号的刀片产品。

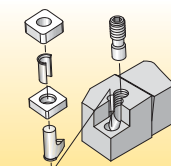

**Kenlever™ 型**

- 在车削和仿形加工中，具有良好刚性的陶瓷刀片夹持系统。
- 可选配件可以用于 Kendex 或 Kenloc 刀片。

## 如何使用目录编号？

产品目录中的每一个字符都表示产品的一个具体特征。利用下面的栏框以及对应的图形，可以容易地找到适用的刀具参数值。

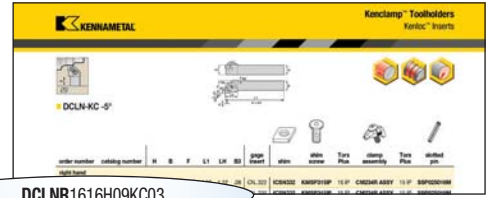

DCLNR1616H09KC03

D	C	L	N	R	
刀片 夹持方法	刀片形状	刀具类型或主偏角	刀片 后角	刀具方向	其它信息
<p>Kenclamp™</p> <p>Kenloc™</p> <p>Kendex™</p> <p>Top Notch™ Profiling</p> <p>螺纹接口型</p> <p>Kenlever™</p>	<p>A </p> <p>B </p> <p>C </p> <p>D </p> <p>E </p> <p>H </p> <p>K </p> <p>L </p> <p>M </p> <p>O </p> <p>P </p> <p>R </p> <p>S </p> <p>T </p> <p>V </p> <p>W </p>	<p>A  L </p> <p>B  M </p> <p>C  P </p> <p>D  Q </p> <p>E  R </p> <p>F  S </p> <p>G  U </p> <p>H  V </p> <p>J  Y </p> <p>K </p>	<p>N 0° </p> <p>B 5° </p> <p>C 11° </p> <p>P 11° </p> <p>D 15° </p> <p>E 20° </p> <p>F 25° </p>	<p>R = 右手</p> <p>L = 左手</p> <p>N = 中性</p>	<p>C = 用于陶瓷刀片的深孔刀座</p> <p>S = 带定位壁的单孔刀座</p> <p>F = 直柄刀杆, 无偏置调整</p>

这份指南使用非常方便，可以快速找到客户需要查找的产品。

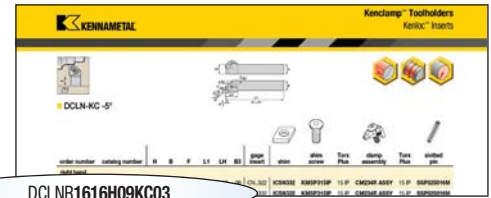

DCLNR1616H09KC03

**16**

刀柄尺寸

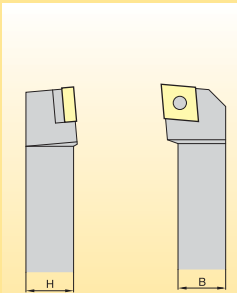

第七位和第八位组成一个非常重要的两位数字，表示刀柄的横截面。

- 如果表示宽度“B”或高度“H”的数字为个位数字，前面一位应加“0”。

举例：8,0mm = 08

**16**

**H**

刀杆长度

L1	ISO
32	A
40	B
50	C
60	D
70	E
80	F
90	G
100	H
110	J
125	K
140	L
150	M
160	N
170	P
180	Q
200	R
250	S
300	T
350	U
400	V
450	W
500	Y
特殊设计	X

**09**

刀片尺寸

**KC**

其它信息

**KC** =  
Kenclamp™

**H4** =  
Wedglock™ 夹持系统

**M** =  
用于陶瓷刀片和 PcBN 刀片的 MTS 夹持装置

**03**

刀片厚度  
(可选)

**04** = 4,76mm  
**06** = 6,35mm

切削刃长度 L 10

<b>H</b>	六角形 120°		<b>C</b>	菱形 80°	
<b>O</b>	八角形 135°		<b>D</b>	55°	
<b>P</b>	五角形 108°		<b>E</b>	75°	
<b>S</b>	正方形 90°		<b>M</b>	86°	
<b>T</b>	三角形 60°		<b>V</b>	35°	
<b>R</b>	圆形 —		<b>W</b>	三角形 80° 带有加大圆角	
			<b>L</b>	正方形 90°	
			<b>A</b>	平行四边形 85°	
			<b>B</b>	82°	
			<b>K</b>	55°	

刀具 路径	刀片 形状	夹持 类型	镗孔	反镗	仿形	页码	
<b>■ 117,5° 主偏角</b>							
		<b>Kenclamp™</b>	•	•		B89	
<b>■ 107,5° 主偏角</b>							
		<b>Kenclamp</b>	•	•	•	B89	
		螺纹接口	•	•		B212, B217	
		螺纹接口	•	•	•	B268	
<b>■ 95° 主偏角</b>							
		<b>Kenloc™</b>	•		•	B67	
		<b>Kenclamp™</b>	•		•	B66	
		螺纹接口	•		•	•	B182, B196
		<b>Kenlever™</b>	•		•	•	B68
	<b>MTS</b>	•		•	•	B372	
		<b>MTS</b>	•		•	—	
		螺纹接口	•		•	B250	
		<b>Kenloc</b>	•			B164	
		<b>Kenclamp</b>	•		•	B163	
		<b>Kenlever</b>	•		•	B165	
		螺纹接口	•		•	•	B271
		<b>MTS</b>	•		•	B374	
<b>■ 93° 主偏角</b>							
		<b>Kenloc</b>	•	•	•	B90	
		<b>Kenclamp</b>	•	•	•	B90	
		螺纹接口	•		•	•	B212, B217
		<b>MTS</b>	•		•	•	—
		<b>Kenloc</b>	•		•	B153	
		<b>Kenclamp</b>	•	•		B152	
		螺纹接口	•	•	•	B269	
		<b>Kendex™</b>	•		•	B371	
		螺纹接口	•		•	B272	

刀具 路径	刀片 形状	夹持 类型	镗孔	反镗	仿形	页码
<b>■ 90° 主偏角</b>						
		螺纹接口	•		•	B182, B194
		<b>Kenloc</b>	•			B137
		<b>Kenclamp</b>	•		•	B137
		<b>Kenlever</b>	•		•	B138
		<b>Kendex</b>	•		•	—
		螺纹接口	•			B248, B257
<b>■ 75° 主偏角</b>						
		螺纹接口	•			B195
		<b>Kenloc</b>	•			B114
		<b>Kenclamp</b>	•			B113
		<b>Kenlever</b>	•			B114
		<b>Kendex</b>	•			—
		螺纹接口	•			B233
			<b>MTS</b>	•		
	<b>Kendex</b>		•			—
<b>■ 60° 主偏角</b>						
		螺纹接口	•		•	—
<b>■ 45° 主偏角</b>						
		<b>MTS</b>	•			B373



## 夹持类型

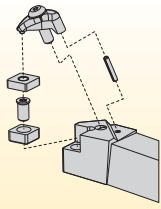

### Kenclamp™ 型

- 应用 Kenloc™ 负角类型刀片。
- 独特的夹持设计，确保夹持系统具有良好的刚性。
- 确保刀片的重复精度和定位精度。
- 减少振刀，延长刀具寿命。

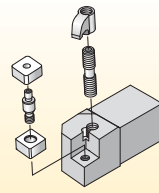

### Kenloc™ 型

- 应用 Kenloc™ 负角类型刀片。
- 锁销及上部夹板确保该夹持系统具有良好的刚性。
- 可以使用多种型号的刀片产品。
- 可以在使用夹具或不使用夹具的情况下应用刀具。

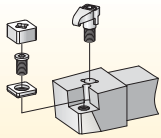

### MTS 型

- 在车削和仿形加工中，具有良好刚性的陶瓷刀片夹持系统。
- 采用标准刀片尺寸 - 80°、75°、55°、方形、三角形。
- 该夹持系统具有更大的灵活性，可以应用选配备件对标准型 Kendex™ 和 Kenloc 刀片进行夹持。

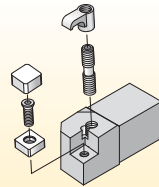

### Kendex™ 型

- 应用 Kendex 刀片。
- 陶瓷刀片可以选用断屑器。
- 可以使用多种型号的刀片产品。

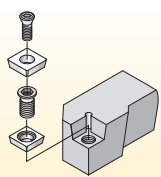

### 螺纹接口型

- 使用螺钉对螺纹接口型刀片进行上部夹持。

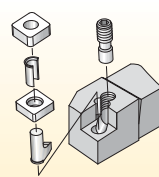









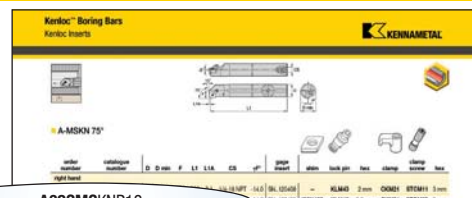

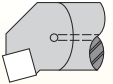
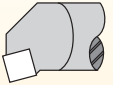
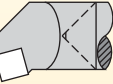
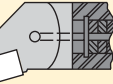
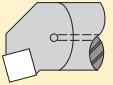
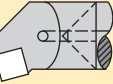
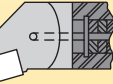
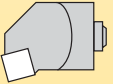
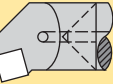

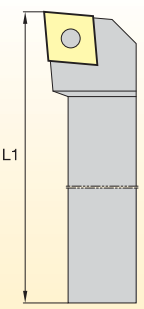
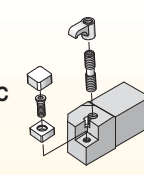
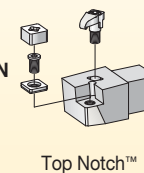
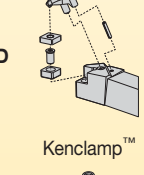
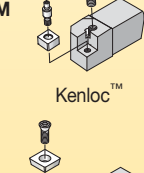







### Kenlever™ 型

- 在车削和仿形加工中，具有良好刚性的陶瓷刀片夹持系统。
- 可选配件可以用于 Kendex 或 Kenloc 刀片。

## 如何使用目录编号？

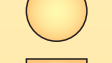
产品目录中的每一个字符都表示产品的一个具体特征。利用下面的栏框以及对应的图形，可以容易地找到适用的刀具参数值。

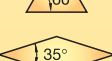

A	32	S	M	S																																																																					
镗杆类型	镗杆直径	镗杆长度**	刀片 夹持方法	刀片形状																																																																					
<p><b>A</b>  带内冷的钢镗杆</p> <p><b>S</b>  不带内冷的钢镗杆</p> <p><b>C</b>  硬质合金镗杆</p> <p><b>D</b>  带有内冷的减震镗杆</p> <p><b>D</b>  带内冷的可调谐镗杆</p> <p><b>E</b>  带内冷的硬质合金镗杆</p> <p><b>B</b>  减震装置</p> <p><b>H</b>  互换式镗头</p> <p><b>L</b>  带内冷的重金属镗杆</p>	<p> 公制： 两位数的数字表示镗杆直径，单位为毫米。如果直径为个位数字，前一位应当加“0”。 例如：8毫米 = 08</p>	<p> <b>L1</b>      <b>ISO</b></p> <table border="0"> <tr><td>32</td><td>=</td><td>A</td></tr> <tr><td>40</td><td>=</td><td>B</td></tr> <tr><td>50</td><td>=</td><td>C</td></tr> <tr><td>60</td><td>=</td><td>D</td></tr> <tr><td>70</td><td>=</td><td>E</td></tr> <tr><td>80</td><td>=</td><td>F</td></tr> <tr><td>90</td><td>=</td><td>G</td></tr> <tr><td>100</td><td>=</td><td>H</td></tr> <tr><td>110</td><td>=</td><td>J</td></tr> <tr><td>125</td><td>=</td><td>K</td></tr> <tr><td>140</td><td>=</td><td>L</td></tr> <tr><td>150</td><td>=</td><td>M</td></tr> <tr><td>160</td><td>=</td><td>N</td></tr> <tr><td>170</td><td>=</td><td>P</td></tr> <tr><td>180</td><td>=</td><td>Q</td></tr> <tr><td>200</td><td>=</td><td>R</td></tr> <tr><td>250</td><td>=</td><td>S</td></tr> <tr><td>300</td><td>=</td><td>T</td></tr> <tr><td>350</td><td>=</td><td>U</td></tr> <tr><td>400</td><td>=</td><td>V</td></tr> <tr><td>450</td><td>=</td><td>W</td></tr> <tr><td>500</td><td>=</td><td>Y</td></tr> <tr><td>非标长度=</td><td></td><td>X</td></tr> </table>	32	=	A	40	=	B	50	=	C	60	=	D	70	=	E	80	=	F	90	=	G	100	=	H	110	=	J	125	=	K	140	=	L	150	=	M	160	=	N	170	=	P	180	=	Q	200	=	R	250	=	S	300	=	T	350	=	U	400	=	V	450	=	W	500	=	Y	非标长度=		X	<p><b>C</b>  Kindex™</p> <p><b>N</b>  Top Notch™ 仿形加工刀具</p> <p><b>D</b>  Kenclamp™</p> <p><b>M</b>  Kenloc™</p> <p><b>S</b>  螺纹接口型</p> <p><b>P</b>  Kenlever™</p>	<p><b>A</b>  85°</p> <p><b>B</b>  82°</p> <p><b>C</b>  80°</p> <p><b>D</b>  55°</p> <p><b>E</b>  75°</p> <p><b>H</b>  120°</p> <p><b>K</b>  55°</p> <p><b>L</b>  90°</p> <p><b>M</b>  86°</p> <p><b>O</b>  135°</p> <p><b>P</b>  108°</p> <p><b>R</b>  90°</p> <p><b>S</b>  90°</p> <p><b>T</b>  60°</p> <p><b>V</b>  35°</p> <p><b>W</b>  80°</p>
32	=	A																																																																							
40	=	B																																																																							
50	=	C																																																																							
60	=	D																																																																							
70	=	E																																																																							
80	=	F																																																																							
90	=	G																																																																							
100	=	H																																																																							
110	=	J																																																																							
125	=	K																																																																							
140	=	L																																																																							
150	=	M																																																																							
160	=	N																																																																							
170	=	P																																																																							
180	=	Q																																																																							
200	=	R																																																																							
250	=	S																																																																							
300	=	T																																																																							
350	=	U																																																																							
400	=	V																																																																							
450	=	W																																																																							
500	=	Y																																																																							
非标长度=		X																																																																							

这份指南使用非常方便，可以快速找到客户需要查找的产品。

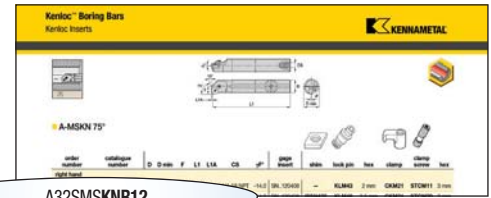

A32SMSKNR12

K	N	R	12	其它信息
镗杆类型或主偏角	刀片 后角	刀具方向	刀片尺寸 刃口 长度 L10	其它信息
<p>E </p> <p>F </p> <p>K </p> <p>L </p> <p>(E型刀片)</p> <p>L </p> <p>P </p> <p>Q </p> <p>S </p> <p>U </p> <p>X </p>	<p>N 0° </p> <p>B 5° </p> <p>C 7° </p> <p>P 11° </p> <p>D 15° </p> <p>E 20° </p> <p>F 25° </p>	<p>R =</p> <p>右手镗杆</p> <p></p> <p>R</p> <p>L =</p> <p>左手镗杆</p> <p></p> <p>L</p>	<p>H </p> <p>O </p> <p>P </p> <p>S </p> <p>T </p> <p>CDE M V </p> <p>W </p> <p>L </p> <p>A B K </p> <p>R </p>	<p>M...=</p> <p>用于陶瓷刀片和 PcBN 刀片的 TNT/MTS 夹 持装置</p> <p>D =</p> <p>双刀座</p> <p>AP5 =</p> <p>轴向正前角</p> <p>KC =</p> <p>Kenclamp™</p> <p>+ =</p> <p>刀片厚度</p>

## 如何使用目录编号？

产品目录中的每一个字符都表示产品的一个具体特征。利用下面的栏框以及对应的图形，可以容易地找到适用的刀具参数值。

Kenloc™ Cartridges Kenloc Inserts		KENNAMETAL	
<b>MCLN 90°</b>			
Part Number	Part Name	Material	Grade
MCLNR12CA12	12mm Carbide Insert	CBN	CBN
Part Number	Part Name	Material	Grade
MCLNR12CA12	12mm Carbide Insert	CBN	CBN

MCLNR12CA12

M	C	L	N	R
锁紧形式	刀片形状	刀具类型或主偏角	刀片 后角	刀具方向

这份指南使用非常方便，可以快速找到客户需要查找的产品。

Kenloc™ Cartridges Kenloc Inserts									
Order Number	Subgroup Number	D (mm)	F	L1	SP	SP	SP	SP	SP
MCLN 95									
12	C	12	30.3	36	-0.3	-1.0			DN 12M40C01.402
			30	30	-0.2	-0.8			DN 12M40C01.402

MCLNR12CA12

<p><b>12</b></p> <p>刀夹尺寸</p> <p>H1 = 刀夹切削刃高度，单位为毫米</p>	<p><b>C</b></p> <p>刀夹的识别代码</p> <p>C = 刀夹</p>	<p><b>A</b></p> <p>刀夹的安装设计</p> <p>A = 角度精度符合 ISO 5611 标准</p>	<p><b>12</b></p> <p>刀片尺寸</p> <p>切削刃长度 D</p> <p>C </p> <p>D </p> <p>R </p> <p>S </p> <p>T </p> <p>W </p>
--	--	--	---

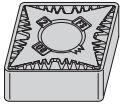

- 首选
- 备选

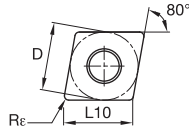

■ CNGG-FS

目录编号	D	L10	Re	KCP05B	KCP05	KCP10B	KCP10	KCP25B	KCP25	KCP30B	KCP30	KCP40B	KCP40	KCK05B	KCK05	KCK15B	KCK15	KCK20B	KCK20	KCM15B	KCM15	KCM25B	KCM25	KCM35B	KCM35	KCPK05	K313	K68	KCU10	KCU25	KC5010	KC5025	KC5410	KT315
CNGG120401FS	12,70	12,90	0,1	-	-	-	-	-	-	-	-	-	-	-	-	-	-	-	-	-	-	-	-	-	-	-	-	-	-	-	-	-	-	-
CNGG120402FS	12,70	12,90	0,2	-	-	-	-	-	-	-	-	-	-	-	-	-	-	-	-	-	-	-	-	-	-	-	-	-	-	-	-	-	-	-
CNGG120404FS	12,70	12,90	0,4	-	-	-	-	-	-	-	-	-	-	-	-	-	-	-	-	-	-	-	-	-	-	-	-	-	-	-	-	-	-	-
CNGG120408FS	12,70	12,90	0,8	-	-	-	-	-	-	-	-	-	-	-	-	-	-	-	-	-	-	-	-	-	-	-	-	-	-	-	-	-	-	-

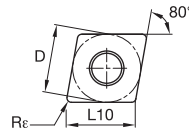
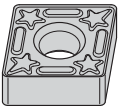

■ CNGG-LF

目录编号	D	L10	Re	KCP05B	KCP05	KCP10B	KCP10	KCP25B	KCP25	KCP30B	KCP30	KCP40B	KCP40	KCK05B	KCK05	KCK15B	KCK15	KCK20B	KCK20	KCM15B	KCM15	KCM25B	KCM25	KCM35B	KCM35	KCPK05	K313	K68	KCU10	KCU25	KC5010	KC5025	KC5410	KT315
CNGG120401LF	12,70	12,90	0,1	-	-	-	-	-	-	-	-	-	-	-	-	-	-	-	-	-	-	-	-	-	-	-	-	-	-	-	-	-	-	-
CNGG120402LF	12,70	12,90	0,2	-	-	-	-	-	-	-	-	-	-	-	-	-	-	-	-	-	-	-	-	-	-	-	-	-	-	-	-	-	-	-
CNGG120404LF	12,70	12,90	0,4	-	-	-	-	-	-	-	-	-	-	-	-	-	-	-	-	-	-	-	-	-	-	-	-	-	-	-	-	-	-	-
CNGG120408LF	12,70	12,90	0,8	-	-	-	-	-	-	-	-	-	-	-	-	-	-	-	-	-	-	-	-	-	-	-	-	-	-	-	-	-	-	-
CNGG120412LF	12,70	12,90	1,2	-	-	-	-	-	-	-	-	-	-	-	-	-	-	-	-	-	-	-	-	-	-	-	-	-	-	-	-	-	-	-

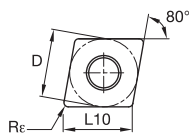
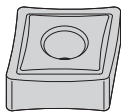

■ CNGP

目录编号	D	L10	Re	KCP05B	KCP05	KCP10B	KCP10	KCP25B	KCP25	KCP30B	KCP30	KCP40B	KCP40	KCK05B	KCK05	KCK15B	KCK15	KCK20B	KCK20	KCM15B	KCM15	KCM25B	KCM25	KCM35B	KCM35	KCPK05	K313	K68	KCU10	KCU25	KC5010	KC5025	KC5410	KT315
CNGP120401	12,70	12,90	0,1	-	-	-	-	-	-	-	-	-	-	-	-	-	-	-	-	-	-	-	-	-	-	-	-	-	-	-	-	-	-	-
CNGP120402	12,70	12,90	0,2	-	-	-	-	-	-	-	-	-	-	-	-	-	-	-	-	-	-	-	-	-	-	-	-	-	-	-	-	-	-	-
CNGP120404	12,70	12,90	0,4	-	-	-	-	-	-	-	-	-	-	-	-	-	-	-	-	-	-	-	-	-	-	-	-	-	-	-	-	-	-	-
CNGP120408	12,70	12,90	0,8	-	-	-	-	-	-	-	-	-	-	-	-	-	-	-	-	-	-	-	-	-	-	-	-	-	-	-	-	-	-	-
CNGP120412	12,70	12,90	1,2	-	-	-	-	-	-	-	-	-	-	-	-	-	-	-	-	-	-	-	-	-	-	-	-	-	-	-	-	-	-	-
CNGP120416	12,70	12,90	1,6	-	-	-	-	-	-	-	-	-	-	-	-	-	-	-	-	-	-	-	-	-	-	-	-	-	-	-	-	-	-	-

注：用于 P 型夹持装置的可转位刀片。



● 首选  
○ 备选

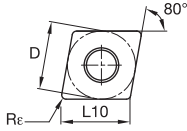
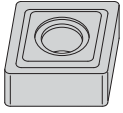

■ CNMG-33

目录编号	D	L10	Re	KCP05B	KCP05	KCP10B	KCP10	KCP25B	KCP25	KCP30B	KCP30	KCP40B	KCP40	KCK05B	KCK05	KCK15B	KCK15	KCK20B	KCK20	KCM15B	KCM15	KCM25B	KCM25	KCM35B	KCM35	KCPK05	K313	K68	KCU10	KCU25	KC5010	KC5025	KC5410	KT315
CNMG12040833	12,70	12,90	0,8	-	-	-	-	-	-	-	-	-	-	-	-	-	-	-	-	-	-	-	-	-	-	-	-	-	-	-	-	-	-	●

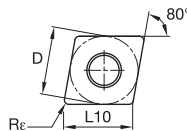
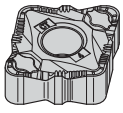

■ CNMG-CT

目录编号	D	L10	Re	KCP05B	KCP05	KCP10B	KCP10	KCP25B	KCP25	KCP30B	KCP30	KCP40B	KCP40	KCK05B	KCK05	KCK15B	KCK15	KCK20B	KCK20	KCM15B	KCM15	KCM25B	KCM25	KCM35B	KCM35	KCPK05	K313	K68	KCU10	KCU25	KC5010	KC5025	KC5410	KT315
CNMG120408CT	12,70	12,90	0,8	-	●	-	-	-	-	-	-	-	-	-	-	-	-	-	-	-	-	-	-	-	-	-	-	-	-	-	-	-	-	-
CNMG120412CT	12,70	12,90	1,2	-	-	●	-	●	●	-	-	-	-	-	-	-	-	-	-	-	-	-	-	-	-	-	-	-	-	-	-	-	-	-
CNMG120416CT	12,70	12,90	1,6	-	-	-	●	-	-	-	-	-	-	-	-	-	-	-	-	-	-	-	-	-	-	-	-	-	-	-	-	-	-	-

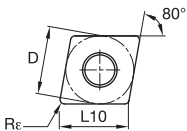
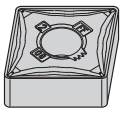

■ CNMG-FF

目录编号	D	L10	Re	KCP05B	KCP05	KCP10B	KCP10	KCP25B	KCP25	KCP30B	KCP30	KCP40B	KCP40	KCK05B	KCK05	KCK15B	KCK15	KCK20B	KCK20	KCM15B	KCM15	KCM25B	KCM25	KCM35B	KCM35	KCPK05	K313	K68	KCU10	KCU25	KC5010	KC5025	KC5410	KT315
CNMG090304FF	9,53	9,67	0,4	-	-	-	-	-	-	-	-	-	-	-	-	-	-	-	-	-	-	-	-	-	-	-	-	-	-	-	-	-	-	-
CNMG090308FF	9,53	9,67	0,8	-	-	-	-	-	-	-	-	-	-	-	-	-	-	-	-	-	-	-	-	-	-	-	-	-	-	-	-	-	-	-
CNMG120404FF	12,70	12,90	0,4	-	●	-	-	-	-	-	-	-	-	-	-	-	-	-	-	-	-	-	-	-	-	-	-	-	-	-	-	-	-	-
CNMG120408FF	12,70	12,90	0,8	-	●	-	-	-	-	-	-	-	-	-	-	-	-	-	-	-	●	-	-	-	-	-	-	-	-	-	-	-	-	-





● 首选  
○ 备选

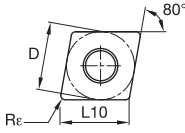
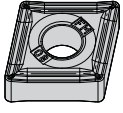

■ CNMG-FM

目录编号	D	L10	Re	KCP05B	KCP05	KCP10B	KCP10	KCP25B	KCP25	KCP30B	KCP30	KCP40B	KCP40	KCK05B	KCK05	KCK15B	KCK15	KCK20B	KCK20	KCM15B	KCM15	KCM25B	KCM25	KCM35B	KCM35	KCPK05	K313	K68	KCU10	KCU25	KC5010	KC5025	KC5410	KT315
CNMG120412FM	12,70	12,90	1,2	-	-	●	-	●	-	-	-	-	-	-	-	-	-	-	-	-	-	-	-	-	-	-	-	-	-	-	-	-	-	-

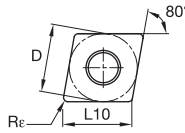

■ CNMG-LF

目录编号	D	L10	Re	KCP05B	KCP05	KCP10B	KCP10	KCP25B	KCP25	KCP30B	KCP30	KCP40B	KCP40	KCK05B	KCK05	KCK15B	KCK15	KCK20B	KCK20	KCM15B	KCM15	KCM25B	KCM25	KCM35B	KCM35	KCPK05	K313	K68	KCU10	KCU25	KC5010	KC5025	KC5410	KT315	
CNMG120402LF	12,70	12,90	0,2	-	-	-	-	-	-	-	-	-	-	-	-	-	-	-	-	-	-	-	-	-	-	-	-	-	-	-	-	-	-	-	
CNMG120404LF	12,70	12,90	0,4	-	-	-	-	●	-	-	-	-	-	-	-	-	-	-	-	-	-	-	-	-	-	-	-	-	-	-	-	-	-	-	
CNMG120408LF	12,70	12,90	0,8	-	-	-	-	●	-	-	-	-	-	-	-	-	-	-	-	-	-	-	-	-	-	-	-	-	-	-	-	-	-	-	-

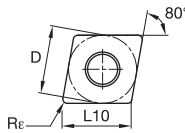
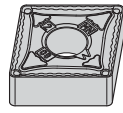

■ CNMG-MN

目录编号	D	L10	Re	KCP05B	KCP05	KCP10B	KCP10	KCP25B	KCP25	KCP30B	KCP30	KCP40B	KCP40	KCK05B	KCK05	KCK15B	KCK15	KCK20B	KCK20	KCM15B	KCM15	KCM25B	KCM25	KCM35B	KCM35	KCPK05	K313	K68	KCU10	KCU25	KC5010	KC5025	KC5410	KT315	
CNMG090304MN	9,53	9,67	0,4	-	-	-	-	●	●	-	-	-	-	-	-	-	-	-	-	-	-	-	-	-	-	-	-	-	-	-	-	-	-	-	
CNMG090308MN	9,53	9,67	0,8	-	-	-	●	●	●	-	-	-	-	-	-	-	-	-	-	-	-	-	-	-	-	-	-	-	-	-	-	-	-	-	-
CNMG090312MN	9,53	9,67	1,2	-	-	-	-	-	●	-	-	-	-	-	-	-	-	-	-	-	-	-	-	-	-	-	-	-	-	-	-	-	-	-	-
CNMG120404MN	12,70	12,90	0,4	-	-	-	●	●	●	-	-	-	-	-	-	-	-	-	-	-	-	-	-	-	-	-	-	-	-	-	-	-	-	-	-
CNMG120408MN	12,70	12,90	0,8	●	●	●	●	●	●	●	-	-	-	-	-	-	-	-	-	-	-	-	-	-	-	-	-	-	-	-	-	-	-	-	-
CNMG120412MN	12,70	12,90	1,2	-	●	●	●	●	●	●	-	-	-	-	-	-	-	-	-	-	-	-	-	-	-	-	-	-	-	-	-	-	-	-	-
CNMG120416MN	12,70	12,90	1,6	-	-	●	●	●	●	●	-	-	-	-	-	-	-	-	-	-	-	-	-	-	-	-	-	-	-	-	-	-	-	-	-
CNMG160608MN	15,88	16,12	0,8	-	-	●	●	●	●	●	-	-	-	-	-	-	-	-	-	-	-	-	-	-	-	-	-	-	-	-	-	-	-	-	-
CNMG160612MN	15,88	16,12	1,2	-	-	●	●	●	●	●	-	-	-	-	-	-	-	-	-	-	-	-	-	-	-	-	-	-	-	-	-	-	-	-	-
CNMG160616MN	15,88	16,12	1,6	-	-	●	●	●	●	●	-	-	-	-	-	-	-	-	-	-	-	-	-	-	-	-	-	-	-	-	-	-	-	-	-
CNMG190608MN	19,05	19,34	0,8	-	-	-	●	●	●	●	-	-	-	-	-	-	-	-	-	-	-	-	-	-	-	-	-	-	-	-	-	-	-	-	-
CNMG190612MN	19,05	19,34	1,2	-	-	-	●	●	●	●	-	-	-	-	-	-	-	-	-	-	-	-	-	-	-	-	-	-	-	-	-	-	-	-	-
CNMG190616MN	19,05	19,34	1,6	-	-	●	●	●	●	●	-	-	-	-	-	-	-	-	-	-	-	-	-	-	-	-	-	-	-	-	-	-	-	-	-
CNMG190624MN	19,05	19,34	2,4	-	-	-	-	●	●	●	-	-	-	-	-	-	-	-	-	-	-	-	-	-	-	-	-	-	-	-	-	-	-	-	-

● 首选  
○ 备选

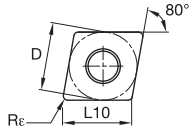
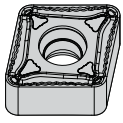

■ CNMU-MN

目录编号	D	L10	Rε
CNMG120612MN	12,70	12,90	1,2
CNMG120616MN	12,70	12,90	1,6

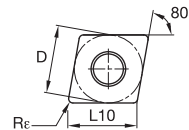
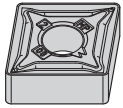

■ CNMG-MP

目录编号	D	L10	Rε
CNMG090308MP	9,53	9,67	0,8
CNMG120404MP	12,70	12,90	0,4
CNMG120408MP	12,70	12,90	0,8
CNMG120412MP	12,70	12,90	1,2
CNMG120416MP	12,70	12,90	1,6
CNMG160608MP	15,88	16,12	0,8
CNMG160612MP	15,88	16,12	1,2
CNMG160616MP	15,88	16,12	1,6
CNMG190608MP	19,05	19,34	0,8
CNMG190612MP	19,05	19,34	1,2
CNMG190616MP	19,05	19,34	1,6

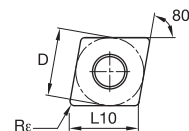
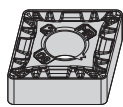

■ CNMG-MR

目录编号	D	L10	Rε
CNMG120404MR	12,70	12,90	0,4
CNMG120408MR	12,70	12,90	0,8
CNMG120412MR	12,70	12,90	1,2
CNMG120416MR	12,70	12,90	1,6
CNMG160608MR	15,88	16,12	0,8
CNMG160612MR	15,88	16,12	1,2
CNMG160616MR	15,88	16,12	1,6
CNMG190612MR	19,05	19,34	1,2
CNMG190616MR	19,05	19,34	1,6

P	M	K	N	S	H	KCP05B	KCP05	KCP10B	KCP10	KCP25B	KCP25	KCP30B	KCP30	KCP40B	KCP40	KCK05B	KCK05	KCK15B	KCK15	KCK20B	KCK20	KCM15B	KCM15	KCM25B	KCM25	KCM35B	KCM35	KCPK05	K313	K68	KCU10	KCU25	KC5010	KC5025	KC5410	KT315		
●	●	○	○	○	○	●	-	-	-	-	-	-	-	-	-	-	-	-	-	-	-	-	-	-	-	-	-	-	-	-	-	-	-	-	-	-	-	-
-	-	-	-	-	-	-	-	-	-	●	-	-	-	-	-	-	-	-	-	-	-	-	-	-	-	-	-	-	-	-	-	-	-	-	-	-	-	-



● 首选  
○ 备选

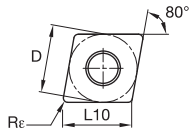
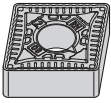

■ CNMG-RN

目录编号	D	L10	Re	KCP05B	KCP05	KCP10B	KCP10	KCP25B	KCP25	KCP30B	KCP30	KCP40B	KCP40	KCK05B	KCK05	KGK15B	KGK15	KCK20B	KCK20	KCM15B	KCM15	KCM25B	KCM25	KCM35B	KCM35	KCPK05	K313	K68	KCU10	KCU25	KC5010	KC5025	KC5410	KT315
CNMG120408RN	12,70	12,90	0,8	-	●	-	-	-	-	-	-	-	-	-	-	-	-	-	-	-	-	-	-	-	-	-	-	-	-	-	-	-	-	-
CNMG120412RN	12,70	12,90	1,2	-	-	●	-	-	-	-	-	-	-	-	-	-	-	-	-	-	-	-	-	-	-	-	-	-	-	-	-	-	-	-
CNMG120416RN	12,70	12,90	1,6	-	-	●	-	-	-	-	-	-	-	-	-	-	-	-	-	-	-	-	-	-	-	-	-	-	-	-	-	-	-	-
CNMG160608RN	15,88	16,12	0,8	-	-	●	-	-	-	-	-	-	-	-	-	-	-	-	-	-	-	-	-	-	-	-	-	-	-	-	-	-	-	-
CNMG160612RN	15,88	16,12	1,2	-	-	●	-	-	-	-	-	-	-	-	-	-	-	-	-	-	-	-	-	-	-	-	-	-	-	-	-	-	-	-
CNMG160616RN	15,88	16,12	1,6	-	-	●	-	-	-	-	-	-	-	-	-	-	-	-	-	-	-	-	-	-	-	-	-	-	-	-	-	-	-	-
CNMG190608RN	19,05	19,34	0,8	-	-	●	-	-	-	-	-	-	-	-	-	-	-	-	-	-	-	-	-	-	-	-	-	-	-	-	-	-	-	-
CNMG190612RN	19,05	19,34	1,2	-	-	●	-	-	-	-	-	-	-	-	-	-	-	-	-	-	-	-	-	-	-	-	-	-	-	-	-	-	-	-
CNMG190616RN	19,05	19,34	1,6	-	-	●	-	-	-	-	-	-	-	-	-	-	-	-	-	-	-	-	-	-	-	-	-	-	-	-	-	-	-	-
CNMG190624RN	19,05	19,34	2,4	-	-	●	-	-	-	-	-	-	-	-	-	-	-	-	-	-	-	-	-	-	-	-	-	-	-	-	-	-	-	-

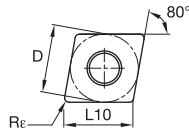
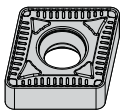

■ CNMU-RN

目录编号	D	L10	Re	KCP05B	KCP05	KCP10B	KCP10	KCP25B	KCP25	KCP30B	KCP30	KCP40B	KCP40	KCK05B	KCK05	KGK15B	KGK15	KCK20B	KCK20	KCM15B	KCM15	KCM25B	KCM25	KCM35B	KCM35	KCPK05	K313	K68	KCU10	KCU25	KC5010	KC5025	KC5410	KT315
CNMU120412RN	12,70	12,90	1,2	-	-	●	-	-	-	-	-	-	-	-	-	-	-	-	-	-	-	-	-	-	-	-	-	-	-	-	-	-	-	-

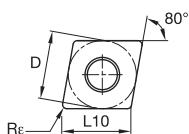
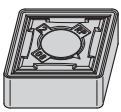

■ CNMG-RP

目录编号	D	L10	Re	KCP05B	KCP05	KCP10B	KCP10	KCP25B	KCP25	KCP30B	KCP30	KCP40B	KCP40	KCK05B	KCK05	KGK15B	KGK15	KCK20B	KCK20	KCM15B	KCM15	KCM25B	KCM25	KCM35B	KCM35	KCPK05	K313	K68	KCU10	KCU25	KC5010	KC5025	KC5410	KT315
CNMG120404RP	12,70	12,90	0,4	-	-	-	●	●	●	-	-	-	-	-	-	-	-	-	-	-	-	-	-	-	-	-	-	-	-	-	-	-	-	-
CNMG120408RP	12,70	12,90	0,8	●	●	●	●	●	●	-	-	-	-	-	-	-	-	-	-	-	-	-	-	-	-	-	-	-	-	-	-	-	-	-
CNMG120412RP	12,70	12,90	1,2	-	●	●	●	●	●	-	-	-	-	-	-	-	-	-	-	-	-	-	-	-	-	-	-	-	-	-	-	-	-	-
CNMG120416RP	12,70	12,90	1,6	-	-	●	●	●	●	-	-	-	-	-	-	-	-	-	-	-	-	-	-	-	-	-	-	-	-	-	-	-	-	-
CNMG160608RP	15,88	16,12	0,8	-	-	●	●	●	●	-	-	-	-	-	-	-	-	-	-	-	-	-	-	-	-	-	-	-	-	-	-	-	-	-
CNMG160612RP	15,88	16,12	1,2	-	-	●	●	●	●	-	-	-	-	-	-	-	-	-	-	-	-	-	-	-	-	-	-	-	-	-	-	-	-	-
CNMG160616RP	15,88	16,12	1,6	-	-	●	●	●	●	-	-	-	-	-	-	-	-	-	-	-	-	-	-	-	-	-	-	-	-	-	-	-	-	-
CNMG190612RP	19,05	19,34	1,2	-	-	●	●	●	●	-	-	-	-	-	-	-	-	-	-	-	-	-	-	-	-	-	-	-	-	-	-	-	-	-
CNMG190616RP	19,05	19,34	1,6	-	-	●	●	●	●	-	-	-	-	-	-	-	-	-	-	-	-	-	-	-	-	-	-	-	-	-	-	-	-	-





● 首选  
○ 备选

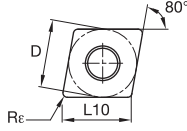
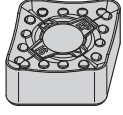

■ CNMM-RP

目录编号	D	L10	Re	KCP05B	KCP05	KCP10B	KCP10	KCP25B	KCP25	KCP30B	KCP30	KCP40B	KCP40	KCK05B	KCK05	KCK15B	KCK15	KCK20B	KCK20	KCM15B	KCM15	KCM25B	KCM25	KCM35B	KCM35	KCPK05	K313	K68	KCU10	KCU25	KC5010	KC5025	KC5410	KT315
CNMM120408RP	12,70	12,90	0,8	-	●	-	-	-	-	-	-	-	-	-	-	-	-	-	-	-	-	-	-	-	-	-	-	-	-	-	-	-	-	-
CNMM120412RP	12,70	12,90	1,2	-	-	●	-	-	-	-	-	-	-	-	-	-	-	-	-	-	-	-	-	-	-	-	-	-	-	-	-	-	-	-
CNMM120416RP	12,70	12,90	1,6	-	-	-	-	●	●	-	-	-	-	-	-	-	-	-	-	-	-	-	-	-	-	-	-	-	-	-	-	-	-	-
CNMM160608RP	15,88	16,12	0,8	-	-	-	-	●	-	-	-	-	-	-	-	-	-	-	-	-	-	-	-	-	-	-	-	-	-	-	-	-	-	-
CNMM160612RP	15,88	16,12	1,2	-	-	-	-	●	●	-	-	-	-	-	-	-	-	-	-	-	-	-	-	-	-	-	-	-	-	-	-	-	-	-
CNMM160616RP	15,88	16,12	1,6	-	-	-	-	●	●	-	-	-	-	-	-	-	-	-	-	-	-	-	-	-	-	-	-	-	-	-	-	-	-	-
CNMM160624RP	15,88	16,12	2,4	-	-	-	-	●	-	-	-	-	-	-	-	-	-	-	-	-	-	-	-	-	-	-	-	-	-	-	-	-	-	-
CNMM190612RP	19,05	19,34	1,2	-	-	-	-	●	●	-	-	-	-	-	-	-	-	-	-	-	-	-	-	-	-	-	-	-	-	-	-	-	-	-
CNMM190616RP	19,05	19,34	1,6	-	-	-	-	●	●	-	-	-	-	-	-	-	-	-	-	-	-	-	-	-	-	-	-	-	-	-	-	-	-	-
CNMM190624RP	19,05	19,34	2,4	-	-	-	-	●	-	-	-	-	-	-	-	-	-	-	-	-	-	-	-	-	-	-	-	-	-	-	-	-	-	-
CNMM250924RP	25,40	25,79	2,4	-	-	-	-	●	-	-	-	-	-	-	-	-	-	-	-	-	-	-	-	-	-	-	-	-	-	-	-	-	-	-

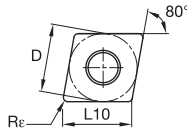
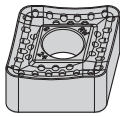

■ CNMM-RW

目录编号	D	L10	Re	KCP05B	KCP05	KCP10B	KCP10	KCP25B	KCP25	KCP30B	KCP30	KCP40B	KCP40	KCK05B	KCK05	KCK15B	KCK15	KCK20B	KCK20	KCM15B	KCM15	KCM25B	KCM25	KCM35B	KCM35	KCPK05	K313	K68	KCU10	KCU25	KC5010	KC5025	KC5410	KT315
CNMM190624RW	19,05	19,34	2,4	-	-	-	●	●	-	-	-	-	-	-	-	-	-	-	-	-	-	-	-	-	-	-	-	-	-	-	-	-	-	-
CNMM250924RW	25,40	25,79	2,4	-	-	-	-	●	-	-	-	-	-	-	-	-	-	-	-	-	-	-	-	-	-	-	-	-	-	-	-	-	-	-

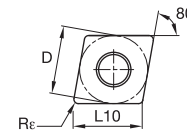
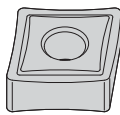

■ CNMP

目录编号	D	L10	Re	KCP05B	KCP05	KCP10B	KCP10	KCP25B	KCP25	KCP30B	KCP30	KCP40B	KCP40	KCK05B	KCK05	KCK15B	KCK15	KCK20B	KCK20	KCM15B	KCM15	KCM25B	KCM25	KCM35B	KCM35	KCPK05	K313	K68	KCU10	KCU25	KC5010	KC5025	KC5410	KT315
CNMP120404	12,70	12,90	0,4	-	-	-	-	-	-	-	-	-	-	-	-	-	-	-	-	-	-	-	-	-	-	-	-	-	-	-	-	-	-	
CNMP120408	12,70	12,90	0,8	-	-	-	-	●	-	-	-	-	-	-	-	-	-	-	-	-	-	-	-	-	-	-	-	-	-	-	-	-	-	-
CNMP120412	12,70	12,90	1,2	-	-	-	-	●	-	-	-	-	-	-	-	-	-	-	-	-	-	-	-	-	-	-	-	-	-	-	-	-	-	-
CNMP160608	15,88	16,12	0,8	-	-	-	-	●	-	-	-	-	-	-	-	-	-	-	-	-	-	-	-	-	-	-	-	-	-	-	-	-	-	-
CNMP190612	19,05	19,34	1,2	-	-	-	-	●	-	-	-	-	-	-	-	-	-	-	-	-	-	-	-	-	-	-	-	-	-	-	-	-	-	-

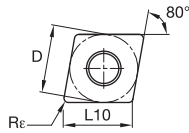
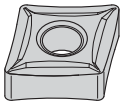

● 首选  
 ○ 备选

**■ CNMP-K**

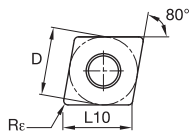
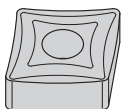
目录编号	D	L10	Re	KCP05B	KCP05	KCP10B	KCP10	KCP25B	KCP25	KCP30B	KCP30	KCP40B	KCP40	KCK05B	KCK05	KCK15B	KCK15	KCK20B	KCK20	KCM15B	KCM15	KCM25B	KCM25	KCM35B	KCM35	KCPK05	K313	K68	KCU10	KCU25	KC5010	KC5025	KC5410	KT315	
CNMP120404K	12,70	12,90	0,4	-	-	●	○	●	○	-	-	-	○	-	●	○	-	-	-	-	○	○	○	○	○	○	○	○	○	○	○	○	○	○	○
CNMP120408K	12,70	12,90	0,8	-	-	●	○	●	○	-	-	-	○	-	●	○	-	-	-	-	○	○	○	○	○	○	○	○	○	○	○	○	○	○	○

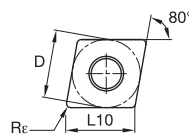
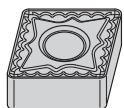

**■ CNMS**

目录编号	D	L10	Re	KCP05B	KCP05	KCP10B	KCP10	KCP25B	KCP25	KCP30B	KCP30	KCP40B	KCP40	KCK05B	KCK05	KCK15B	KCK15	KCK20B	KCK20	KCM15B	KCM15	KCM25B	KCM25	KCM35B	KCM35	KCPK05	K313	K68	KCU10	KCU25	KC5010	KC5025	KC5410	KT315
CNMS120408	12,70	12,90	0,8	-	-	-	-	-	-	-	-	-	-	-	-	-	-	-	-	-	-	-	-	-	-	-	-	-	-	-	-	-	-	-
CNMS160608	15,88	16,12	0,8	-	-	-	-	-	-	-	-	-	-	-	-	-	-	-	-	-	-	-	-	-	-	-	-	-	-	-	-	-	-	-
CNMS190608	19,05	19,34	0,8	-	-	-	-	-	-	-	-	-	-	-	-	-	-	-	-	-	-	-	-	-	-	-	-	-	-	-	-	-	-	-
CNMS190612	19,05	19,34	1,2	-	-	-	-	-	-	-	-	-	-	-	-	-	-	-	-	-	-	-	-	-	-	-	-	-	-	-	-	-	-	-

**■ CNMG-MG**

目录编号	D	L10	Re	KCP05B	KCP05	KCP10B	KCP10	KCP25B	KCP25	KCP30B	KCP30	KCP40B	KCP40	KCK05B	KCK05	KCK15B	KCK15	KCK20B	KCK20	KCM15B	KCM15	KCM25B	KCM25	KCM35B	KCM35	KCPK05	K313	K68	KCU10	KCU25	KC5010	KC5025	KC5410	KT315
CNMG120408MG	12,70	12,90	0,8	-	-	●	○	●	○	-	-	-	-	-	-	-	-	-	-	-	-	-	-	-	-	-	-	-	-	-	-	-	-	-
CNMG120412MG	12,70	12,90	1,2	-	-	●	○	●	○	-	-	-	-	-	-	-	-	-	-	-	-	-	-	-	-	-	-	-	-	-	-	-	-	-
CNMG120416MG	12,70	12,90	1,6	-	-	●	○	●	○	-	-	-	-	-	-	-	-	-	-	-	-	-	-	-	-	-	-	-	-	-	-	-	-	-
CNMG160612MG	15,88	16,12	1,2	-	-	-	-	●	○	-	-	-	-	-	-	-	-	-	-	-	-	-	-	-	-	-	-	-	-	-	-	-	-	-
CNMG160616MG	15,88	16,12	1,6	-	-	●	○	●	○	-	-	-	-	-	-	-	-	-	-	-	-	-	-	-	-	-	-	-	-	-	-	-	-	-
CNMG190612MG	19,05	19,34	1,2	-	-	-	-	●	○	-	-	-	-	-	-	-	-	-	-	-	-	-	-	-	-	-	-	-	-	-	-	-	-	-

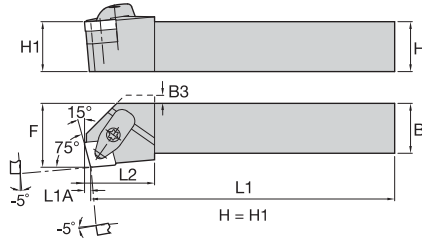
ISO 车削刀具



■ DCKN-KC 75°



订货号	目录编号	H	B	F	L1	LH	L1A	B3	刀片	垫片	垫片螺钉	Torx Plus	夹具配件	Torx Plus	槽销	可选择锁定销
右手																
2273083	DCKNR2020K12KC04	20	20	25,0	125	32,0	3,1	6,0	CN..120408	ICSN433	KMSP415IP	15 IP	CM234R ASSY	15 IP	SSP025016M	KLM4615IP
1875200	DCKNR2525M12KC04	25	25	32,0	150	32,0	3,1	—	CN..120408	ICSN443	KMSP415IP	15 IP	CM234R ASSY	15 IP	SSP025016M	KLM4615IP
2273084	DCKNR3225P12KC04	32	25	32,0	170	32,0	3,1	—	CN..120408	ICSN443	KMSP415IP	15 IP	CM234R ASSY	15 IP	SSP025016M	KLM46L15IP
2273085	DCKNR3232P16KC06	32	32	40,0	170	32,0	3,8	—	CN..160612	ICSN543	KMSP515IP	15 IP	CM209R ASSY	15 IP	SSP025016M	KLM58L15IP
左手																
2273087	DCKNL2020K12KC04	20	20	25,0	125	32,0	3,1	6,0	CN..120408	ICSN433	KMSP415IP	15 IP	CM234R ASSY	15 IP	SSP025016M	KLM4615IP
1875204	DCKNL2525M12KC04	25	25	32,0	150	32,0	3,1	—	CN..120408	ICSN443	KMSP415IP	15 IP	CM234R ASSY	15 IP	SSP025016M	KLM4615IP
2273088	DCKNL3225P12KC04	32	25	32,0	170	32,0	3,1	—	CN..120408	ICSN443	KMSP415IP	15 IP	CM234R ASSY	15 IP	SSP025016M	KLM46L15IP

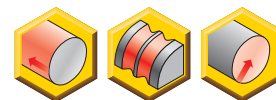
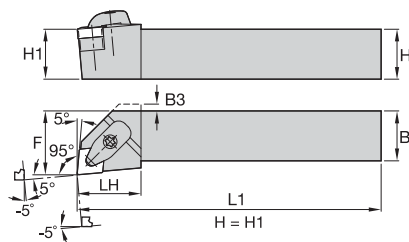
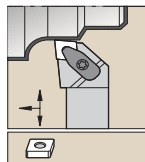

ISO 车削刀具

■ DCLN-KC 95°



订货号	目录编号	H	B	F	L1	LH	B3	刀片	垫片	垫片螺钉	Torx Plus	夹具装配件	Torx Plus	槽销	可选择锁定销
右手															
2417296	DCLNR1616H09KC03	16	16	20,0	100	30,0	6,0	CN..090308	ICSN332	KMSP315IP	9 IP	CM234R ASSY	15 IP	SSP025016M	KLM34L9IP
1875199	DCLNR2020K12KC04	20	20	25,0	125	32,0	4,0	CN..120408	ICSN433	KMSP415IP	15 IP	CM234R ASSY	15 IP	SSP025016M	KLM4615IP
1875193	DCLNR2525M12KC04	25	25	32,0	150	32,0	—	CN..120408	ICSN443	KMSP415IP	15 IP	CM234R ASSY	15 IP	SSP025016M	KLM46L15IP
1875212	DCLNR2525M16KC06	25	25	32,0	150	33,0	—	CN..160612	ICSN543	KMSP515IP	15 IP	CM209R ASSY	15 IP	SSP025016M	KLM58L15IP
1875223	DCLNR3225P12KC04	32	25	32,0	170	32,0	—	CN..120408	ICSN443	KMSP415IP	15 IP	CM234R ASSY	15 IP	SSP025016M	KLM46L15IP
1875232	DCLNR3225P16KC06	32	25	32,0	170	33,0	—	CN..160612	ICSN543	KMSP515IP	15 IP	CM209R ASSY	15 IP	SSP025016M	KLM58L15IP
1875224	DCLNR3232P16KC06	32	32	40,0	170	33,0	—	CN..160612	ICSN543	KMSP515IP	15 IP	CM209R ASSY	15 IP	SSP025016M	KLM58L15IP
2273091	DCLNR3232P19KC06	32	32	40,0	170	40,0	—	CN..190612	ICSN643	KMSP625IP	25 IP	CM210R ASSY	25 IP	SSP025016M	KLM68L25IP
2273092	DCLNR4040S19KC06	40	40	50,0	250	40,0	—	CN..190612	ICSN643	KMSP625IP	25 IP	CM210R ASSY	25 IP	SSP025016M	KLM68L25IP
左手															
1875194	DCLNL2020K12KC04	20	20	25,0	125	32,0	4,0	CN..120408	ICSN433	KMSP415IP	15 IP	CM234R ASSY	15 IP	SSP025016M	KLM4615IP
1875196	DCLNL2525M12KC04	25	25	32,0	150	32,0	—	CN..120408	ICSN443	KMSP415IP	15 IP	CM234R ASSY	15 IP	SSP025016M	KLM46L15IP
1875205	DCLNL2525M16KC06	25	25	32,0	150	33,0	—	CN..160612	ICSN543	KMSP515IP	15 IP	CM209R ASSY	15 IP	SSP025016M	KLM58L15IP
1875231	DCLNL3225P12KC04	32	25	32,0	170	32,0	—	CN..120408	ICSN443	KMSP415IP	15 IP	CM234R ASSY	15 IP	SSP025016M	KLM46L15IP
1875230	DCLNL3225P16KC06	32	25	32,0	170	33,0	—	CN..160612	ICSN543	KMSP515IP	15 IP	CM209R ASSY	15 IP	SSP025016M	KLM58L15IP
1875225	DCLNL3232P16KC06	32	32	40,0	170	33,0	—	CN..160612	ICSN543	KMSP515IP	15 IP	CM209R ASSY	15 IP	SSP025016M	KLM58L15IP
2273093	DCLNL3232P19KC06	32	32	40,0	170	40,0	—	CN..190612	ICSN643	KMSP625IP	25 IP	CM210R ASSY	25 IP	SSP025016M	KLM68L25IP
2273094	DCLNL4040S19KC06	40	40	50,0	250	40,0	—	CN..190612	ICSN643	KMSP625IP	25 IP	CM210R ASSY	25 IP	SSP025016M	KLM68L25IP

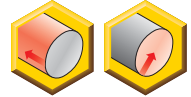
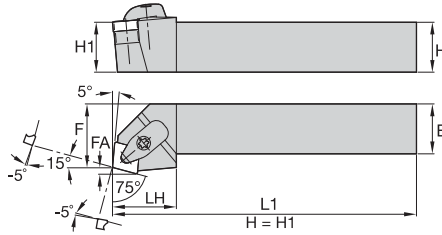

■ DCRN-KC 75°



订货号	目录编号	H	B	F	L1	LH	FA	刀片	垫片	垫片螺钉	Torx Plus	夹具装配件	Torx Plus	槽销	可选择锁定销
右手															
1875226	DCRNR2020K12KC04	20	20	25,0	125	32,0	3,3	CN..120408	ICSN433 KMSP415IP	15 IP	CM234R ASSY	15 IP	SSP025016M	KLM4615IP	
1875201	DCRNR2525M12KC04	25	25	32,0	150	32,0	3,3	CN..120408	ICSN443 KMSP415IP	15 IP	CM234R ASSY	15 IP	SSP025016M	KLM46L15IP	
2273095	DCRNR3225P12KC04	32	25	32,0	170	32,0	3,3	CN..120408	ICSN443 KMSP415IP	15 IP	CM234R ASSY	15 IP	SSP025016M	KLM46L15IP	
2273097	DCRNR3232P19KC06	32	32	40,0	170	38,0	4,9	CN..190612	ICSN643 KMSP625IP	25 IP	CM210R ASSY	25 IP	SSP025016M	KLM68L25IP	
左手															
1875206	DCRNL2525M12KC04	25	25	32,0	150	32,0	3,3	CN..120408	ICSN443 KMSP415IP	15 IP	CM234R ASSY	15 IP	SSP025016M	KLM46L15IP	
2273099	DCRNL3232P16KC06	32	32	40,0	170	38,0	4,1	CN..160612	ICSN543 KMSP515IP	15 IP	CM209R ASSY	15 IP	SSP025016M	KLM58L15IP	

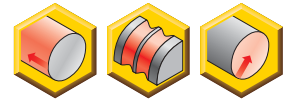
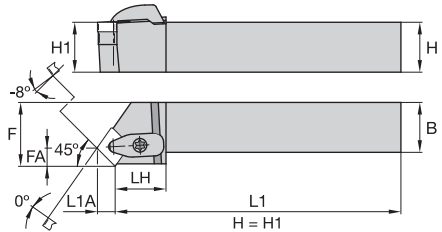
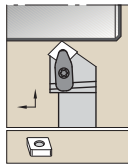

■ DCSN-KC 45°



订货号	目录编号	H	B	F	L1	LH	FA	L1A	刀片	垫片	垫片螺钉	Torx Plus	夹具装配件	Torx Plus	槽销	可选择锁定销
右手																
2273101	DCSNR2020K12KC04	20	20	25,0	125	35,0	8,2	8,5	CN..120408	ICSN433 KMSP415IP	15 IP	CM234R ASSY	15 IP	SSP025016M	KLM4615IP	
2273102	DCSNR2525M12KC04	25	25	32,0	150	35,0	8,2	8,5	CN..120408	ICSN443 KMSP415IP	15 IP	CM234R ASSY	15 IP	SSP025016M	KLM46L15IP	
左手																
2273104	DCSNL2525M12KC04	25	25	32,0	150	35,0	8,2	8,5	CN..120408	ICSN443 KMSP415IP	15 IP	CM234R ASSY	15 IP	SSP025016M	KLM46L15IP	

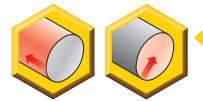
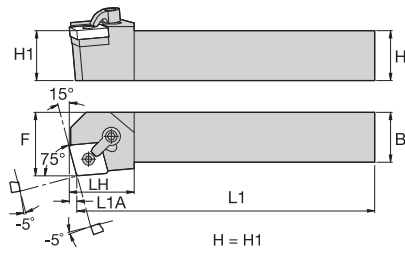
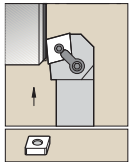

ISO 车削刀具

**■ MCKN 75°**

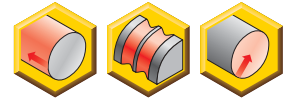
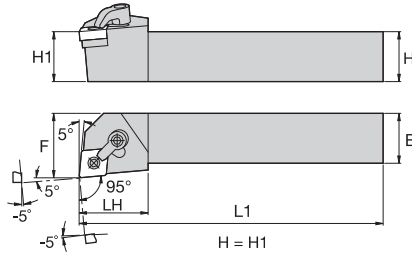
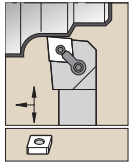

订货号	目录编号	H	B	F	L1	LH	L1A	刀片	垫片	锁销	六角	夹具	夹紧螺钉	六角	
<b>右手</b>															
1102236	MCKNR2525M12	25	25	32,0	150	32,0	3,1	CN..120408	ICSN432	KLM46	2.5 mm	CKM21	STCM20	3 mm	
1102237	MCKNR3225P12	32	25	32,0	170	32,0	3,1	CN..120408	ICSN432	KLM46	2.5 mm	CKM21	STCM20	3 mm	
1102240	MCKNR3225P16	32	25	32,0	170	33,0	3,6	CN..160612	ICSN533	KLM58	3 mm	CKM21	STCM20	3 mm	
<b>左手</b>															
1102729	MCKNL2525M12	25	25	32,0	150	32,0	3,1	CN..120408	ICSN432	KLM46	2.5 mm	CKM21	STCM20	3 mm	
1099253	MCKNL3225P16	32	25	32,0	170	33,0	3,6	CN..160612	ICSN533	KLM58	3 mm	CKM21	STCM20	3 mm	
1102728	MCKNL3232P19	32	32	40,0	170	38,0	4,4	CN..190612	ICSN633	KLM68	4 mm	CKM12	STCM4	4 mm	



■ MCLN 95°

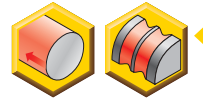
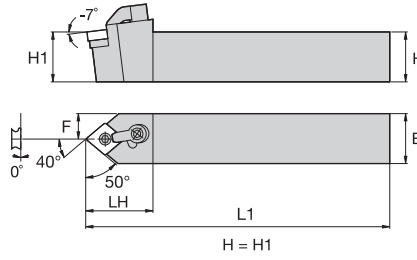
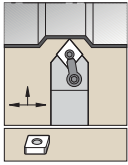

订货号	目录编号	H	B	F	L1	LH	刀片	垫片	锁销	六角	夹具	夹紧螺钉	六角
右手													
1100939	MCLNR1616H09	16	16	20,0	100	25,0	CN..090308	—	KLM33	2 mm	CKM6	STCM5	2.5 mm
1101710	MCLNR1616H12	16	16	20,0	100	32,0	CN..120408	ICSN432	KLM46	2.5 mm	CKM21	STCM20	3 mm
1099132	MCLNR2020K09	20	20	25,0	125	25,0	CN..090308	ICSN332	KLM34L	2 mm	CKM6	STCM5	2.5 mm
1099133	MCLNR2020K12	20	20	25,0	125	32,0	CN..120408	ICSN432	KLM46	2.5 mm	CKM21	STCM20	3 mm
1100943	MCLNR2525M09	25	25	32,0	150	25,0	CN..090308	ICSN332	KLM34L	2 mm	CKM6	STCM5	2.5 mm
1101711	MCLNR2525M12	25	25	32,0	150	32,0	CN..120408	ICSN432	KLM46	2.5 mm	CKM21	STCM20	3 mm
1101641	MCLNR2525M16	25	25	32,0	150	33,0	CNMA160612	ICSN533	KLM58	3 mm	CKM21	STCM20	3 mm
1101704	MCLNR2525M19	25	25	32,0	150	38,0	CN..190612	ICSN633	KLM68	4 mm	CKM12	STCM4	4 mm
1101712	MCLNR3225P12	32	25	32,0	170	32,0	CN..120408	ICSN432	KLM46	2.5 mm	CKM21	STCM20	3 mm
1101642	MCLNR3225P16	32	25	32,0	170	33,0	CN..160612	ICSN533	KLM58	3 mm	CKM21	STCM20	3 mm
1101705	MCLNR3225P19	32	25	32,0	170	38,0	CN..190612	ICSN633	KLM68	4 mm	CKM12	STCM4	4 mm
3595785	MCLNR3232P12	32	32	40,5	171	32,0	CN..120408	ICSN432	KLM46	2.5 mm	CKM21	STCM20	3 mm
3595787	MCLNR3232P16	32	32	40,5	171	33,0	CN..160612	ICSN533	KLM58	3 mm	CKM21	STCM20	3 mm
1101706	MCLNR3232P19	32	32	40,0	170	38,0	CN..190612	ICSN633	KLM68	4 mm	CKM12	STCM4	4 mm
1101707	MCLNR4040R19	40	40	50,0	200	38,0	CN..190612	ICSN633	KLM68	4 mm	CKM12	STCM4	4 mm
左手													
1100938	MCLNL1616H09	16	16	20,0	100	25,0	CN..090308	—	KLM33	2 mm	CKM6	STCM5	2.5 mm
1102539	MCLNL1616H12	16	16	20,0	100	32,0	CN..120408	ICSN432	KLM46	2.5 mm	CKM21	STCM20	3 mm
1102540	MCLNL2020K12	20	20	25,0	125	32,0	CN..120408	ICSN432	KLM46	2.5 mm	CKM21	STCM20	3 mm
1102541	MCLNL2525M12	25	25	32,0	150	32,0	CN..120408	ICSN432	KLM46	2.5 mm	CKM21	STCM20	3 mm
1102440	MCLNL2525M16	25	25	32,0	150	33,0	CNMA160612	ICSN533	KLM58	3 mm	CKM21	STCM20	3 mm
1102534	MCLNL2525M19	25	25	32,0	150	38,0	CN..190612	ICSN633	KLM68	4 mm	CKM12	STCM4	4 mm
1102542	MCLNL3225P12	32	25	32,0	170	32,0	CN..120408	ICSN432	KLM46	2.5 mm	CKM21	STCM20	3 mm
1102442	MCLNL3225P16	32	25	32,0	170	33,0	CN..160612	ICSN533	KLM58	3 mm	CKM21	STCM20	3 mm
1102535	MCLNL3225P19	32	25	32,0	170	38,0	CN..190612	ICSN633	KLM68	4 mm	CKM12	STCM4	4 mm
3595786	MCLNL3232P12	32	32	40,5	171	32,0	CN..120408	ICSN432	KLM46	2.5 mm	CKM21	STCM20	3 mm
3595788	MCLNL3232P16	32	32	40,5	171	33,0	CN..160612	ICSN533	KLM58	3 mm	CKM21	STCM20	3 mm
1102536	MCLNL3232P19	32	32	40,0	170	38,0	CN..190612	ICSN633	KLM68	4 mm	CKM12	STCM4	4 mm
1102537	MCLNL4040R19	40	40	50,0	200	38,0	CN..190612	ICSN633	KLM68	4 mm	CKM12	STCM4	4 mm

**MCMN 50°**

订货号	目录编号	H	B	F	L1	LH	刀片	垫片	锁销	六角	夹具	夹紧螺钉	六角
1101708	MCMNN2020K12	61	20	10,0	125	32,0	CN..120408	ICSN432	KLM46	2.5 mm	CKM21	STCM20	3 mm
1101709	MCMNN2525M12	86	25	12,9	150	32,0	CN..120408	ICSN432	KLM46	2.5 mm	CKM21	STCM20	3 mm
1102538	MCMNN3225P16	94	32	12,9	170	38,0	CN..160612	ICSN533	KLM58	3 mm	CKM21	STCM20	3 mm
1102239	MCMNN4040R19	117	40	20,0	200	42,0	CN..190612	ICSN633	KLM68	4 mm	CKM12	STCM4	4 mm

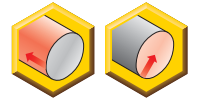
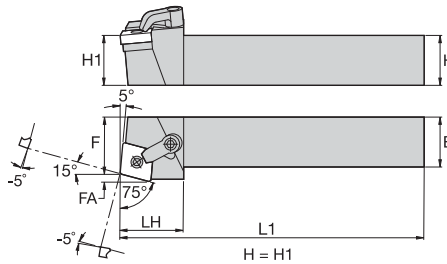
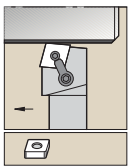
**MCRN 75°**

订货号	目录编号	H	B	F	L1	LH	FA	刀片	垫片	锁销	六角	夹具	夹紧螺钉	六角	
<b>右手</b>															
1101638	MCRNR2020K12	20	20	25,0	125	32,0	3,3	CN..120408	ICSN432	KLM46	2.5 mm	CKM21	STCM20	3 mm	
1101639	MCRNR2525M12	25	25	32,0	150	32,0	3,3	CN..120408	ICSN432	KLM46	2.5 mm	CKM21	STCM20	3 mm	
1101640	MCRNR3225P12	32	25	32,0	170	32,0	3,3	CN..120408	ICSN432	KLM46	2.5 mm	CKM21	STCM20	3 mm	
1102732	MCRNR3232P16	32	32	32,0	170	33,0	4,2	CN..160612	ICSN533	KLM58	3 mm	CKM21	STCM20	3 mm	
1101643	MCRNR3232P19	32	32	40,0	170	38,0	4,6	CN..190612	ICSN633	KLM68	4 mm	CKM12	STCM4	4 mm	
<b>左手</b>															
1102437	MCRNL2525M12	25	25	32,0	150	32,0	3,3	CN..120408	ICSN432	KLM46	2.5 mm	CKM21	STCM20	3 mm	
1102439	MCRNL3225P12	32	25	32,0	170	32,0	3,3	CN..120408	ICSN432	KLM46	2.5 mm	CKM21	STCM20	3 mm	
1102241	MCRNL3232P16	32	32	32,0	170	33,0	4,2	CN..160612	ICSN533	KLM58	3 mm	CKM21	STCM20	3 mm	
1102443	MCRNL3232P19	32	32	40,0	170	38,0	4,6	CN..190612	ICSN633	KLM68	4 mm	CKM12	STCM4	4 mm	

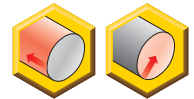
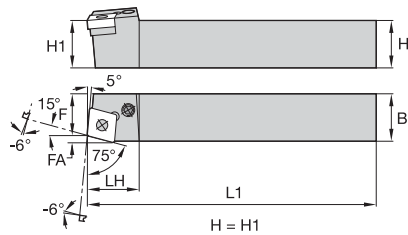
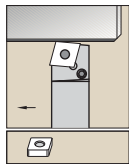

■ PCLN 75°

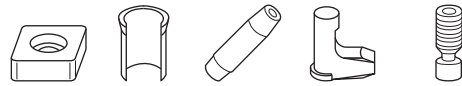

订货号	目录编号	H	B	F	L1	LH	FA	刀片	垫片	垫片销	冲头	杠杆	杠杆螺钉	Torx Plus	
右手															
1244779	PCBNR2525M12	25	25	22,0	150	26,0	3,1	CN..120408	512.112	513.023	515.018	511.023	514.123	15 IP	
1244635	PCBNR2525M16	25	25	22,0	150	28,0	4,2	CN..160612	512.117	513.025	515.022	511.025	514.125	15 IP	
1244636	PCBNR3225P12	32	25	22,0	170	28,0	3,1	CN..120408	512.112	513.023	515.018	511.023	514.123	15 IP	
1244637	PCBNR3225P16	32	25	22,0	170	28,0	4,2	CN..160612	512.117	513.025	515.022	511.025	514.125	15 IP	
1244638	PCBNR3232P16	32	32	27,0	170	38,0	4,2	CN..160612	512.117	513.025	515.022	511.025	514.125	15 IP	
1244795	PCBNR3232P19	32	32	27,0	170	38,0	4,6	CN..190612	512.123	513.033	515.022	511.033	514.133	25 IP	
1192373	PCBNR4040S19	40	40	35,0	250	38,0	4,6	CN..190612	512.123	513.033	515.022	511.033	514.133	25 IP	
左手															
1244630	PCBNL2020K12	20	20	17,0	125	26,0	3,1	CN..120408	512.112	513.023	515.018	511.023	514.123	15 IP	
1244859	PCBNL2525M12	25	25	22,0	150	26,0	3,1	CN..120408	512.112	513.023	515.018	511.023	514.123	15 IP	
1244631	PCBNL2525M16	25	25	22,0	150	28,0	4,2	CN..160612	512.117	513.025	515.022	511.025	514.125	15 IP	
1244794	PCBNL3232P16	32	32	27,0	170	38,0	4,2	CN..160612	512.117	513.025	515.022	511.025	514.125	15 IP	
1244633	PCBNL3232P19	32	32	27,0	170	38,0	4,6	CN..190612	512.123	513.033	515.022	511.033	514.133	25 IP	
1192372	PCBNL4040S19	40	40	35,0	250	38,0	4,6	CN..190612	512.123	513.033	515.022	511.033	514.133	25 IP	

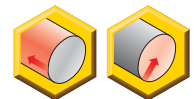
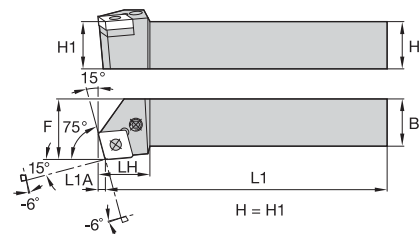
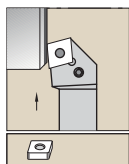

■ PCKN 75°



订货号	目录编号	H	B	F	L1	LH	L1A	刀片	垫片	垫片销	冲头	杠杆	杠杆螺钉	Torx Plus	
右手															
1244649	PCKNR2020K12	20	20	25,0	125	23,0	3,1	CN..120408	512.112	513.023	515.018	511.023	514.123	15 IP	
1244797	PCKNR2525M12	25	25	32,0	150	23,0	3,1	CN..120408	512.112	513.023	515.018	511.023	514.123	15 IP	
1244775	PCKNR2525M16	25	25	32,0	150	30,0	3,8	CN..160612	512.117	513.025	515.022	511.025	514.125	15 IP	
1244650	PCKNR3225P12	32	25	32,0	170	26,0	3,1	CN..120408	512.112	513.023	515.018	511.023	514.123	15 IP	
1244776	PCKNR3225P16	32	25	32,0	170	30,0	3,8	CN..160612	512.117	513.025	515.022	511.025	514.125	15 IP	
1244798	PCKNR3232P19	32	32	40,0	170	37,5	4,6	CN..190612	512.123	513.033	515.022	511.033	514.133	25 IP	
左手															
1244646	PCKNL2020K12	20	20	25,0	125	23,0	3,1	CN..120408	512.112	513.023	515.018	511.023	514.123	15 IP	
1244780	PCKNL2525M12	25	25	32,0	150	23,0	3,1	CN..120408	512.112	513.023	515.018	511.023	514.123	15 IP	
1244647	PCKNL3225P12	32	25	32,0	170	26,0	3,1	CN..120408	512.112	513.023	515.018	511.023	514.123	15 IP	
1244777	PCKNL3225P16	32	25	32,0	170	30,0	3,8	CN..160612	512.117	513.025	515.022	511.025	514.125	15 IP	
1244648	PCKNL3232P19	32	32	40,0	170	37,5	4,6	CN..190612	512.123	513.033	515.022	511.033	514.133	25 IP	

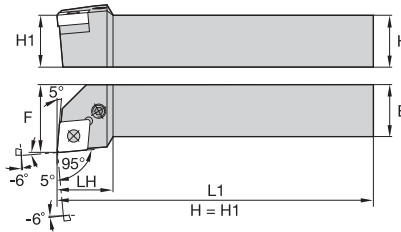
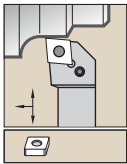
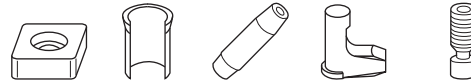

**■ PCLN 95°**

ISO 车削刀具

订货号	目录编号	H	B	F	L1	LH	刀片	垫片	垫片销	冲头	杠杆	杠杆螺钉	Torx Plus
<b>右手</b>													
1244809	PCLNR1616H12	16	16	20,0	100	26,0	CN..120408	512.112	513.023	515.018	511.023	514.123	15 IP
1244810	PCLNR2020K12	20	20	25,0	125	26,0	CN..120408	512.112	513.023	515.018	511.023	514.123	15 IP
1108097	PCLNR2525M12	25	25	32,0	150	26,0	CN..120408	512.112	513.023	515.018	511.023	514.123	15 IP
1192378	PCLNR2525M16	25	25	32,0	150	28,0	CN..160612	512.117	513.025	515.022	511.025	514.125	15 IP
1244652	PCLNR2525M19	25	25	32,0	150	36,0	CN..190612	512.123	513.033	515.022	511.033	514.133	25 IP
1244811	PCLNR3225P12	32	25	32,0	170	26,0	CN..120408	512.112	513.023	515.018	511.023	514.123	15 IP
1244812	PCLNR3225P16	32	25	32,0	170	38,0	CN..160612	512.117	513.025	515.022	511.025	514.125	15 IP
1244653	PCLNR3225P19	32	25	32,0	170	38,0	CN..190612	512.123	513.033	515.022	511.033	514.133	25 IP
1236864	PCLNR3232P16	32	32	40,0	170	36,0	CN..160612	512.117	513.025	515.022	511.025	514.125	15 IP
1244813	PCLNR3232P19	32	32	40,0	170	36,0	CN..190612	512.123	513.033	515.022	511.033	514.133	25 IP
1192379	PCLNR4040S19	40	40	50,0	250	36,0	CN..190612	512.123	513.033	515.022	511.033	514.133	25 IP
<b>左手</b>													
1244799	PCLNL1616H12	16	16	20,0	100	26,0	CN..120408	512.112	513.023	515.018	511.023	514.123	15 IP
1156962	PCLNL2020K12	20	20	25,0	125	26,0	CN..120408	512.112	513.023	515.018	511.023	514.123	15 IP
1192375	PCLNL2525M12	25	25	32,0	150	26,0	CN..120408	512.112	513.023	515.018	511.023	514.123	15 IP
1192376	PCLNL2525M16	25	25	32,0	150	28,0	CN..160612	512.117	513.025	515.022	511.025	514.125	15 IP
1244800	PCLNL2525M19	25	25	32,0	150	36,0	CN..190612	512.123	513.033	515.022	511.033	514.133	25 IP
1244858	PCLNL3225P12	32	25	32,0	170	26,0	CN..120408	512.112	513.023	515.018	511.023	514.123	15 IP
1244802	PCLNL3225P16	32	25	32,0	170	38,0	CN..160612	512.117	513.025	515.022	511.025	514.125	15 IP
1244803	PCLNL3225P19	32	25	32,0	170	38,0	CN..190612	512.123	513.033	515.022	511.033	514.133	25 IP
1244804	PCLNL3232P16	32	32	40,0	170	36,0	CN..160612	512.117	513.025	515.022	511.025	514.125	15 IP
1244805	PCLNL3232P19	32	32	40,0	170	36,0	CN..190612	512.123	513.033	515.022	511.033	514.133	25 IP
1192377	PCLNL4040S19	40	40	50,0	250	36,0	CN..190612	512.123	513.033	515.022	511.033	514.133	25 IP

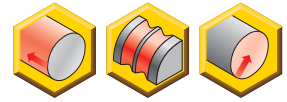
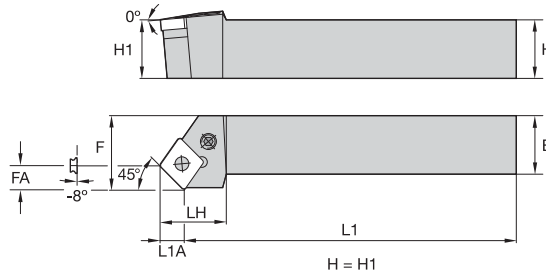
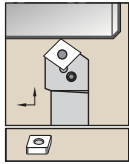

■ PCSN 45°



订货号	目录编号	H	B	F	L1	LH	FA	L1A	刀片	垫片	垫片销	冲头	杠杆	杠杆螺钉	Torx Plus
右手															
1244656	PCSNR2020K12	20	20	25,0	125	26,0	8,3	8,5	CN..120408	512.112	513.023	515.018	511.023	514.123	15 IP
1244818	PCSNR2525M12	25	25	32,0	150	28,0	8,3	8,5	CN..120408	512.112	513.023	515.018	511.023	514.123	15 IP
1244657	PCSNR3225P12	32	25	32,0	170	29,0	8,3	8,5	CN..120408	512.112	513.023	515.018	511.023	514.123	15 IP
1244819	PCSNR3232P19	32	32	40,0	170	37,5	12,5	12,7	CN..190612	512.123	513.033	515.022	511.033	514.133	25 IP
左手															
1244654	PCSNL2020K12	20	20	25,0	125	26,0	8,3	8,5	CN..120408	512.112	513.023	515.018	511.023	514.123	15 IP
1244655	PCSNL2525M12	25	25	32,0	150	28,0	8,3	8,5	CN..120408	512.112	513.023	515.018	511.023	514.123	15 IP
1284109	PCSNL3225P12	32	25	32,0	170	29,0	8,3	8,5	CN..120408	512.112	513.023	515.018	511.023	514.123	15 IP
1244817	PCSNL3232P19	32	32	40,0	170	37,5	12,5	12,7	CN..190612	512.123	513.033	515.022	511.033	514.133	25 IP

Kenclamp™ 镗杆

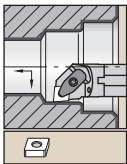

带有内冷的钢刀柄。

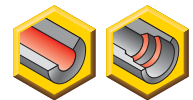
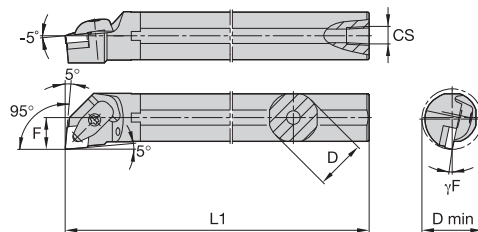

■ A-DCLN-KC 95°



订货号	目录编号	D	D min	F	L1	CS	γF°	刀片	垫片	垫片螺钉	Torx Plus	夹具装配件	槽销	Torx Plus
右手														
2441867	A25RDCLNR12KC04	25	32,0	17,0	200	1/4-18 NPT	-12,0	CN.120408	—	—	15 IP	CM234R ASSY	SSP025016M	15 IP
2441931	A32SDCLNR12KC04	32	40,0	22,0	250	1/4-18 NPT	-12,0	CN.120408	ICSN433	KMSP415IP	15 IP	CM234R ASSY	SSP025016M	15 IP
2441933	A40TDCLNR12KC04	40	50,0	27,0	300	1/4-18 NPT	-9,0	CN..120408	ICSN433	KMSP415IP	15 IP	CM234R ASSY	SSP025016M	15 IP
左手														
2441930	A25RDCLNL12KC04	25	32,0	17,0	200	1/4-18 NPT	-12,0	CN.120408	—	—	15 IP	CM234R ASSY	SSP025016M	15 IP
2441932	A32SDCLNL12KC04	32	40,0	22,0	250	1/4-18 NPT	-12,0	CN.120408	ICSN433	KMSP415IP	15 IP	CM234R ASSY	SSP025016M	15 IP
2441934	A40TDCLNL12KC04	40	50,0	27,0	300	1/4-18 NPT	-9,0	CN.120408	ICSN433	KMSP415IP	15 IP	CM234R ASSY	SSP025016M	15 IP
2441938	A40TDCLNL16KC06	40	50,0	27,0	300	1/4-18 NPT	-12,0	CN..160612	ICSN533	KMSP515IP	15 IP	CM209R ASSY	SSP025018M	15 IP

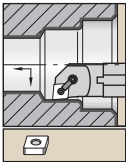

带有内冷的钢刀柄。

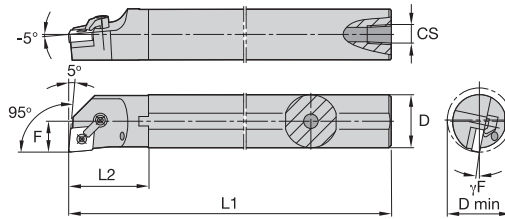

ISO 车削刀具

**■ A-MCLN 95°**

订货号	目录编号	D	D min	F	L1	L2	CS	γF°	刀片	垫片	锁销	六角	夹具	夹紧螺钉	六角
<b>右手</b>															
1098767	A25RMCLNR09	25	32,0	17,0	200	40,0	1/4-18 NPT	-12.0	CN..090308	—	KLM33	2 mm	CKM6	STCM5	2.5 mm
1098088	A25RMCLNR12	25	32,0	17,0	200	33,0	1/4-18 NPT	-12.0	CN..120408	—	KLM43	2 mm	CKM21	STCM11	3 mm
1098090	A32SMCLNR12	32	40,0	22,0	250	—	1/4-18 NPT	-12.0	CN..120408	ICSN432	KLM46	2.5 mm	CKM21	STCM20	3 mm
1098092	A40TMCLNR12	40	50,0	27,0	300	—	1/4-18 NPT	-12.0	CN..120408	ICSN432	KLM46	2.5 mm	CKM21	STCM20	3 mm
1098096	A40TMCLNR16	40	50,0	27,0	300	—	1/4-18 NPT	-11.0	CN..160612	ICSN533	KLM58	3 mm	CKM21	STCM20	3 mm
1098094	A50UMCLNR12	50	63,0	35,0	350	—	1/4-18 NPT	-12.0	CN..120408	ICSN432	KLM46	2.5 mm	CKM21	STCM20	3 mm
1098098	A50UMCLNR16	50	63,0	35,0	350	—	1/4-18 NPT	-12.0	CN..160608	ICSN533	KLM58	3 mm	CKM21	STCM20	3 mm
1098100	A50UMCLNR19	50	63,0	35,0	350	—	1/4-18 NPT	-12.0	CN..190608	ICSN633	KLM68	4 mm	CKM12	STCM4	4 mm
<b>左手</b>															
1098089	A25RMCLNL12	25	32,0	17,0	200	33,0	1/4-18 NPT	-12.0	CN..120408	—	KLM43	2 mm	CKM21	STCM11	3 mm
1098091	A32SMCLNL12	32	40,0	22,0	250	—	1/4-18 NPT	-12.0	CN..120408	ICSN432	KLM46	2.5 mm	CKM21	STCM20	3 mm
1098093	A40TMCLNL12	40	50,0	27,0	300	—	1/4-18 NPT	-12.0	CN..120408	ICSN432	KLM46	2.5 mm	CKM21	STCM20	3 mm
1098097	A40TMCLNL16	40	50,0	27,0	300	—	1/4-18 NPT	-11.0	CN..160608	ICSN533	KLM58	3 mm	CKM21	STCM20	3 mm
1098095	A50UMCLNL12	50	63,0	35,0	350	—	1/4-18 NPT	-7.0	CN..120408	ICSN432	KLM46	2.5 mm	CKM21	STCM20	3 mm
1098099	A50UMCLNL16	50	63,0	35,0	350	—	1/4-18 NPT	-12.0	CN..160608	ICSN533	KLM58	3 mm	CKM21	STCM20	3 mm
1098101	A50UMCLNL19	50	63,0	35,0	350	—	1/4-18 NPT	-12.0	CN..190608	ICSN633	KLM68	4 mm	CKM12	STCM4	4 mm

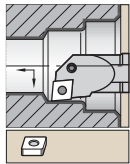

带有冷功能的钢质刀柄。

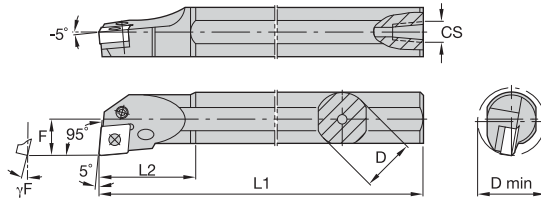

■ A-PCLN 95°



订货号	目录编号	D	D min	F	L1	L2	CS	γF°	刀片	垫片	垫片销	销	杠杆	杠杆螺钉	Torx Plus
右手															
2447150	A25TPCLNR12	25	32,0	17,0	300	40	1/4-18 NPT	-12,0	CN..120408	—	—	—	511.022	514.122	10 IP
2447152	A32UPCLNR12	32	40,0	22,0	350	50	1/4-18 NPT	-10,0	CN..120408	512.112	513.023	515.018	511.023	514.123	15 IP
2447476	A32UPCLNR16	32	50,0	22,0	350	50	1/4-18 NPT	-10,0	CN..160612	512.117	513.025	515.022	511.025	514.125	15 IP
2447533	A40VPCLNR12	40	50,0	27,0	400	55	1/4-18 NPT	-10,0	CN..120408	512.112	513.023	515.018	511.023	514.123	15 IP
2447478	A40VPCLNR16	40	50,0	27,0	400	55	1/4-18 NPT	-11,0	CN..160612	512.117	513.025	515.022	511.025	514.125	15 IP
左手															
2447151	A25TPCLNL12	25	32,0	17,0	300	40	1/4-18 NPT	-12,0	CN..120408	—	—	—	511.022	514.122	10 IP
2447473	A32UPCLNL12	32	40,0	22,0	350	50	1/4-18 NPT	-10,0	CN..120408	512.112	513.023	515.018	511.023	514.123	15 IP
2447534	A40VPCLNL12	40	50,0	27,0	400	55	1/4-18 NPT	-10,0	CN..120408	512.112	513.023	515.018	511.023	514.123	15 IP
2447479	A40VPCLNL16	40	50,0	27,0	400	55	1/4-18 NPT	-11,0	CN..160612	512.117	513.025	515.022	511.025	514.125	15 IP

Kenloc™ 镗头

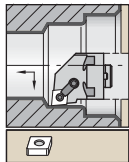

带有内冷。

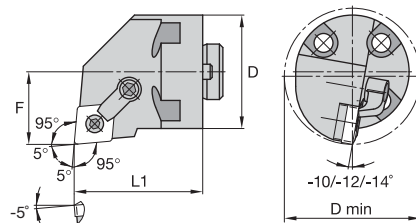

■ H-MCLN 95°



订货号	目录编号	D	D min	F	L1	刀片	垫片	锁销	六角	夹具	夹紧螺钉	六角
右手												
3612156	H32MCLNR12	32	40,0	22,0	41	CN..120408	ICSN432	KLM46	2.5 mm	CKM21	STCM20	3 mm
3612178	H50MCLNR12	50	63,0	35,0	41	CN..120408	ICSN432	KLM46	2.5 mm	CKM20	STCM20	3 mm
1099102	H50MCLNR19	50	63,0	35,0	41	CN..190612	ICSN633	KLM68	4 mm	CKM12	STCM4	4 mm

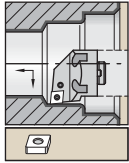

带有内冷。

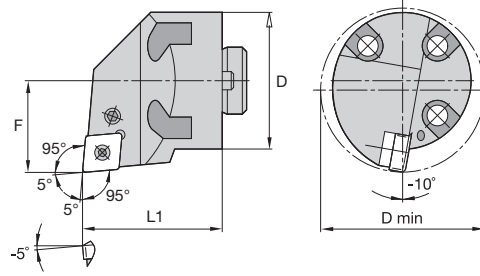
**■ H-PCLN 95°**

订货号	目录编号	D	D min	F	L1	刀片	垫片	垫片销	杠杆	冲头	杠杆螺钉	六角
右手												
1861493	H32PCLNR12	32	40,0	22,0	41	CN..120408	512.112	513.023	514.123	515.018	514.123	15 IP
1861500	H40PCLNR12	40	50,0	27,0	41	CN..120408	512.112	513.023	514.123	515.018	514.123	15 IP
1861517	H50PCLNR12	50	63,0	35,0	41	CN..120408	512.112	513.023	514.123	515.018	514.123	15 IP
左手												
1861501	H40PCLNL12	40	50,0	27,0	41	CN..120408	512.112	513.023	514.123	515.018	514.123	15 IP
1861518	H50PCLNL12	50	63,0	35,0	41	CN..120408	512.112	513.023	514.123	515.018	514.123	15 IP

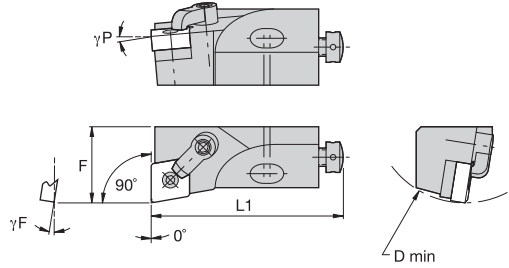
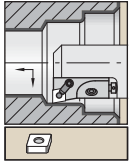

■ MCFN 90°

订货号	目录编号	D min	F	L1	$\gamma_F^\circ$	$\gamma_P^\circ$	刀片
<b>右手</b>							
3331146	MCFNR10CA09	40	14,0	50	-9.0	-9.0	CN..090308/CN..322
3346236	MCFNR12CA12	50	20,0	55	-9.0	-5.0	CN..120408/CN..432
2074433	MCFNR16CA12	60	25,0	63	-9.0	-5.0	CN..120408/CN..432
3330195	MCFNR20CA12	70	25,0	70	-9.0	-5.0	CN..120408/CN..432
<b>左手</b>							
3331145	MCFNL10CA09	40	14,0	50	-9.0	-9.0	CN..090308/CN..322
1906272	MCFNL12CA12	50	20,0	55	-9.0	-5.0	CN..120408/CN..432

■ 配件

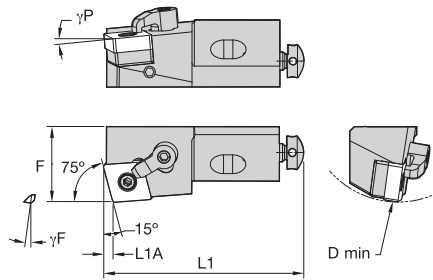

D min	垫片	锁销	六角	夹具	夹紧螺钉	六角	径向调节螺钉	六角	轴向调整螺钉	安装螺钉	安装螺钉	六角	垫片
40	—	KLM33	2 mm	CKM36	STCM38	2 mm	KUAM28	2 mm	KUAM30	191.405	—	4 mm	CSWM 060 050
50	—	KLM43	2 mm	CKM34	STCM38	2 mm	KUAM22	2 mm	KUAM31	—	191.406	4 mm	CSWM 060 050
60	ICSN432	KLM46S	2.5 mm	CKM34	STCM9	2.5 mm	KUAM25	2.5 mm	KUAM32	—	191.407	5 mm	CSWM 080 050
70	ICSN432	KLM46	2.5 mm	CKM34	STCM9	2.5 mm	KUAM25	2.5 mm	KUAM32	—	191.407	5 mm	CSWM 080 050

**■ MCKN 75°**

订货号	目录编号	D min	F	L1	L1A	$\gamma^F$	$\gamma^P$	刀片
右手								
3346238	MCKNR12CA12	50	20,0	55	3	-9.0	-5.0	CN..120408/CN..432
3330222	MCKNR16CA12	60	25,0	63	3	-9.0	-5.0	CN..120408/CN..432
左手								
3346237	MCKNL12CA12	50	20,0	55	3	-9.0	-5.0	CN..120408/CN..432

**■ 配件**

D min	垫片	锁销	六角	夹具	夹紧螺钉	六角	径向调节螺钉	六角	轴向调整螺钉	安装螺钉	六角	垫片
50	—	KLM43	2 mm	CKM34	STCM38	2 mm	KUAM22	2 mm	KUAM31	191.406	4 mm	CSWM 060 050
60	ICSN432	KLM46S	2.5 mm	CKM34	STCM9	2.5 mm	KUAM25	2.5 mm	KUAM32	191.407	5 mm	CSWM 080 050

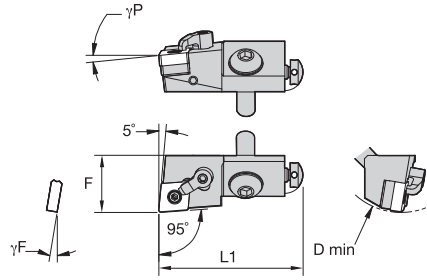
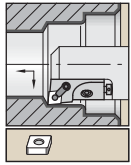

■ MCLN 95°

订货号	目录编号	D min	F	L1	γF°	γP°	刀片
<b>右手</b>							
1100493	MCLNR12CA12	50	20,0	55	-9.0	-5.0	CN..120408/CN..432
1282100	MCLNR16CA12	60	25,0	63	-9.0	-5.0	CN..120408/CN..432
3330197	MCLNR20CA12	70	25,0	70	-9.0	-5.0	CN..120408/CN..432
3332803	MCLNR25CA12	100	32,0	100	-9.0	-5.0	CN..120408/CN..432
3332804	MCLNR25CA16	100	32,0	100	-9.0	-5.0	CN..160612/CN..543
3332805	MCLNR25CA19	100	32,0	100	-9.0	-5.0	CN..190612/CN..643
<b>左手</b>							
2077947	MCLNL12CA12	50	20,0	55	-9.0	-5.0	CN..120408/CN..432
3330273	MCLNL16CA12	60	25,0	63	-9.0	-5.0	CN..120408/CN..432
3330196	MCLNL20CA12	70	25,0	70	-9.0	-5.0	CN..120408/CN..432
3332362	MCLNL25CA19	100	32,0	100	-9.0	-5.0	CN..190612/CN..643

注：根据 D 最小值和已选刀片尺寸选择配件产品。

■ 配件



D min	垫片	锁销	六角	夹具	夹紧螺钉	六角	径向调节螺钉	六角	轴向调整螺钉	安装螺钉	安装螺钉	六角	垫片
50	—	KLM43	2 mm	CKM34	STCM38	2 mm	KUAM22	2 mm	KUAM31	191.406	—	4 mm	CSWM 060 050
60	ICSN432	KLM46S	2.5 mm	CKM34	STCM9	2.5 mm	KUAM25	2.5 mm	KUAM32	191.407	—	5 mm	CSWM 080 050
70	ICSN432	KLM46	2.5 mm	CKM34	STCM9	2.5 mm	KUAM25	2.5 mm	KUAM32	191.407	—	5 mm	CSWM 080 050
100	ICSN633	KLM68	4 mm	CKM35	STCM8	4 mm	KUAM27	4 mm	KUAM32	—	MS364	8 mm	CSWM 100 080
100	ICSN432	KLM46	2.5 mm	CKM37	STCM40	2.5 mm	KUAM25	2.5 mm	KUAM32	—	MS364	8 mm	CSWM 100 080
100	ICSN533	KLM58	3 mm	CKM41	STCM20	3 mm	KUAM26	3 mm	KUAM32	—	MS364	8 mm	CSWM 100 080
100	ICSN633	KLM68	4 mm	CKM35	STCM8	4 mm	KUAM27	4 mm	KUAM32	—	MS364	8 mm	CSWM 100 080



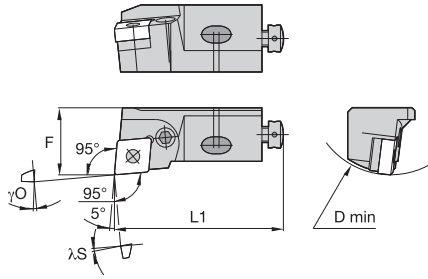
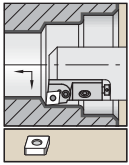

ISO 车削刀具

### ■ PCLN 95°

订货号	目录编号	D min	F	L1	λS°	γ0°	刀片
<b>右手</b>							
1244444	PCLNR12CA-12	50	20,0	55	-6.0	-9.0	CN..120408/CN..432
1244496	PCLNR16CA-12	60	25,0	63	-6.0	-7.0	CN..120408/CN..432
<b>左手</b>							
1244443	PCLNL16CA-12	60	25,0	63	-6.0	-7.0	CN..120408/CN..432

### ■ 配件



D min	垫片	垫片销	杠杆	杠杆螺钉	扳手尺寸调整杆螺钉	径向调节螺钉	六角	轴向调整螺钉	安装螺钉	六角	垫片
50	—	—	511.022	514.122	10 IP	KUAM28	2 mm	KUAM31	191.406	4 mm	CSWM 060 050
60	512.112	513.023	511.023	514.123	15 IP	KUAM23	2.5 mm	KUAM32	191.407	5 mm	CSWM 080 050

● 首选  
○ 备选

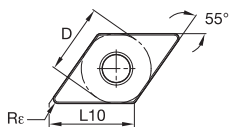
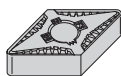

■ DNGG-FS

目录编号	D	L10	Re	KCP05B	KCP05	KCP10B	KCP10	KCP25B	KCP25	KCP30B	KCP30	KCP40B	KCP40	KCK05B	KCK05	KGK15B	KCK15	KCK20B	KCK20	KCM15B	KCM15	KCM25B	KCM25	KCM35B	KCM35	KCPK05	K313	K68	KCU10	KCU25	KC5010	KC5025	KC5410	KT315
DNGG110402FS	9,53	11,63	0,2	●	●	●	●	●	●	●	●	●	●	○	○	○	○	○	○	○	○	○	○	○	○	○	○	○	○	○	○	○	○	○
DNGG110404FS	9,53	11,63	0,4	-	-	-	-	-	-	-	-	-	-	-	-	-	-	-	-	-	-	-	-	-	-	-	-	-	-	-	-	-	-	-
DNGG110408FS	9,53	11,63	0,8	-	-	-	-	-	-	-	-	-	-	-	-	-	-	-	-	-	-	-	-	-	-	-	-	-	-	-	-	-	-	-
DNGG150401FS	12,70	15,50	0,1	-	-	-	-	-	-	-	-	-	-	-	-	-	-	-	-	-	-	-	-	-	-	-	-	-	-	-	-	-	-	-
DNGG150402FS	12,70	15,50	0,2	-	-	-	-	-	-	-	-	-	-	-	-	-	-	-	-	-	-	-	-	-	-	-	-	-	-	-	-	-	-	-
DNGG150404FS	12,70	15,50	0,4	-	-	-	-	-	-	-	-	-	-	-	-	-	-	-	-	-	-	-	-	-	-	-	-	-	-	-	-	-	-	-
DNGG150604FS	12,70	15,50	0,4	-	-	-	-	-	-	-	-	-	-	-	-	-	-	-	-	-	-	-	-	-	-	-	-	-	-	-	-	-	-	-
DNGG150408FS	12,70	15,50	0,8	-	-	-	-	-	-	-	-	-	-	-	-	-	-	-	-	-	-	-	-	-	-	-	-	-	-	-	-	-	-	-
DNGG150608FS	12,70	15,50	0,8	-	-	-	-	-	-	-	-	-	-	-	-	-	-	-	-	-	-	-	-	-	-	-	-	-	-	-	-	-	-	-
DNGG150412FS	12,70	15,50	1,2	-	-	-	-	-	-	-	-	-	-	-	-	-	-	-	-	-	-	-	-	-	-	-	-	-	-	-	-	-	-	-

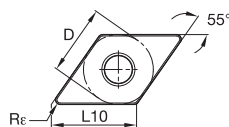
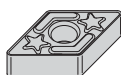

■ DNGG-LF

目录编号	D	L10	Re	KCP05B	KCP05	KCP10B	KCP10	KCP25B	KCP25	KCP30B	KCP30	KCP40B	KCP40	KCK05B	KCK05	KGK15B	KCK15	KCK20B	KCK20	KCM15B	KCM15	KCM25B	KCM25	KCM35B	KCM35	KCPK05	K313	K68	KCU10	KCU25	KC5010	KC5025	KC5410	KT315
DNGG150402LF	12,70	15,50	0,2	-	-	-	-	-	-	-	-	-	-	-	-	-	-	-	-	-	-	-	-	-	-	-	-	-	-	-	-	-	-	-
DNGG150404LF	12,70	15,50	0,4	-	-	-	-	-	-	-	-	-	-	-	-	-	-	-	-	-	-	-	-	-	-	-	-	-	-	-	-	-	-	-
DNGG150408LF	12,70	15,50	0,8	-	-	-	-	-	-	-	-	-	-	-	-	-	-	-	-	-	-	-	-	-	-	-	-	-	-	-	-	-	-	-

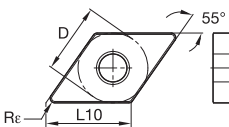
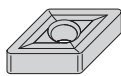

■ DNGP

目录编号	D	L10	Re	KCP05B	KCP05	KCP10B	KCP10	KCP25B	KCP25	KCP30B	KCP30	KCP40B	KCP40	KCK05B	KCK05	KGK15B	KCK15	KCK20B	KCK20	KCM15B	KCM15	KCM25B	KCM25	KCM35B	KCM35	KCPK05	K313	K68	KCU10	KCU25	KC5010	KC5025	KC5410	KT315
DNGP150401	12,70	15,50	0,1	-	-	-	-	-	-	-	-	-	-	-	-	-	-	-	-	-	-	-	-	-	-	-	-	-	-	-	-	-	-	-
DNGP150402	12,70	15,50	0,2	-	-	-	-	-	-	-	-	-	-	-	-	-	-	-	-	-	-	-	-	-	-	-	-	-	-	-	-	-	-	-
DNGP150404	12,70	15,50	0,4	-	-	-	-	-	-	-	-	-	-	-	-	-	-	-	-	-	-	-	-	-	-	-	-	-	-	-	-	-	-	-
DNGP150604	12,70	15,50	0,4	-	-	-	-	-	-	-	-	-	-	-	-	-	-	-	-	-	-	-	-	-	-	-	-	-	-	-	-	-	-	-
DNGP150408	12,70	15,50	0,8	-	-	-	-	-	-	-	-	-	-	-	-	-	-	-	-	-	-	-	-	-	-	-	-	-	-	-	-	-	-	-
DNGP150608	12,70	15,50	0,8	-	-	-	-	-	-	-	-	-	-	-	-	-	-	-	-	-	-	-	-	-	-	-	-	-	-	-	-	-	-	-

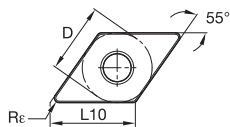
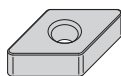
● 首选  
 ○ 备选

**DNMA**

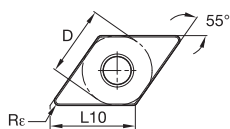
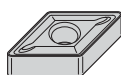
目录编号	D	L10	Re	P	M	K	N	S	H
DNMA110408	9,53	11,63	0,8	●	●	○	○		
DNMA150408	12,70	15,50	0,8	○	○	○	○		
DNMA150608	12,70	15,50	0,8	○	○	○	○		
DNMA150412	12,70	15,50	1,2	○	○	○	○		
DNMA150612	12,70	15,50	1,2	○	○	○	○		
DNMA150416	12,70	15,50	1,6	○	○	○	○		

**DNMG**

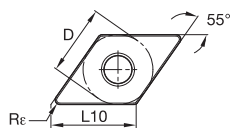
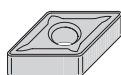
目录编号	D	L10	Re	P	M	K	N	S	H
DNMG150408B	12,70	15,50	0,8	○	○	○	○		

**DNMG-33**

目录编号	D	L10	Re	P	M	K	N	S	H
DNMG11040433	9,53	11,63	0,4	○	○	○	○		
DNMG11040833	9,53	11,63	0,8	○	○	○	○		
DNMG15060433	12,70	15,50	0,4	○	○	○	○		
DNMG15060833	12,70	15,50	0,8	○	○	○	○		



● 首选  
○ 备选

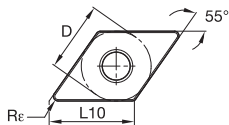
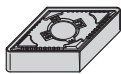

■ DNMG-FN

目录编号	D	L10	Re	KCP05B	KCP05	KCP10B	KCP10	KCP25B	KCP25	KCP30B	KCP30	KCP40B	KCP40	KCK05B	KCK05	KCK15B	KCK15	KCK20B	KCK20	KCM15B	KCM15	KCM25B	KCM25	KCM35B	KCM35	KCPK05	K313	K68	KCU10	KCU25	KC5010	KC5025	KC5410	KT315		
DNMG110404FN	9,53	11,63	0,4	-	●	-	-	-	-	-	-	-	-	-	○	-	-	-	-	-	-	-	-	-	-	-	-	-	-	-	-	-	-	-	-	
DNMG110408FN	9,53	11,63	0,8	-	●	-	-	-	-	-	-	-	-	-	○	-	-	-	-	-	-	-	-	-	-	-	-	-	-	-	-	-	-	-	-	
DNMG110412FN	9,53	11,63	1,2	-	●	-	-	-	-	-	-	-	-	-	○	-	-	-	-	-	-	-	-	-	-	-	-	-	-	-	-	-	-	-	-	
DNMG150404FN	12,70	15,50	0,4	-	●	-	-	-	-	-	-	-	-	-	○	-	-	-	-	-	-	-	-	-	-	-	-	-	-	-	-	-	-	-	-	
DNMG150604FN	12,70	15,50	0,4	-	●	-	-	-	-	-	-	-	-	-	○	-	-	-	-	-	-	-	-	-	-	-	-	-	-	-	-	-	-	-	-	
DNMG150408FN	12,70	15,50	0,8	-	●	-	-	-	-	-	-	-	-	-	○	-	-	-	-	-	-	-	-	-	-	-	-	-	-	-	-	-	-	-	-	-
DNMG150608FN	12,70	15,50	0,8	-	●	-	-	-	-	-	-	-	-	-	○	-	-	-	-	-	-	-	-	-	-	-	-	-	-	-	-	-	-	-	-	-
DNMG150412FN	12,70	15,50	1,2	-	●	-	-	-	-	-	-	-	-	-	○	-	-	-	-	-	-	-	-	-	-	-	-	-	-	-	-	-	-	-	-	-
DNMG150612FN	12,70	15,50	1,2	-	●	-	-	-	-	-	-	-	-	-	○	-	-	-	-	-	-	-	-	-	-	-	-	-	-	-	-	-	-	-	-	-

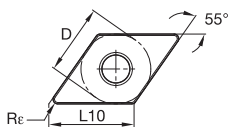
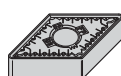

■ DNMG-FP

目录编号	D	L10	Re	KCP05B	KCP05	KCP10B	KCP10	KCP25B	KCP25	KCP30B	KCP30	KCP40B	KCP40	KCK05B	KCK05	KCK15B	KCK15	KCK20B	KCK20	KCM15B	KCM15	KCM25B	KCM25	KCM35B	KCM35	KCPK05	K313	K68	KCU10	KCU25	KC5010	KC5025	KC5410	KT315	
DNMG110404FP	9,53	11,63	0,4	-	-	-	-	-	-	-	-	-	-	-	-	-	-	-	-	-	●	●	-	-	-	-	-	-	-	-	-	-	-	-	-
DNMG110408FP	9,53	11,63	0,8	-	-	-	●	-	-	-	-	-	-	-	-	-	-	-	-	-	●	●	-	-	-	-	-	-	-	-	-	-	-	-	-
DNMG150404FP	12,70	15,50	0,4	-	-	-	-	-	-	-	-	-	-	-	-	-	-	-	-	-	●	●	-	-	-	-	-	-	-	-	-	-	-	-	-
DNMG150604FP	12,70	15,50	0,4	-	-	-	-	-	-	-	-	-	-	-	-	-	-	-	-	-	●	●	-	-	-	-	-	-	-	-	-	-	-	-	-
DNMG150408FP	12,70	15,50	0,8	-	-	-	●	-	-	-	-	-	-	-	-	-	-	-	-	-	●	●	-	-	-	-	-	-	-	-	-	-	-	-	-
DNMG150608FP	12,70	15,50	0,8	-	-	-	●	-	-	-	-	-	-	-	-	-	-	-	-	-	●	●	-	-	-	-	-	-	-	-	-	-	-	-	-
DNMG150412FP	12,70	15,50	1,2	-	-	-	-	-	-	-	-	-	-	-	-	-	-	-	-	-	●	●	-	-	-	-	-	-	-	-	-	-	-	-	-
DNMG150612FP	12,70	15,50	1,2	-	-	-	-	-	-	-	-	-	-	-	-	-	-	-	-	-	●	●	-	-	-	-	-	-	-	-	-	-	-	-	-

● 首选  
○ 备选

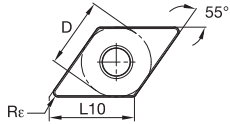
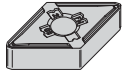

■ DNMG-FW

目录编号	D	L10	Re	KCP05B	KCP05	KCP10B	KCP10	KCP25B	KCP25	KCP30B	KCP30	KCP40B	KCP40	KCK05B	KCK05	KCK15B	KCK15	KCK20B	KCK20	KCM15B	KCM15	KCM25B	KCM25	KCM35B	KCM35	KCPK05	K313	K68	KCU10	KCU25	KC5010	KC5025	KC5410	KT315
DNMG110404FW	9,53	11,63	0,4	-	-	-	-	-	-	-	-	-	-	-	-	-	-	-	-	-	-	-	-	-	-	-	-	-	-	-	-	-	-	-
DNMG110408FW	9,53	11,63	0,8	-	●	-	-	-	-	-	-	-	-	-	-	-	-	-	-	-	-	-	-	-	-	-	-	-	-	-	-	-	-	-
DNMG150404FW	12,70	15,50	0,4	-	-	-	●	-	-	-	-	-	-	-	-	-	-	-	-	-	-	-	-	-	-	-	-	-	-	-	-	-	-	-
DNMG150408FW	12,70	15,50	0,4	-	●	-	-	-	-	-	-	-	-	-	-	-	-	-	-	-	-	-	-	-	-	-	-	-	-	-	-	-	-	-
DNMG150604FW	12,70	15,50	0,4	-	●	-	-	-	-	-	-	-	-	-	-	-	-	-	-	-	-	-	-	-	-	-	-	-	-	-	-	-	-	-
DNMG150608FW	12,70	15,50	0,4	-	●	-	-	-	-	-	-	-	-	-	-	-	-	-	-	-	-	-	-	-	-	-	-	-	-	-	-	-	-	-

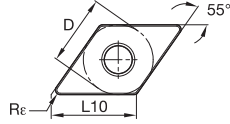
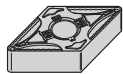

■ DNMG-MN

目录编号	D	L10	Re	KCP05B	KCP05	KCP10B	KCP10	KCP25B	KCP25	KCP30B	KCP30	KCP40B	KCP40	KCK05B	KCK05	KCK15B	KCK15	KCK20B	KCK20	KCM15B	KCM15	KCM25B	KCM25	KCM35B	KCM35	KCPK05	K313	K68	KCU10	KCU25	KC5010	KC5025	KC5410	KT315
DNMG110404MN	9,53	11,63	0,4	-	●	-	-	●	●	-	●	-	-	-	-	-	-	-	-	-	-	-	-	-	-	-	-	-	-	-	-	-	-	-
DNMG110408MN	9,53	11,63	0,8	-	●	-	-	●	●	-	●	-	-	-	-	-	-	-	-	-	-	-	-	-	-	-	-	-	-	-	-	-	-	-
DNMG110412MN	9,53	11,63	1,2	-	-	-	●	●	●	-	-	-	-	-	-	-	-	-	-	-	-	-	-	-	-	-	-	-	-	-	-	-	-	-
DNMG150404MN	12,70	15,50	0,4	-	-	-	●	●	●	-	●	-	-	-	-	-	-	-	-	-	-	-	-	-	-	-	-	-	-	-	-	-	-	-
DNMG150604MN	12,70	15,50	0,4	-	-	-	●	●	●	-	●	-	-	-	-	-	-	-	-	-	-	-	-	-	-	-	-	-	-	-	-	-	-	-
DNMG150408MN	12,70	15,50	0,8	●	-	-	●	●	●	-	●	-	-	-	-	-	-	-	-	-	-	-	-	-	-	●	-	-	-	-	-	-	-	-
DNMG150608MN	12,70	15,50	0,8	●	-	-	●	●	●	-	●	-	-	-	-	-	-	-	-	-	-	-	-	-	-	-	-	-	-	-	-	-	-	-
DNMG150412MN	12,70	15,50	1,2	-	●	-	-	●	●	-	●	-	-	-	-	-	-	-	-	-	-	-	-	-	-	-	-	-	-	-	-	-	-	-
DNMG150612MN	12,70	15,50	1,2	-	-	-	●	●	●	-	●	-	-	-	-	-	-	-	-	-	-	-	-	-	-	-	-	-	-	-	-	-	-	-
DNMG150616MN	12,70	15,50	1,6	-	-	-	●	●	●	-	●	-	-	-	-	-	-	-	-	-	-	-	-	-	-	-	-	-	-	-	-	-	-	-
DNMG190612MN	15,88	19,38	1,2	-	-	-	-	-	-	●	-	-	-	-	-	-	-	-	-	-	-	-	-	-	-	-	-	-	-	-	-	-	-	-

● 首选  
○ 备选

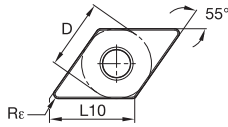

### ■ DNMG-MP

目录编号	D	L10	Re
DNMG110408MP	9,53	11,63	0,8
DNMG110412MP	9,53	11,63	1,2
DNMG150404MP	12,70	15,50	0,4
DNMG150604MP	12,70	15,50	0,4
DNMG150408MP	12,70	15,50	0,8
DNMG150608MP	12,70	15,50	0,8
DNMG150412MP	12,70	15,50	1,2
DNMG150612MP	12,70	15,50	1,2

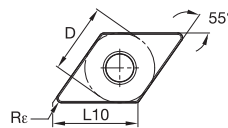
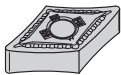

### ■ DNMG-MS

目录编号	D	L10	Re
DNMG110408MS	9,53	11,63	0,8
DNMG150401MS	12,70	15,50	0,1
DNMG150402MS	12,70	15,50	0,2
DNMG150404MS	12,70	15,50	0,4
DNMG150604MS	12,70	15,50	0,4
DNMG150408MS	12,70	15,50	0,8
DNMG150608MS	12,70	15,50	0,8
DNMG150412MS	12,70	15,50	1,2
DNMG150612MS	12,70	15,50	1,2

	P	M	K	N	S	H	KCP05B	KCP05	KCP10B	KCP10	KCP25B	KCP25	KCP30B	KCP30	KCP40B	KCP40	KCK05B	KCK05	KCK15B	KCK15	KCK20B	KCK20	KCM15B	KCM15	KCM25B	KCM25	KCM35B	KCM35	KCPK05	K313	K68	KCU10	KCU25	KC5010	KC5025	KC5410	KT315			
DNMG110408MP	●	●	●	●	●	●	●																																	
DNMG110412MP	●	●	●	●	●	●	●																																	
DNMG150404MP	○	○	○	○	○	○	○																																	
DNMG150604MP	○	○	○	○	○	○	○																																	
DNMG150408MP	●	●	●	●	●	●	●																																	
DNMG150608MP	●	●	●	●	●	●	●																																	
DNMG150412MP	○	○	○	○	○	○	○																																	
DNMG150612MP	○	○	○	○	○	○	○																																	

ISO 车削刀具

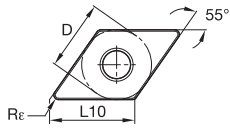
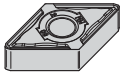

● 首选  
○ 备选

■ DNMG-MW

目录编号	D	L10	Rε	KCP05B	KCP05	KCP10B	KCP10	KCP25B	KCP25	KCP30B	KCP30	KCP40B	KCP40	KCK05B	KCK05	KCK15B	KCK15	KCK20B	KCK20	KCM15B	KCM15	KCM25B	KCM25	KCM35B	KCM35	KCPK05	K313	K68	KCU10	KCU25	KC5010	KC5025	KC5410	KT315
DNMG150408MW	12,70	15,50	0,4	-	●	●	-	-	-	-	-	-	-	-	-	-	-	-	-	-	-	-	-	-	-	-	-	-	-	-	-	-	-	-
DNMG150608MW	12,70	15,50	0,4	-	●	●	●	-	-	-	-	-	-	-	-	-	-	-	-	-	-	-	-	-	-	-	-	-	-	-	-	-	-	-
DNMG150412MW	12,70	15,50	0,8	-	●	●	-	-	-	-	-	-	-	-	-	-	-	-	-	-	-	-	-	-	-	-	-	-	-	-	-	-	-	-
DNMG150612MW	12,70	15,50	0,8	-	●	●	-	●	-	-	-	-	-	-	-	-	-	-	-	-	-	-	-	-	-	-	-	-	-	-	-	-	-	-

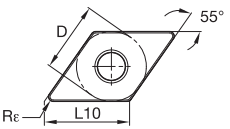
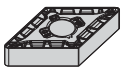

■ DNMG-MR

目录编号	D	L10	Rε	KCP05B	KCP05	KCP10B	KCP10	KCP25B	KCP25	KCP30B	KCP30	KCP40B	KCP40	KCK05B	KCK05	KCK15B	KCK15	KCK20B	KCK20	KCM15B	KCM15	KCM25B	KCM25	KCM35B	KCM35	KCPK05	K313	K68	KCU10	KCU25	KC5010	KC5025	KC5410	KT315
DNMG110408MR	9,53	11,63	0,8	-	-	●	-	●	-	-	-	-	-	-	-	-	-	-	-	-	-	-	-	-	-	-	-	-	-	-	-	-	-	-
DNMG150408MR	12,70	15,50	0,8	-	-	●	-	●	-	●	-	-	-	-	-	-	-	-	-	-	-	-	-	-	-	-	-	-	-	-	-	-	-	-
DNMG150608MR	12,70	15,50	0,8	-	-	●	-	●	-	-	-	-	-	-	-	-	-	-	-	-	-	-	-	-	-	-	-	-	-	-	-	-	-	-
DNMG150412MR	12,70	15,50	1,2	-	-	●	-	●	-	-	-	-	-	-	-	-	-	-	-	-	-	-	-	-	-	-	-	-	-	-	-	-	-	-
DNMG150612MR	12,70	15,50	1,2	-	-	●	-	●	-	-	-	-	-	-	-	-	-	-	-	-	-	-	-	-	-	-	-	-	-	-	-	-	-	-
DNMG150616MR	12,70	15,50	1,6	-	-	-	-	●	-	-	-	-	-	-	-	-	-	-	-	-	-	-	-	-	-	-	-	-	-	-	-	-	-	-

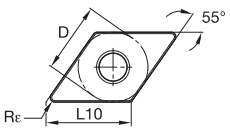
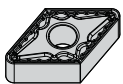

■ DNMG-MG

目录编号	D	L10	Rε	KCP05B	KCP05	KCP10B	KCP10	KCP25B	KCP25	KCP30B	KCP30	KCP40B	KCP40	KCK05B	KCK05	KCK15B	KCK15	KCK20B	KCK20	KCM15B	KCM15	KCM25B	KCM25	KCM35B	KCM35	KCPK05	K313	K68	KCU10	KCU25	KC5010	KC5025	KC5410	KT315
DNMG150612MG	12,70	15,50	1,2	-	-	●	-	-	-	-	-	-	-	-	-	-	-	-	-	-	-	-	-	-	-	-	-	-	-	-	-	-	-	-
DNMG150616MG	12,70	15,50	1,6	-	-	●	-	-	-	-	-	-	-	-	-	-	-	-	-	-	-	-	-	-	-	-	-	-	-	-	-	-	-	-





● 首选  
○ 备选

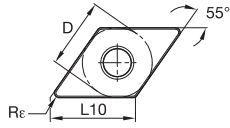

■ DNMG-UN

目录编号	D	L10	Re	KCP05B	KCP05	KCP10B	KCP10	KCP25B	KCP25	KCP30B	KCP30	KCP40B	KCP40	KCK05B	KCK05	KCK15B	KCK15	KCK20B	KCK20	KCM15B	KCM15	KCM25B	KCM25	KCM35B	KCM35	KCPK05	K313	K68	KCU10	KCU25	KC5010	KC5025	KC5410	KT315
DNMG110408UN	9,53	11,63	0,8	-	-	-	-	-	-	-	-	-	-	-	-	●	●	-	-	-	-	-	-	-	-	-	-	-	-	-	-	-	-	-
DNMG110412UN	9,53	11,63	1,2	-	-	-	-	-	-	-	-	-	-	-	-	●	●	-	-	-	-	-	-	-	-	-	-	-	-	-	-	-	-	-
DNMG150408UN	12,70	15,50	0,8	-	-	-	-	-	-	-	-	-	-	-	-	●	●	-	-	-	-	-	-	-	-	-	-	-	-	-	-	-	-	-
DNMG150608UN	12,70	15,50	0,8	-	-	-	-	-	-	-	-	-	-	-	-	●	●	-	-	-	-	-	-	-	-	-	-	-	-	-	-	-	-	-
DNMG150412UN	12,70	15,50	1,2	-	-	-	-	-	-	-	-	-	-	-	-	●	●	-	-	-	-	-	-	-	-	-	-	-	-	-	-	-	-	-
DNMG150612UN	12,70	15,50	1,2	-	-	-	-	-	-	-	-	-	-	-	-	●	●	-	-	-	-	-	-	-	-	-	-	-	-	-	-	-	-	-
DNMG150416UN	12,70	15,50	1,6	-	-	-	-	-	-	-	-	-	-	-	-	●	●	-	-	-	-	-	-	-	-	-	-	-	-	-	-	-	-	-
DNMG150616UN	12,70	15,50	1,6	-	-	-	-	-	-	-	-	-	-	-	-	●	●	-	-	-	-	-	-	-	-	-	-	-	-	-	-	-	-	-

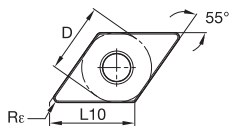
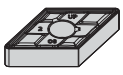

■ DNMG-UP

目录编号	D	L10	Re	KCP05B	KCP05	KCP10B	KCP10	KCP25B	KCP25	KCP30B	KCP30	KCP40B	KCP40	KCK05B	KCK05	KCK15B	KCK15	KCK20B	KCK20	KCM15B	KCM15	KCM25B	KCM25	KCM35B	KCM35	KCPK05	K313	K68	KCU10	KCU25	KC5010	KC5025	KC5410	KT315
DNMG110408UP	9,53	11,63	0,8	-	-	-	-	-	-	-	-	-	-	-	-	-	-	-	-	-	-	-	-	-	-	-	-	-	-	-	-	-	-	-
DNMG150404UP	12,70	15,50	0,4	-	-	-	-	-	-	-	-	-	-	-	-	-	-	-	-	-	-	-	-	-	-	-	-	-	-	-	-	-	-	-
DNMG150604UP	12,70	15,50	0,4	-	-	-	-	-	-	-	-	-	-	-	-	-	-	-	-	-	-	-	-	-	-	-	-	-	-	-	-	-	-	-
DNMG150408UP	12,70	15,50	0,8	-	-	-	-	-	-	-	-	-	-	-	-	-	-	-	-	-	-	-	-	-	-	-	-	-	-	-	-	-	-	-
DNMG150608UP	12,70	15,50	0,8	-	-	-	-	-	-	-	-	-	-	-	-	-	-	-	-	-	-	-	-	-	-	-	-	-	-	-	-	-	-	-

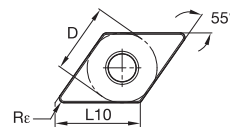
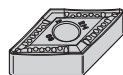

■ DNMM-RM

目录编号	D	L10	Re	KCP05B	KCP05	KCP10B	KCP10	KCP25B	KCP25	KCP30B	KCP30	KCP40B	KCP40	KCK05B	KCK05	KCK15B	KCK15	KCK20B	KCK20	KCM15B	KCM15	KCM25B	KCM25	KCM35B	KCM35	KCPK05	K313	K68	KCU10	KCU25	KC5010	KC5025	KC5410	KT315
DNMM150408RM	12,70	15,50	0,8	-	-	-	-	-	-	-	-	-	-	-	-	-	-	-	-	-	-	-	-	-	-	-	-	-	-	-	-	-	-	
DNMM150608RM	12,70	15,50	0,8	-	-	-	●	●	-	-	-	-	-	-	-	-	-	-	-	-	-	-	-	-	-	-	-	-	-	-	-	-	-	-
DNMM150412RM	12,70	15,50	1,2	-	-	-	●	●	-	-	-	-	-	-	-	-	-	-	-	-	-	-	-	-	-	-	-	-	-	-	-	-	-	-
DNMM150612RM	12,70	15,50	1,2	-	-	-	●	●	-	-	-	-	-	-	-	-	-	-	-	-	-	-	-	-	-	-	-	-	-	-	-	-	-	-
DNMM150616RM	12,70	15,50	1,6	-	-	-	●	●	-	-	-	-	-	-	-	-	-	-	-	-	-	-	-	-	-	-	-	-	-	-	-	-	-	-

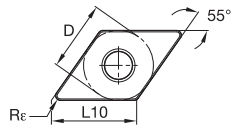
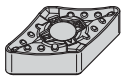
● 首选  
 ○ 备选

**DNMM-RP**

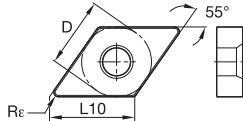
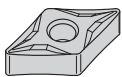
目录编号	D	L10	Re	KCP05B	KCP05	KCP10B	KCP10	KCP25B	KCP25	KCP30B	KCP30	KCP40B	KCP40	KCK05B	KCK05	KCK15B	KCK15	KCK20B	KCK20	KCM15B	KCM15	KCM25B	KCM25	KCM35B	KCM35	KCPK05	K313	K68	KCU10	KCU25	KC5010	KC5025	KC5410	KT315
DNMM150608RP	12,70	15,50	0,8	-	-	-	●	-	●	-	-	-	-	-	-	-	-	-	-	-	-	-	-	-	-	-	-	-	-	-	-	-	-	-
DNMM150612RP	12,70	15,50	1,2	-	-	●	-	●	●	-	-	-	-	-	-	-	-	-	-	-	-	-	-	-	-	-	-	-	-	-	-	-	-	-
DNMM150616RP	12,70	15,50	1,6	-	-	●	-	-	●	-	-	-	-	-	-	-	-	-	-	-	-	-	-	-	-	-	-	-	-	-	-	-	-	-

**DNMP**

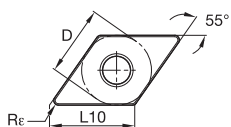
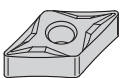
目录编号	D	L10	Re	KCP05B	KCP05	KCP10B	KCP10	KCP25B	KCP25	KCP30B	KCP30	KCP40B	KCP40	KCK05B	KCK05	KCK15B	KCK15	KCK20B	KCK20	KCM15B	KCM15	KCM25B	KCM25	KCM35B	KCM35	KCPK05	K313	K68	KCU10	KCU25	KC5010	KC5025	KC5410	KT315
DNMP150404	12,70	15,50	0,4	-	-	-	-	-	-	-	-	-	-	-	-	-	-	-	-	-	-	-	-	-	-	-	-	-	-	-	-	-	-	-
DNMP150408	12,70	15,50	0,8	-	-	-	-	-	-	-	-	-	-	-	-	-	-	-	-	-	-	-	-	-	-	-	-	-	-	-	-	-	-	-
DNMP150412	12,70	15,50	1,2	-	-	-	-	-	-	-	-	-	-	-	-	-	-	-	-	-	-	-	-	-	-	-	-	-	-	-	-	-	-	-

**DNMP-K**

目录编号	D	L10	Re	KCP05B	KCP05	KCP10B	KCP10	KCP25B	KCP25	KCP30B	KCP30	KCP40B	KCP40	KCK05B	KCK05	KCK15B	KCK15	KCK20B	KCK20	KCM15B	KCM15	KCM25B	KCM25	KCM35B	KCM35	KCPK05	K313	K68	KCU10	KCU25	KC5010	KC5025	KC5410	KT315
DNMP110408K	9,53	11,63	0,8	-	-	-	-	●	-	-	-	-	-	-	-	-	-	-	-	-	-	-	-	-	-	-	-	-	-	-	-	-	-	
DNMP150404K	12,70	15,50	0,4	-	-	-	-	●	●	-	-	-	-	-	-	-	-	-	-	-	-	-	-	-	-	-	-	-	-	-	-	-	-	-
DNMP150604K	12,70	15,50	0,4	-	-	-	-	●	●	-	-	-	-	-	-	-	-	-	-	-	-	-	-	-	-	-	-	-	-	-	-	-	-	-
DNMP150408K	12,70	15,50	0,8	-	-	●	-	-	●	-	-	-	-	-	-	-	-	-	-	-	-	-	-	-	-	-	-	-	-	-	-	-	-	-
DNMP150608K	12,70	15,50	0,8	-	-	●	-	●	●	-	-	-	-	-	-	-	-	-	-	-	-	-	-	-	-	-	-	-	-	-	-	-	-	-
DNMP150412K	12,70	15,50	1,2	-	-	●	-	-	●	-	-	-	-	-	-	-	-	-	-	-	-	-	-	-	-	-	-	-	-	-	-	-	-	-

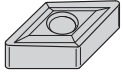

● 首选  
○ 备选

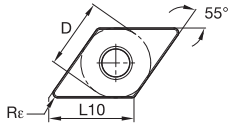

■ DNMS

目录编号	D	L10	Rr	KCP05B	KCP05	KCP10B	KCP10	KCP25B	KCP25	KCP30B	KCP30	KCP40B	KCP40	KCK05B	KCK05	KCK15B	KCK15	KCK20B	KCK20	KCM15B	KCM15	KCM25B	KCM25	KCM35B	KCM35	KCPK05	K313	K68	KCU10	KCU25	KC5010	KC5025	KCS410	KT315
DNMS150408	12,70	15,50	0,8	-	-	-	-	-	-	-	-	-	-	-	-	-	-	-	-	-	-	-	-	-	-	-	-	●	-	-	-	-	●	-

# 应用设备应用程序

肯纳公司移动应用程序，可在iPhone® 和Android™设备方便地访问产品信息。我们已经列出了的一些关键特性.....

这个应用程序给您带来便利！

- 速度和进给**  
为金属加工产品查看速度和反馈信息。
- 产品可用性**  
通过提供你的e-Konnect登录，全球范围内查看可库存的产品及数量
- 计算**  
利用计算器算出铣削和钻削的应用参数。

通过扫描刀片包装上的条形码,您可以获得的切削刀具寿命、加工时间,切屑控制的信息。



注意: 目前应用程序目前仅提供英文版本。其它语言的版本已在计划中



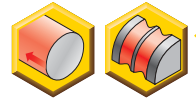
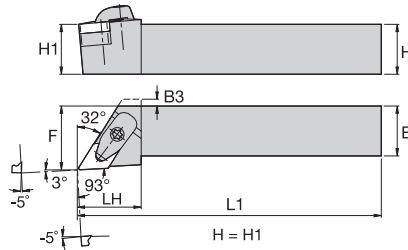
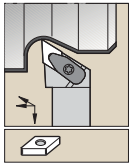

ISO 车削刀具

**■ DDJN-KC 93°**

订货号	目录编号	H	B	F	L1	LH	B3	刀片	垫片	垫片螺钉	Torx Plus 夹具装配件	Torx Plus 槽销	可选择锁定销
右手													
2273105	DDJNR2020K11KC04	20	20	25,0	125	30,0	2,0	DN..110408	IDSN322 KMSP315IP	15 IP	CM234R ASSY	15 IP	SSP025016M KLM34L9IP
1875197	DDJNR2020K15KC06	20	20	25,0	125	32,0	4,0	DN..150608	IDSN433 KMSP415IP	15 IP	CM234R ASSY	15 IP	SSP025016M KLM46L15IP
2273106	DDJNR2525M11KC04	25	25	32,0	150	30,0	—	DN..110408	IDSN322 KMSP315IP	15 IP	CM234R ASSY	15 IP	SSP025016M KLM34L9IP
1875191	DDJNR2525M15KC06	25	25	32,0	150	32,0	—	DN..150608	IDSN433 KMSP415IP	15 IP	CM234R ASSY	15 IP	SSP025016M KLM46L15IP
1875208	DDJNR3225P15KC06	32	25	32,0	170	32,0	—	DN..150608	IDSN433 KMSP415IP	15 IP	CM234R ASSY	15 IP	SSP025016M KLM46L15IP
1875227	DDJNR3232P15KC06	32	32	40,0	170	32,0	—	DN..150608	IDSN433 KMSP415IP	15 IP	CM234R ASSY	15 IP	SSP025016M KLM46L15IP
左手													
2273107	DDJNL2020K11KC04	20	20	25,0	125	30,0	2,0	DN..110408	IDSN322 KMSP315IP	15 IP	CM234R ASSY	15 IP	SSP025016M KLM34L9IP
1875198	DDJNL2020K15KC06	20	20	25,0	125	32,0	4,0	DN..150608	IDSN433 KMSP415IP	15 IP	CM234R ASSY	15 IP	SSP025016M KLM46L15IP
2273108	DDJNL2525M11KC04	25	25	32,0	150	30,0	—	DN..110408	IDSN322 KMSP315IP	15 IP	CM234R ASSY	15 IP	SSP025016M KLM34L9IP
1875192	DDJNL2525M15KC06	25	25	32,0	150	32,0	—	DN..150608	IDSN433 KMSP415IP	15 IP	CM234R ASSY	15 IP	SSP025016M KLM46L15IP
1875207	DDJNL3225P15KC06	32	25	32,0	170	32,0	—	DN..150608	IDSN433 KMSP415IP	15 IP	CM234R ASSY	15 IP	SSP025016M KLM46L15IP
1875209	DDJNL3232P15KC06	32	32	40,0	171	32,0	—	DN..150608	IDSN433 KMSP415IP	15 IP	CM234R ASSY	15 IP	SSP025016M KLM46L15IP

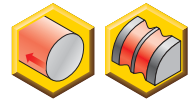
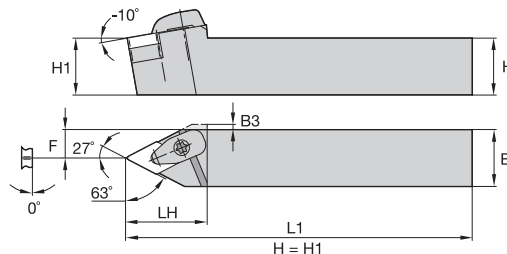
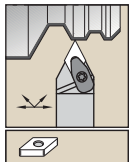
**■ DDNN-KC 63°**

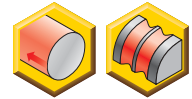
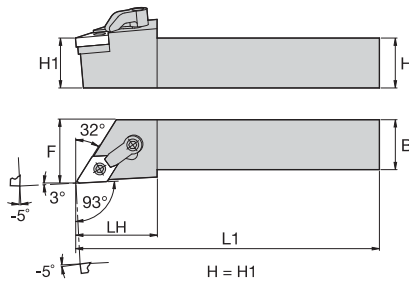
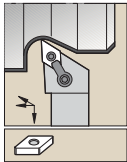

订货号	目录编号	H	B	F	L1	LH	B3	刀片	垫片	垫片螺钉	Torx Plus 夹具装配件	Torx Plus 槽销	可选择锁定销
右手													
2273111	DDNNR2020K15KC06	20	20	10,0	125	40,0	2,5	DN..150608	IDSN433 KMSP415IP	15 IP	CM234R ASSY	15 IP	SSP025016M KLM46L15IP
2273112	DDNNR2525M15KC06	25	25	13,0	150	40,0	—	DN..150608	IDSN433 KMSP415IP	15 IP	CM234R ASSY	15 IP	SSP025016M KLM46L15IP



■ MDJN 93°

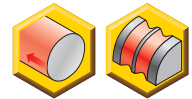
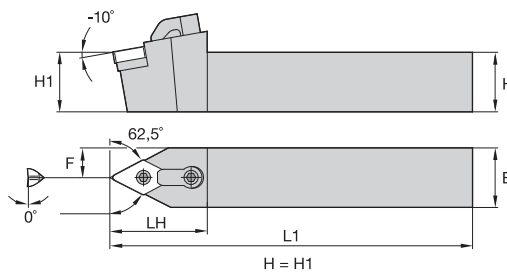
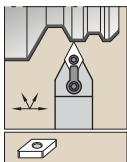

订货号	目录编号	H	B	F	L1	LH	刀片	垫片	锁销	六角	夹具	夹紧螺钉	六角
右手													
1100936	MDJNR1616H11	16	16	20,0	100	32,0	DN..110408	IDSN322	KLM34L	2 mm	CKM7	STCM5	2.5 mm
1101286	MDJNR2020K11	20	20	25,0	125	32,0	DN..110408	IDSN322	KLM34L	2 mm	CKM7	STCM5	2.5 mm
1101356	MDJNR2020K15	20	20	25,0	125	36,0	DN..150608	IDSN432	KLM46L	2.5 mm	CKM22	STCM20	3 mm
1101288	MDJNR2525M11	25	25	32,0	150	32,0	DN..110408	IDSN322	KLM34L	2 mm	CKM7	STCM5	2.5 mm
1101357	MDJNR2525M15	25	25	32,0	150	36,0	DN..150608	IDSN432	KLM46L	2.5 mm	CKM22	STCM20	3 mm
1101358	MDJNR3225P15	32	25	32,0	170	36,0	DN..150608	IDSN432	KLM46L	2.5 mm	CKM22	STCM20	3 mm
3638550	MDJNR3232P15	32	32	40,5	173	32,0	DN..150608	IDSN432	KLM46L	2.5 mm	CKM22	STCM20	3 mm
左手													
1101285	MDJNL2020K11	20	20	25,0	125	32,0	DN..110408	IDSN322	KLM34L	2 mm	CKM7	STCM5	2.5 mm
1101287	MDJNL2525M11	25	25	32,0	150	32,0	DN..110408	IDSN322	KLM34L	2 mm	CKM7	STCM5	2.5 mm
1102316	MDJNL2525M15	25	25	32,0	150	36,0	DN..150608	IDSN432	KLM46L	2.5 mm	CKM22	STCM20	3 mm
1102317	MDJNL3225P15	32	25	32,0	170	32,0	DN..150608	IDSN432	KLM46L	2.5 mm	CKM22	STCM20	3 mm
3638551	MDJNL3232P15	32	32	40,5	173	32,0	DN..150608	IDSN432	KLM46L	2.5 mm	CKM22	STCM20	3 mm



■ MDNN 62,5°



订货号	目录编号	H	B	F	L1	LH	刀片	垫片	锁销	六角	夹具	夹紧螺钉	六角
右手													
1101636	MDNNR2525M15	68	25	12,5	150	41,0	DN..150608	IDSN432	KLM46L	2.5 mm	CKM22	STCM20	3 mm
1101637	MDNNR3225P15	88	32	12,5	170	41,0	DN..150608	IDSN432	KLM46L	2.5 mm	CKM22	STCM20	3 mm
左手													
1102434	MDNNL2525M15	68	25	12,5	150	41,0	DN..150608	IDSN432	KLM46L	2.5 mm	CKM22	STCM20	3 mm
1102435	MDNNL3225P15	88	32	12,5	170	41,0	DN..150608	IDSN432	KLM46L	2.5 mm	CKM22	STCM20	3 mm

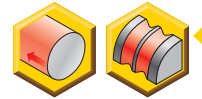
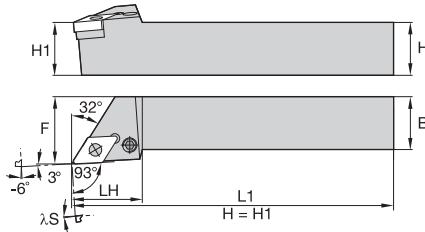
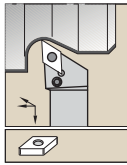

ISO 车削刀具

**■ PDJN 93°**

订货号	目录编号	H	B	F	L1	LH	λS°	刀片	垫片	垫片销	冲头	杠杆	杠杆螺钉	Torx Plus
右手														
1244752	PDJNR1616H11	16	16	20,0	100	24,0	-6,0	DN..110408	512.060	513.060	515.018	511.060	514.118	10 IP
1192382	PDJNR2020K11	20	20	25,0	125	30,0	-7,0	DN..110408	512.060	513.060	515.018	511.060	514.118	10 IP
1192383	PDJNR2020K15	20	20	25,0	125	36,0	-7,0	DN..150608	512.153	513.023	515.018	511.024	514.128	15 IP
1192384	PDJNR2525M11	25	25	32,0	150	30,0	-7,0	DN..110408	512.060	513.060	515.018	511.060	514.118	10 IP
1192385	PDJNR2525M15	25	25	32,0	150	36,0	-7,0	DN..150608	512.153	513.023	515.018	511.024	514.128	15 IP
1156969	PDJNR3225P15	32	25	32,0	170	36,0	-7,0	DN..150608	512.153	513.023	515.018	511.024	514.128	15 IP
1236865	PDJNR3232P15	32	32	40,0	170	36,0	-7,0	DN..150608	512.153	513.023	515.018	511.024	514.128	15 IP
1244784	PDJNR4025R15	40	25	32,0	200	36,0	-7,0	DN..150608	512.153	513.023	515.018	511.024	514.128	15 IP
左手														
1244751	PDJNL1616H11	16	16	20,0	100	24,0	-6,0	DN..110408	512.060	513.060	515.018	511.060	514.118	10 IP
1244658	PDJNL2020K11	20	20	25,0	125	30,0	-7,0	DN..110408	512.060	513.060	515.018	511.060	514.118	10 IP
1244820	PDJNL2020K15	20	20	25,0	125	36,0	-7,0	DN..150608	512.153	513.023	515.018	511.024	514.128	15 IP
1192380	PDJNL2525M11	25	25	32,0	150	30,0	-7,0	DN..110408	512.060	513.060	515.018	511.060	514.118	10 IP
1156968	PDJNL2525M15	25	25	32,0	150	36,0	-7,0	DN..150608	512.153	513.023	515.018	511.024	514.128	15 IP
1244781	PDJNL3225P15	32	25	32,0	170	36,0	-7,0	DN..150608	512.153	513.023	515.018	511.024	514.128	15 IP
1244821	PDJNL3232P15	32	32	40,0	170	36,0	-7,0	DN..150608	512.153	513.023	515.018	511.024	514.128	15 IP
1192381	PDJNL4025R15	40	25	32,0	200	36,0	-7,0	DN..150608	512.153	513.023	515.018	511.024	514.128	15 IP

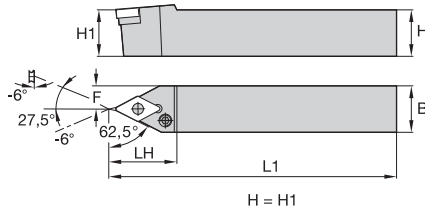
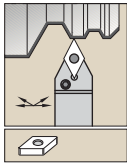

■ PDNN 62,5°

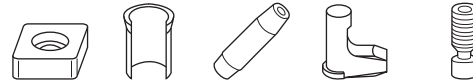

订货号	目录编号	H	B	F	L1	LH	刀片	垫片	垫片销	冲头	杠杆	杠杆螺钉	Torx Plus
右手													
1244756	PDNNR2020K11	20	20	10,0	125	24,0	DN..110408	512.060	513.060	515.018	511.060	514.118	10 IP
1244824	PDNNR2020K15	20	20	10,0	125	36,0	DN..150608	512.153	513.023	515.018	511.024	514.128	15 IP
1244773	PDNNR2525M15	25	25	12,5	150	36,0	DN..150608	512.153	513.023	515.018	511.024	514.128	15 IP
1244825	PDNNR4025M15	40	25	12,5	150	36,0	DN..150608	512.153	513.023	515.018	511.024	514.128	15 IP
左手													
1244754	PDNNL2020K11	20	20	10,0	125	24,0	DN..110408	512.060	513.060	515.018	511.060	514.118	10 IP
1244822	PDNNL2020K15	20	20	10,0	125	36,0	DN..150608	512.153	513.023	515.018	511.024	514.128	15 IP
1244659	PDNNL2525M11	25	25	12,5	150	30,0	DN..110408	512.060	513.060	515.018	511.060	514.118	10 IP
1244785	PDNNL2525M15	25	25	12,5	150	36,0	DN..150608	512.153	513.023	515.018	511.024	514.128	15 IP
1244823	PDNNL4025M15	40	25	12,5	150	36,0	DN..150608	512.153	513.023	515.018	511.024	514.128	15 IP



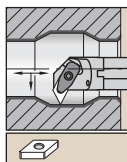
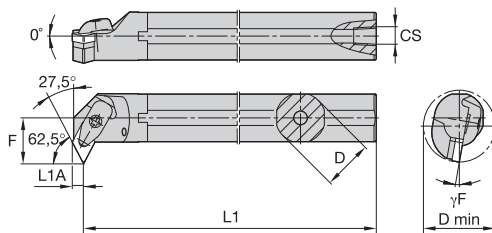

 带有内冷的  
 钢刀柄。

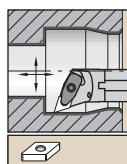
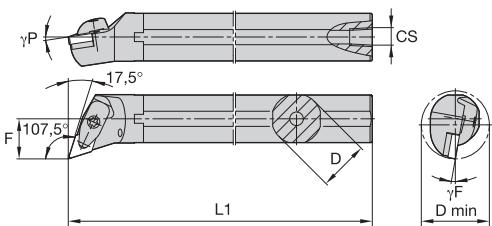
**A-DDPN-KC 117,5°**

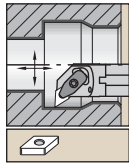

订货号	目录编号	D	D min	F	L1	L1A	CS	γF°	刀片	垫片	垫片螺钉	Torx Plus	夹具装配件	槽销	Torx Plus
<b>右手</b>															
2441957	A25RDDPNR11KC04	25	37,0	22,0	200	4,8	1/4-18 NPT	-10,0	DN..110408	IDSN322	KMSP315IP	15 IP	CM234R ASSY	SSP025016M	15 IP
2441959	A32SDDPNR15KC06	32	45,0	27,0	250	6,5	1/4-18 NPT	-12,0	DN..150608	IDSN433	KMSP415IP	15 IP	CM234R ASSY	SSP025016M	15 IP
2441961	A40TDDPNR15KC06	40	52,0	30,0	300	6,6	1/4-18 NPT	-10,0	DN..150608	IDSN433	KMSP415IP	15 IP	CM234R ASSY	SSP025016M	15 IP
<b>左手</b>															
2441960	A32SDDPNL15KC06	32	45,0	27,0	250	—	1/4-18 NPT	-12,0	DN..150608	IDSN433	KMSP415IP	15 IP	CM234R ASSY	SSP025016M	15 IP
2441962	A40TDDPNL15KC06	40	52,0	30,0	300	6,6	1/4-18 NPT	-10,0	DN..150608	IDSN433	KMSP415IP	15 IP	CM234R ASSY	SSP025016M	15 IP

 带有内冷  
 的钢刀柄。

**A-DDQN-KC 107,5°**

订货号	目录编号	D	D min	F	L1	CS	γF°	γP°	刀片	垫片	垫片螺钉	Torx Plus	夹具装配件	槽销	Torx Plus
<b>右手</b>															
2441951	A25RDDQNR11KC04	25	32,0	17,0	200	1/4-18 NPT	-11,0	-7,0	DN..110408	—	—	—	CM234R ASSY	SSP025016M	15 IP
2441953	A32SDDQNR15KC06	32	40,0	22,0	250	1/4-18 NPT	-12,0	-10,0	DN..150608	IDSN433	KMSP415IP	15 IP	CM234R ASSY	SSP025016M	15 IP
2441955	A40TDDQNR15KC06	40	50,0	27,0	300	1/4-18 NPT	-10,0	-10,0	DN..150608	IDSN433	KMSP415IP	15 IP	CM234R ASSY	SSP025016M	15 IP
<b>左手</b>															
2441952	A25RDDQNL11KC04	25	32,0	17,0	200	1/4-18 NPT	-11,0	-7,0	DN..110408	—	—	—	CM234R ASSY	SSP025016M	15 IP
2441954	A32SDDQNL15KC06	32	40,0	22,0	250	1/4-18 NPT	-12,0	-10,0	DN..150608	IDSN433	KMSP415IP	15 IP	CM234R ASSY	SSP025016M	15 IP
2441956	A40TDDQNL15KC06	40	50,0	27,0	300	1/4-18 NPT	-10,0	-10,0	DN..150608	IDSN433	KMSP415IP	15 IP	CM234R ASSY	SSP025016M	15 IP

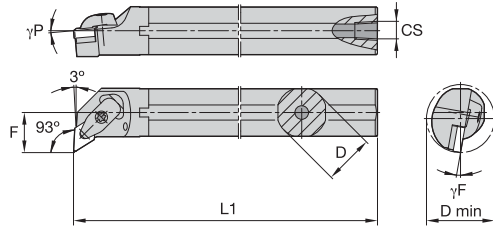

带有内冷的钢刀柄。



■ A-DDUN-KC 93°



订货号	目录编号	D	D min	F	L1	CS	γF°	γP°	刀片	垫片	垫片螺钉	Torx Plus	夹具装配件	槽销	Torx Plus
右手															
2441939	A25RDDUNR11KC04	25	32,0	17,0	200	1/4-18 NPT	-12,0	-5,0	DN..110408	—	—	—	CM234R ASSY	SSP025016M	15 IP
2441941	A32SDDUNR11KC04	32	40,0	22,0	250	1/4-18 NPT	-12,0	-5,0	DN..110408	IDSN322	KMSP315IP	15 IP	CM234R ASSY	SSP025016M	15 IP
2441945	A32SDDUNR15KC06	32	40,0	22,0	250	1/4-18 NPT	-12,0	-6,0	DN..150608	IDSN433	KMSP415IP	15 IP	CM234R ASSY	SSP025016M	15 IP
2441947	A40TDDUNR15KC06	40	50,0	27,0	300	1/4-18 NPT	-9,0	-5,0	DN..150608	IDSN433	KMSP415IP	15 IP	CM234R ASSY	SSP025016M	15 IP
2441949	A50UDDUNR15KC06	50	63,0	35,0	350	1/4-18 NPT	-7,0	-5,0	DN..150608	IDSN433	KMSP415IP	15 IP	CM234R ASSY	SSP025016M	15 IP
左手															
2441940	A25RDUNL11KC04	25	32,0	17,0	200	1/4-18 NPT	-12,0	-5,0	DN..110408	—	—	—	CM234R ASSY	SSP025016M	15 IP
2441942	A32SDUNL11KC04	32	40,0	22,0	250	1/4-18 NPT	-12,0	-5,0	DN..110408	IDSN322	KMSP315IP	15 IP	CM234R ASSY	SSP025016M	15 IP
2441946	A32SDUNL15KC06	32	40,0	22,0	250	1/4-18 NPT	-12,0	-6,0	DN..150608	IDSN433	KMSP415IP	15 IP	CM234R ASSY	SSP025016M	15 IP
2441948	A40TDUNL15KC06	40	50,0	27,0	300	1/4-18 NPT	-9,0	-5,0	DN..150608	IDSN433	KMSP415IP	15 IP	CM234R ASSY	SSP025016M	15 IP
2441950	A50UDUNL15KC06	50	63,0	35,0	350	1/4-18 NPT	-7,0	-5,0	DN..150608	IDSN433	KMSP415IP	15 IP	CM234R ASSY	SSP025016M	15 IP

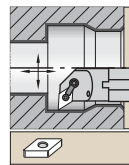

带有内冷的钢刀柄。

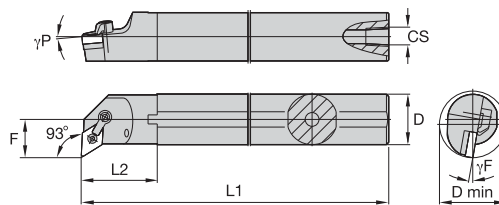

■ A-MDUN 93°



订货号	目录编号	D	D min	F	L1	L2	CS	γF°	γP°	刀片	垫片	锁销	六角	夹具	夹紧螺钉	六角
右手																
1098769	A25RMDUNR11	25	32,0	17,0	200	40,0	1/4-18 NPT	-14,0	-5,0	DN..110408	—	KLM33L	2 mm	CKM7	STCM5	2.5 mm
1098102	A25RMDUNR15	25	32,0	17,0	200	—	1/4-18 NPT	-14,0	-5,0	DN..150408	IDSN432	KLM46L	2.5 mm	CKM22	STCM11	3 mm
1098770	A32SMDUNR11	32	40,0	22,0	250	50,0	1/4-18 NPT	-12,0	-5,0	DN..110408	IDSN322	KLM34L	2 mm	CKM7	STCM5	2.5 mm
1098104	A32SMDUNR15	32	40,0	22,0	250	—	1/4-18 NPT	-12,0	-6,0	DN..150608	IDSN432	KLM46L	2.5 mm	CKM22	STCM20	3 mm
1098106	A40TMDUNR15	40	50,0	27,0	300	—	1/4-18 NPT	-9,0	-5,0	DN..150608	IDSN432	KLM46L	2.5 mm	CKM22	STCM20	3 mm
1098108	A50UMDUNR15	50	63,0	35,0	350	—	1/4-18 NPT	-7,0	-5,0	DN..150608	IDSN432	KLM46L	2.5 mm	CKM22	STCM20	3 mm
左手																
1098779	A25RMDUNL11	25	32,0	17,0	200	40,0	1/4-18 NPT	-14,0	-5,0	DN..110408	—	KLM33L	2 mm	CKM7	STCM5	2.5 mm
1098103	A25RMDUNL15	25	32,0	17,0	200	—	1/4-18 NPT	-14,0	-5,0	DN..150408	IDSN432	KLM46L	2.5 mm	CKM22	STCM11	3 mm
1098780	A32SMDUNL11	32	40,0	22,0	250	50,0	1/4-18 NPT	-12,0	-5,0	DN..110408	IDSN322	KLM34L	2 mm	CKM7	STCM5	2.5 mm
1098105	A32SMDUNL15	32	40,0	22,0	250	—	1/4-18 NPT	-12,0	-6,0	DN..150608	IDSN432	KLM46L	2.5 mm	CKM22	STCM20	3 mm
1098107	A40TMDUNL15	40	50,0	27,0	300	—	1/4-18 NPT	-9,0	-5,0	DN..150608	IDSN432	KLM46L	2.5 mm	CKM22	STCM20	3 mm
1098109	A50UMDUNL15	50	63,0	35,0	350	—	1/4-18 NPT	-7,0	-5,0	DN..150608	IDSN432	KLM46L	2.5 mm	CKM22	STCM20	3 mm

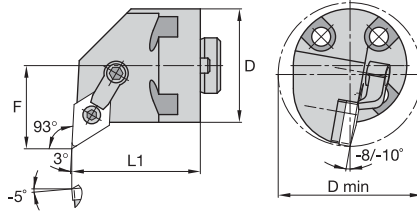

带有内冷。

**■ H-MDUN 93°**

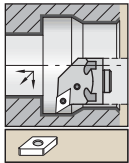

订货号	目录编号	D	D min	F	L1	刀片	垫片	锁销	六角	夹具	夹紧螺钉	六角
右手												
1099094	H40MDUNR15	40	50,0	27,0	41	DN..150608	IDSN432	KLM46L	2.5 mm	CKM22	STCM20	3 mm
左手												
3612192	H50MDUNL19	50	63,0	35,0	41	DN..190612	IDSN533	KLM58	3 mm	CKM12	STCM4	4 mm

**Kenlever™ 镗头**

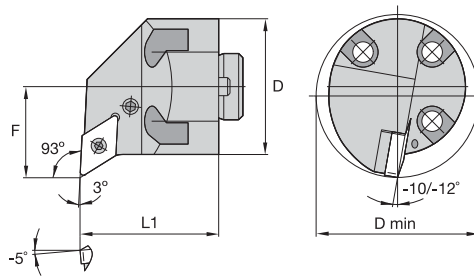
带内冷功能。

**■ H-PDUN 93°**

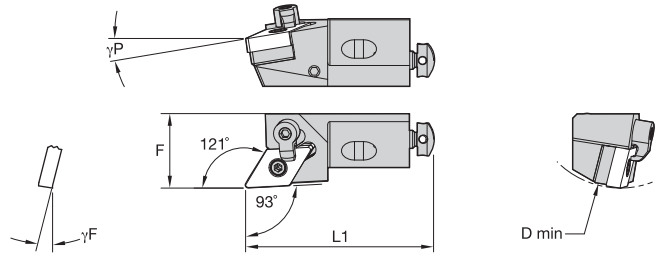
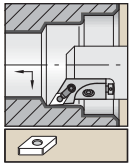
订货号	目录编号	D	D min	F	L1	刀片	垫片	垫片销	销	杠杆	杠杆螺钉	Torx Plus
右手												
1861496	H32PDUNR15	32	43,0	25,0	41	DN..150608	512.153	513.023	515.018	511.024	514.128	15 IP
1861519	H50PDUNR15	50	63,0	35,0	41	DN..150608	512.153	513.023	515.018	511.024	514.128	15 IP
左手												
1861520	H50PDUNL15	50	63,0	35,0	41	DN..150608	512.153	513.023	515.018	511.024	514.128	15 IP



■ MDJN 93°

订货号	目录编号	D min	F	L1	γF°	γP°	刀片
<b>右手</b>							
3346241	MDJNR12CA11	50	20,0	55	-9.0	-9.0	DN..110408/DN..322
3330275	MDJNR16CA15	60	25,0	63	-9.0	-9.0	DN..150408/DN..432
3330199	MDJNR20CA15	70	25,0	70	-8.5	-8.5	DN..150408/DN..3.532
<b>左手</b>							
3346240	MDJNL12CA11	50	20,0	55	-9.0	-9.0	DN..110408/DN..322
3330274	MDJNL16CA15	60	25,0	63	-9.0	-9.0	DN..150408/DN..432

■ 配件



D min	垫片	锁销	六角	夹具	夹紧螺钉	六角	径向调节螺钉	六角	轴向调整螺钉	安装螺钉	六角	垫片
50	—	KLM33L	2 mm	CKM34	STCM38	2 mm	KUAM22	2 mm	KUAM31	191.406	4 mm	CSWM 060 050
60	IDSN432	KLM46S	2.5 mm	CKM36	STCM9	2.5 mm	KUAM25	2.5 mm	KUAM32	191.407	5 mm	CSWM 080 050
70	IDSN432	KLM46	2.5 mm	CKM41	STCM40	2.5 mm	KUAM25	2.5 mm	KUAM32	191.407	5 mm	CSWM 080 050

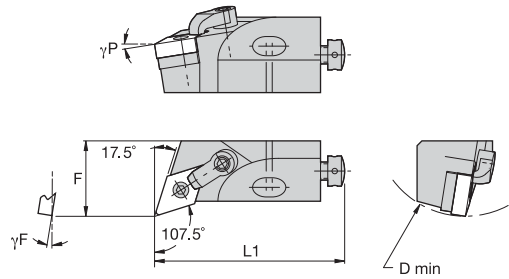

**MDQN 107,5°**

订货号	目录编号	D min	F	L1	$\gamma_F^\circ$	$\gamma_P^\circ$	刀片
<b>右手</b>							
3330277	MDQNR16CA15	60	25,0	63	-9.0	-6.0	DN..150408/DN..432
3330201	MDQNR20CA15	70	25,0	70	-9.0	-8.0	DN..150408/DN..432
<b>左手</b>							
3330276	MDQNL16CA15	60	25,0	63	-9.0	-6.0	DN..150408/DN..432
3330200	MDQNL20CA15	70	25,0	70	-9.0	-8.0	DN..150408/DN..432

**配件**

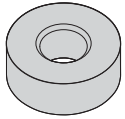

D min	垫片	锁销	六角	夹具	夹紧螺钉	六角	径向调节螺钉	六角	轴向调整螺钉	安装螺钉	六角	垫片
60	IDSN432	KLM46S	2.5 mm	CKM36	STCM9	2.5 mm	KUAM25	2.5 mm	KUAM32	191.407	5 mm	CSWM 080 050
70	IDSN432	KLM46	2.5 mm	CKM34	STCM9	2.5 mm	KUAM25	2.5 mm	KUAM32	191.407	5 mm	CSWM 080 050

● 首选  
○ 备选

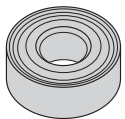

■ RNMA

目录编号	D	L10	Re	KCP05B	KCP05	KCP10B	KCP10	KCP25B	KCP25	KCP30B	KCP30	KCP40B	KCP40	KCK05B	KCK05	KCK15B	KCK15	KCK20B	KCK20	KCM15B	KCM15	KCM25B	KCM25	KCM35B	KCM35	KCPK05	K313	K68	KCU10	KCU25	KC5010	KC5025	KC5410	KT315
RNMA120400	12,70	-	-	-	-	-	-	-	-	-	-	-	-	-	-	-	-	-	-	-	-	-	-	-	-	-	-	-	-	-	-	-	-	-
RNMA150600	15,88	-	-	-	-	-	-	-	-	-	-	-	-	-	-	-	-	-	-	-	-	-	-	-	-	-	-	-	-	-	-	-	-	-



■ RNMG

目录编号	D	L10	Re	KCP05B	KCP05	KCP10B	KCP10	KCP25B	KCP25	KCP30B	KCP30	KCP40B	KCP40	KCK05B	KCK05	KCK15B	KCK15	KCK20B	KCK20	KCM15B	KCM15	KCM25B	KCM25	KCM35B	KCM35	KCPK05	K313	K68	KCU10	KCU25	KC5010	KC5025	KC5410	KT315
RNMG190600	19,05	-	-	-	-	-	-	-	●	-	-	-	-	●	-	-	-	-	-	-	-	-	-	-	-	-	●	-	-	-	-	-	-	-

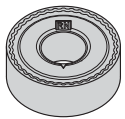

■ RNMG-RN

目录编号	D	L10	Re	KCP05B	KCP05	KCP10B	KCP10	KCP25B	KCP25	KCP30B	KCP30	KCP40B	KCP40	KCK05B	KCK05	KCK15B	KCK15	KCK20B	KCK20	KCM15B	KCM15	KCM25B	KCM25	KCM35B	KCM35	KCPK05	K313	K68	KCU10	KCU25	KC5010	KC5025	KC5410	KT315
RNMG090300RN	9,53	-	-	-	-	-	-	●	●	-	-	-	-	-	-	-	-	-	-	-	-	-	-	-	-	-	-	-	-	-	-	-	-	
RNMG120400RN	12,70	-	-	-	-	-	●	●	●	-	-	-	-	-	-	-	-	-	-	-	-	-	-	-	-	-	-	-	-	-	-	-	-	-
RNMG150600RN	15,88	-	-	-	-	-	-	●	●	-	-	-	-	-	-	-	-	-	-	-	-	-	-	-	-	-	-	-	-	-	-	-	-	-
RNMG190600RN	19,05	-	-	-	-	-	-	●	●	-	-	-	-	-	-	-	-	-	-	-	-	-	-	-	-	-	-	-	-	-	-	-	-	-
RNMG250900RN	25,40	-	-	-	-	-	-	●	●	-	-	-	-	-	-	-	-	-	-	-	-	-	-	-	-	-	-	-	-	-	-	-	-	-

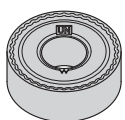

■ RNMG-UN

目录编号	D	L10	Re	KCP05B	KCP05	KCP10B	KCP10	KCP25B	KCP25	KCP30B	KCP30	KCP40B	KCP40	KCK05B	KCK05	KCK15B	KCK15	KCK20B	KCK20	KCM15B	KCM15	KCM25B	KCM25	KCM35B	KCM35	KCPK05	K313	K68	KCU10	KCU25	KC5010	KC5025	KC5410	KT315
RNMG120400UN	12,70	-	-	-	-	-	-	-	-	-	-	-	-	-	-	-	-	-	-	-	-	-	-	-	-	-	-	-	-	-	-	-	-	-

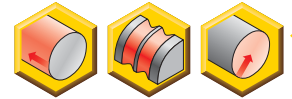
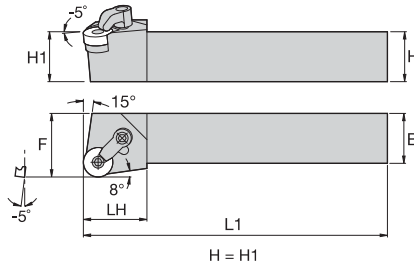
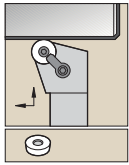

ISO 车削刀具

■ MRGN



订货号	目录编号	H	B	F	L1	LH	刀片	垫片	锁销	六角	夹具	夹紧螺钉	六角
右手													
1102086	MRGNR2525M12	25	25	32,0	150	32,0	RN..120400	IRSN43	KLM46	2.5 mm	CKM21	STCM20	3 mm
左手													
1102699	MRGNL2525M12	25	25	32,0	150	32,0	RN..120400	IRSN43	KLM46	2.5 mm	CKM21	STCM20	3 mm

ISO 车削刀具

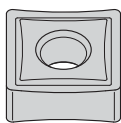

- 首选
- 备选

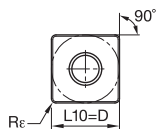

■ SNGP

目录编号	D	L10	Rε	KCP05B	KCP05	KCP10B	KCP10	KCP25B	KCP25	KCP30B	KCP30	KCP40B	KCP40	KCK05B	KCK05	KCK15B	KCK15	KCK20B	KCK20	KCM15B	KCM15	KCM25B	KCM25	KCM35B	KCM35	KCPK05	K313	K68	KCU10	KCU25	KC5010	KC5025	KC5410	KT315
SNGP120404	12,70	12,70	0,4	-	●	-	-	-	-	-	-	-	-	-	-	-	-	-	-	-	-	-	-	-	-	-	-	-	-	-	-	-	-	-
SNGP120408	12,70	12,70	0,8	-	●	-	-	-	-	-	-	-	-	-	-	-	-	-	-	-	-	-	-	-	-	-	-	-	-	-	-	-	-	-

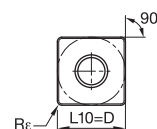
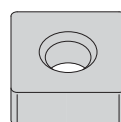

■ SNMA

目录编号	D	L10	Rε	KCP05B	KCP05	KCP10B	KCP10	KCP25B	KCP25	KCP30B	KCP30	KCP40B	KCP40	KCK05B	KCK05	KCK15B	KCK15	KCK20B	KCK20	KCM15B	KCM15	KCM25B	KCM25	KCM35B	KCM35	KCPK05	K313	K68	KCU10	KCU25	KC5010	KC5025	KC5410	KT315
SNMA120408	12,70	12,70	0,8	-	-	-	-	-	-	-	-	-	-	-	-	-	-	-	-	-	-	-	-	-	-	-	-	-	-	-	-	-	-	
SNMA120412	12,70	12,70	1,2	-	-	-	-	-	-	-	-	-	-	-	-	-	-	-	-	-	-	-	-	-	-	-	-	-	-	-	-	-	-	
SNMA150612	15,88	15,88	1,2	-	-	-	-	-	-	-	-	-	-	-	-	-	-	-	-	-	-	-	-	-	-	-	-	-	-	-	-	-	-	
SNMA190612	19,05	19,05	1,2	-	-	-	-	-	-	-	-	-	-	-	-	-	-	-	-	-	-	-	-	-	-	-	-	-	-	-	-	-	-	
SNMA190616	19,05	19,05	1,6	-	-	-	-	-	-	-	-	-	-	-	-	-	-	-	-	-	-	-	-	-	-	-	-	-	-	-	-	-	-	

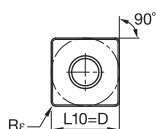
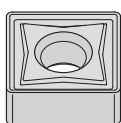

■ SNMG

目录编号	D	L10	Rε	KCP05B	KCP05	KCP10B	KCP10	KCP25B	KCP25	KCP30B	KCP30	KCP40B	KCP40	KCK05B	KCK05	KCK15B	KCK15	KCK20B	KCK20	KCM15B	KCM15	KCM25B	KCM25	KCM35B	KCM35	KCPK05	K313	K68	KCU10	KCU25	KC5010	KC5025	KC5410	KT315
SNMG120408	12,70	12,70	0,8	-	-	-	-	-	-	-	-	-	-	-	-	-	-	-	-	-	-	-	-	-	-	-	-	-	-	-	-	-	-	
SNMG120412	12,70	12,70	1,2	-	-	-	-	-	-	-	-	-	-	-	-	-	-	-	-	-	-	-	-	-	-	-	-	-	-	-	-	-	-	
SNMG190612	19,05	19,05	1,2	-	-	-	-	-	-	-	-	-	-	-	-	-	-	-	-	-	-	-	-	-	-	-	-	-	-	-	-	-	-	
SNMG190616	19,05	19,05	1,6	-	-	-	-	-	-	-	-	-	-	-	-	-	-	-	-	-	-	-	-	-	-	-	-	-	-	-	-	-	-	
SNMG250924	25,40	25,40	2,4	-	-	-	-	●	-	-	-	-	-	-	-	-	-	-	-	-	-	-	-	-	-	-	-	-	-	-	-	-	-	







● 首选  
○ 备选

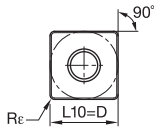
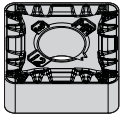

■ SNMG-MR

目录编号	D	L10	Rε	KCP05B	KCP05	KCP10B	KCP10	KCP25B	KCP25	KCP30B	KCP30	KCP40B	KCP40	KCK05B	KCK05	KCK15B	KCK15	KCK20B	KCK20	KCM15B	KCM15	KCM25B	KCM25	KCM35B	KCM35	KCPK05	K313	K68	KCU10	KCU25	KC5010	KC5025	KC5410	KT315
SNMG120408MR	12,70	12,70	0,8	-	-	-	-	●	-	-	-	-	-	-	-	-	-	-	-	-	-	●	-	-	-	-	-	-	-	-	-	-	-	-
SNMG120412MR	12,70	12,70	1,2	-	-	●	-	●	-	-	-	-	-	-	-	-	-	-	-	-	-	-	●	-	-	-	-	-	-	-	-	-	-	-
SNMG150612MR	15,88	15,88	1,2	-	-	-	-	-	-	-	-	-	-	-	-	-	-	-	-	-	●	-	-	-	-	●	-	-	-	-	-	-	-	-

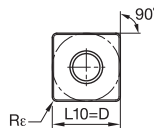
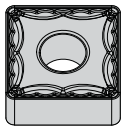

■ SNMG-MG

目录编号	D	L10	Rε	KCP05B	KCP05	KCP10B	KCP10	KCP25B	KCP25	KCP30B	KCP30	KCP40B	KCP40	KCK05B	KCK05	KCK15B	KCK15	KCK20B	KCK20	KCM15B	KCM15	KCM25B	KCM25	KCM35B	KCM35	KCPK05	K313	K68	KCU10	KCU25	KC5010	KC5025	KC5410	KT315
SNMG120416MG	12,70	12,70	1,6	-	-	-	-	●	-	-	-	-	-	-	-	-	-	-	-	-	-	-	-	-	-	-	-	-	-	-	-	-	-	-

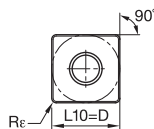
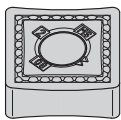

■ SNMG-MS

目录编号	D	L10	Rε	KCP05B	KCP05	KCP10B	KCP10	KCP25B	KCP25	KCP30B	KCP30	KCP40B	KCP40	KCK05B	KCK05	KCK15B	KCK15	KCK20B	KCK20	KCM15B	KCM15	KCM25B	KCM25	KCM35B	KCM35	KCPK05	K313	K68	KCU10	KCU25	KC5010	KC5025	KC5410	KT315
SNMG120408MS	12,70	12,70	0,8	-	-	-	-	-	-	-	-	-	-	-	-	-	-	-	-	-	-	-	-	-	-	-	-	-	-	-	-	-	-	-
SNMG120412MS	12,70	12,70	1,2	-	-	-	-	-	-	-	-	-	-	-	-	-	-	-	-	-	-	-	-	-	-	-	-	-	-	-	-	-	-	-
SNMG150608MS	15,88	15,88	0,8	-	-	-	-	-	-	-	-	-	-	-	-	-	-	-	-	-	-	-	-	-	-	-	-	-	-	-	-	-	-	-
SNMG150612MS	15,88	15,88	1,2	-	-	-	-	-	-	-	-	-	-	-	-	-	-	-	-	-	-	-	-	-	-	-	-	-	-	-	-	-	-	-
SNMG190612MS	19,05	19,05	1,2	-	-	-	-	-	-	-	-	-	-	-	-	-	-	-	-	-	-	-	-	-	-	-	-	-	-	-	-	-	-	-



● 首选  
○ 备选

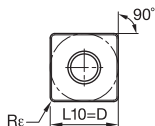
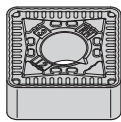

■ SNMG-RN

目录编号	D	L10	Re	KCP05B	KCP05	KCP10B	KCP10	KCP25B	KCP25	KCP30B	KCP30	KCP40B	KCP40	KCK05B	KCK05	KCK15B	KCK15	KCK20B	KCK20	KCM15B	KCM15	KCM25B	KCM25	KCM35B	KCM35	KCPK05	K313	K68	KCU10	KCU25	KC5010	KC5025	KC5410	KT315
SNMG090412RN	9,53	9,53	1,2	-	-	-	●	-	-	-	-	-	-	-	-	-	-	-	-	-	-	-	-	-	-	-	-	-	-	-	-	-	-	-
SNMG120408RN	12,70	12,70	0,8	-	-	-	-	-	-	-	-	-	-	-	-	-	-	-	-	-	-	-	-	-	-	-	-	-	-	-	-	-	-	-
SNMG120412RN	12,70	12,70	1,2	-	-	●	-	●	-	-	-	●	-	-	-	-	-	-	-	-	-	-	-	-	-	-	-	-	-	-	-	-	-	-
SNMG120416RN	12,70	12,70	1,6	-	-	●	-	●	-	-	-	●	-	-	-	-	-	-	-	-	-	-	-	-	-	-	-	-	-	-	-	-	-	-
SNMG150608RN	15,88	15,88	0,8	-	-	-	●	-	-	-	-	-	-	-	-	-	-	-	-	-	-	-	-	-	-	-	-	-	-	-	-	-	-	-
SNMG150612RN	15,88	15,88	1,2	-	-	●	-	●	-	-	-	●	-	-	-	-	-	-	-	-	-	-	-	-	-	-	-	-	-	-	-	-	-	-
SNMG150616RN	15,88	15,88	1,6	-	-	-	●	●	-	-	-	●	-	-	-	-	-	-	-	-	-	-	-	-	-	-	-	-	-	-	-	-	-	-
SNMG190608RN	19,05	19,05	0,8	-	-	-	●	-	-	-	-	-	-	-	-	-	-	-	-	-	-	-	-	-	-	-	-	-	-	-	-	-	-	-
SNMG190612RN	19,05	19,05	1,2	-	-	●	-	●	-	-	-	●	-	-	-	-	-	-	-	-	-	-	-	-	-	-	-	-	-	-	-	-	-	-
SNMG190616RN	19,05	19,05	1,6	-	-	●	-	●	-	-	-	●	-	-	-	-	-	-	-	-	-	-	-	-	-	-	-	-	-	-	-	-	-	-
SNMG190624RN	19,05	19,05	2,4	-	-	-	-	-	●	-	-	-	-	-	-	-	-	-	-	-	-	-	-	-	-	-	-	-	-	-	-	-	-	-
SNMG250924RN	25,40	25,40	2,4	-	-	-	-	-	-	●	-	-	-	-	-	-	-	-	-	-	-	-	-	-	-	-	-	-	-	-	-	-	-	-

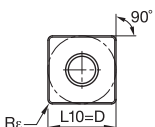
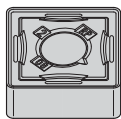

■ SNMG-RP

目录编号	D	L10	Re	KCP05B	KCP05	KCP10B	KCP10	KCP25B	KCP25	KCP30B	KCP30	KCP40B	KCP40	KCK05B	KCK05	KCK15B	KCK15	KCK20B	KCK20	KCM15B	KCM15	KCM25B	KCM25	KCM35B	KCM35	KCPK05	K313	K68	KCU10	KCU25	KC5010	KC5025	KC5410	KT315
SNMG120408RP	12,70	12,70	0,8	-	●	-	●	●	-	-	-	-	-	-	-	-	-	-	-	-	-	-	-	-	-	-	-	-	-	-	-	-	-	-
SNMG120412RP	12,70	12,70	1,2	-	●	-	●	●	-	-	-	-	-	-	-	-	-	-	-	-	-	-	-	-	-	-	-	-	-	-	-	-	-	-
SNMG120416RP	12,70	12,70	1,6	-	-	-	●	-	-	-	-	-	-	-	-	-	-	-	-	-	-	-	-	-	-	-	-	-	-	-	-	-	-	-
SNMG150612RP	15,88	15,88	1,2	-	-	●	-	●	-	-	-	-	-	-	-	-	-	-	-	-	-	-	-	-	-	-	-	-	-	-	-	-	-	-
SNMG150616RP	15,88	15,88	1,6	-	-	●	-	●	-	-	-	-	-	-	-	-	-	-	-	-	●	-	-	-	-	-	-	-	-	-	-	-	-	-
SNMG190612RP	19,05	19,05	1,2	-	-	●	-	●	-	-	-	●	-	-	-	-	-	-	-	-	-	-	-	-	-	-	-	-	-	-	-	-	-	-
SNMG190616RP	19,05	19,05	1,6	-	-	●	-	●	-	-	-	●	-	-	-	-	-	-	-	-	-	●	-	-	-	-	-	-	-	-	-	-	-	-



● 首选  
○ 备选

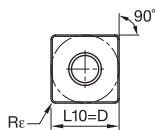
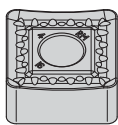

■ SNMM-RM

目录编号	D	L10	Rε	KCP05B	KCP05	KCP10B	KCP10	KCP25B	KCP25	KCP30B	KCP30	KCP40B	KCP40	KCK05B	KCK05	KCK15B	KCK15	KCK20B	KCK20	KCM15B	KCM15	KCM25B	KCM25	KCM35B	KCM35	KCPK05	K313	K68	KCU10	KCU25	KC5010	KC5025	KC5410	KT315
SNMM120408RM	12,70	12,70	0,8	-	-	-	-	-	-	-	-	-	-	-	-	-	-	-	-	-	-	-	-	-	-	-	-	-	-	-	-	-	-	-
SNMM120412RM	12,70	12,70	1,2	-	-	-	-	-	●	-	-	-	-	-	-	-	-	-	-	-	-	-	-	-	-	-	-	-	-	-	-	-	-	-
SNMM150612RM	15,88	15,88	1,2	-	-	-	-	●	●	-	-	-	-	-	-	-	-	-	-	-	-	-	-	-	-	-	-	-	-	-	-	-	-	-
SNMM150616RM	15,88	15,88	1,6	-	-	-	●	●	●	-	-	-	-	-	-	-	-	-	-	-	-	-	-	-	-	-	-	-	-	-	-	-	-	-
SNMM190612RM	19,05	19,05	1,2	-	-	-	●	●	●	-	-	-	-	-	-	-	-	-	-	-	-	-	-	-	-	-	-	-	-	-	-	-	-	-
SNMM190616RM	19,05	19,05	1,6	-	-	-	●	●	●	-	-	-	●	-	-	-	-	-	-	-	-	-	-	-	-	-	-	-	-	-	-	-	-	-
SNMM190624RM	19,05	19,05	2,4	-	-	-	-	●	●	-	-	●	-	-	-	-	-	-	-	-	-	-	-	-	-	-	-	-	-	-	-	-	-	-
SNMM250724RM	25,40	25,40	2,4	-	-	-	●	●	●	-	-	-	-	-	-	-	-	-	-	-	-	-	-	-	-	-	-	-	-	-	-	-	-	-
SNMM250924RM	25,40	25,40	2,4	-	-	-	-	●	●	●	-	●	-	-	-	-	-	-	-	-	-	-	-	-	-	-	-	-	-	-	-	-	-	-

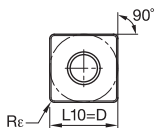
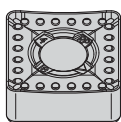

■ SNMM-RP

目录编号	D	L10	Rε	KCP05B	KCP05	KCP10B	KCP10	KCP25B	KCP25	KCP30B	KCP30	KCP40B	KCP40	KCK05B	KCK05	KCK15B	KCK15	KCK20B	KCK20	KCM15B	KCM15	KCM25B	KCM25	KCM35B	KCM35	KCPK05	K313	K68	KCU10	KCU25	KC5010	KC5025	KC5410	KT315
SNMM120408RP	12,70	12,70	0,8	-	-	-	-	-	●	-	-	-	-	-	-	-	-	-	-	-	-	-	-	-	-	-	-	-	-	-	-	-	-	-
SNMM120412RP	12,70	12,70	1,2	-	-	-	-	-	●	-	-	-	-	-	-	-	-	-	-	-	-	-	-	-	-	-	-	-	-	-	-	-	-	-
SNMM150612RP	15,88	15,88	1,2	-	-	-	-	-	●	-	-	-	-	-	-	-	-	-	-	-	-	-	-	-	-	-	-	-	-	-	-	-	-	-
SNMM150616RP	15,88	15,88	1,6	-	-	-	●	-	●	-	-	-	-	-	-	-	-	-	-	-	-	-	-	-	-	-	-	-	-	-	-	-	-	-
SNMM190612RP	19,05	19,05	1,2	-	-	-	-	-	●	-	-	-	-	-	-	-	-	-	-	-	-	-	-	-	-	-	-	-	-	-	-	-	-	-
SNMM190616RP	19,05	19,05	1,6	-	-	-	-	-	●	-	-	-	●	-	-	-	-	-	-	-	-	-	-	-	-	-	-	-	-	-	-	-	-	-
SNMM190624RP	19,05	19,05	2,4	-	-	-	-	●	●	-	-	-	-	-	-	-	-	-	-	-	-	-	-	-	-	-	-	-	-	-	-	-	-	-
SNMM250724RP	25,40	25,40	2,4	-	-	-	-	●	●	-	-	-	●	-	-	-	-	-	-	-	-	-	-	-	-	-	-	-	-	-	-	-	-	-
SNMM250924RP	25,40	25,40	2,4	-	-	-	-	●	●	●	-	-	-	-	-	-	-	-	-	-	-	●	●	-	-	-	-	-	-	-	-	-	-	-

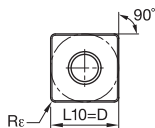
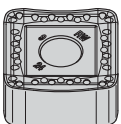

■ SNMM-RW

目录编号	D	L10	Rε	KCP05B	KCP05	KCP10B	KCP10	KCP25B	KCP25	KCP30B	KCP30	KCP40B	KCP40	KCK05B	KCK05	KCK15B	KCK15	KCK20B	KCK20	KCM15B	KCM15	KCM25B	KCM25	KCM35B	KCM35	KCPK05	K313	K68	KCU10	KCU25	KC5010	KC5025	KC5410	KT315
SNMM190624RW	19,05	19,05	2,4	-	-	-	-	●	-	-	-	-	-	-	-	-	-	-	-	-	-	-	-	-	-	-	-	-	-	-	-	-	-	-
SNMM250724RW	25,40	25,40	2,4	-	-	-	-	●	-	-	-	-	-	-	-	-	-	-	-	-	-	-	-	-	-	-	-	-	-	-	-	-	-	-

● 首选  
○ 备选

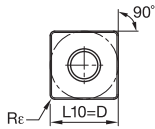
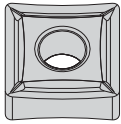

■ SNMP

目录编号	D	L10	Re	KCP05B	KCP05	KCP10B	KCP10	KCP25B	KCP25	KCP30B	KCP30	KCP40B	KCP40	KCK05B	KCK05	KCK15B	KCK15	KCK20B	KCK20	KCM15B	KCM15	KCM25B	KCM25	KCM35B	KCM35	KCPK05	K313	K68	KCU10	KCU25	KC5010	KC5025	KC5410	KT315
SNMP190612	19,05	19,05	1,2	-	-	-	-	-	-	-	-	-	-	-	-	-	-	-	-	-	-	-	-	-	-	-	●	●	-	-	-	-	-	-

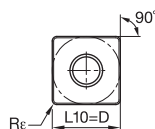
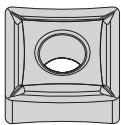

■ SNMP-K

目录编号	D	L10	Re	KCP05B	KCP05	KCP10B	KCP10	KCP25B	KCP25	KCP30B	KCP30	KCP40B	KCP40	KCK05B	KCK05	KCK15B	KCK15	KCK20B	KCK20	KCM15B	KCM15	KCM25B	KCM25	KCM35B	KCM35	KCPK05	K313	K68	KCU10	KCU25	KC5010	KC5025	KC5410	KT315
SNMP120408K	12,70	12,70	0,8	-	-	-	-	-	●	-	-	-	-	-	-	-	-	-	-	-	-	-	-	-	-	-	-	-	-	-	-	-	-	

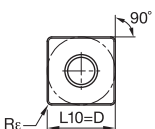
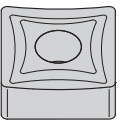

■ SNMS

目录编号	D	L10	Re	KCP05B	KCP05	KCP10B	KCP10	KCP25B	KCP25	KCP30B	KCP30	KCP40B	KCP40	KCK05B	KCK05	KCK15B	KCK15	KCK20B	KCK20	KCM15B	KCM15	KCM25B	KCM25	KCM35B	KCM35	KCPK05	K313	K68	KCU10	KCU25	KC5010	KC5025	KC5410	KT315
SNMS120408	12,70	12,70	0,8	-	-	-	-	-	-	-	-	-	-	-	-	-	-	-	-	-	-	-	-	-	-	-	●	-	-	-	-	-	-	
SNMS190612	19,05	19,05	1,2	-	-	-	-	-	-	-	-	-	-	-	-	-	-	-	-	-	-	-	-	-	-	-	●	-	-	-	-	-	-	

P	●	●	●	●	●	●	●	●	●	●	●	●	●	○	○	○	○	○	○	○	○	○	○	○	○	○	○	○	○	○	○	○	○	○	○
M	●	●	●	●	●	●	●	●	●	●	●	●	●	○	○	○	○	○	○	○	○	○	○	○	○	○	○	○	○	○	○	○	○	○	○
K	○	○	○	○	○	○	○	○	○	○	○	○	○	○	○	○	○	○	○	○	○	○	○	○	○	○	○	○	○	○	○	○	○	○	○
N	○	○	○	○	○	○	○	○	○	○	○	○	○	○	○	○	○	○	○	○	○	○	○	○	○	○	○	○	○	○	○	○	○	○	○
S	○	○	○	○	○	○	○	○	○	○	○	○	○	○	○	○	○	○	○	○	○	○	○	○	○	○	○	○	○	○	○	○	○	○	○
H	○	○	○	○	○	○	○	○	○	○	○	○	○	○	○	○	○	○	○	○	○	○	○	○	○	○	○	○	○	○	○	○	○	○	○



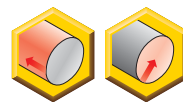
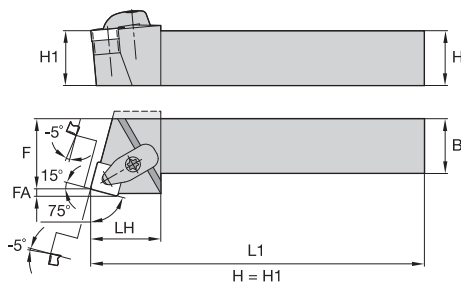
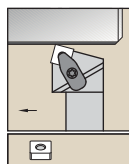

**DSBN-KC 75°**

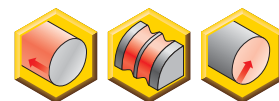
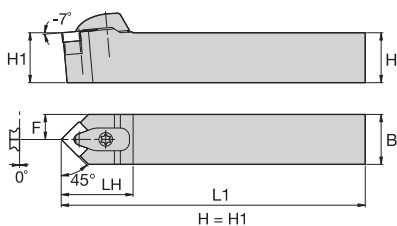
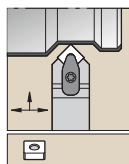
订货号	目录编号	H	B	F	L1	LH	FA	刀片	垫片	垫片螺钉	Torx Plus	夹具装配件	Torx Plus	槽销	可选择锁定销
左手															
1875215	DSBNL2525M12KC04	25	25	22,0	150	32,0	3,0	SN..120408	ISSN443	KMSP415IP	15 IP	CM234R ASSY	15 IP	SSP025016M	KLM46L15IP

**DSDN-KC 45°**

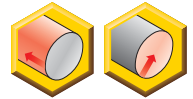
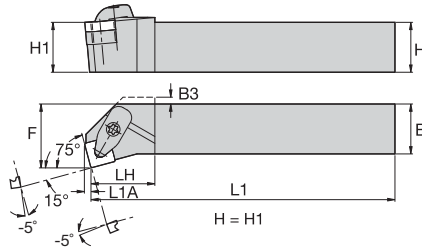
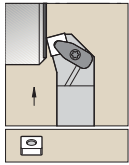

订货号	目录编号	H	B	F	L1	LH	刀片	垫片	垫片螺钉	Torx Plus	夹具装配件	Torx Plus	槽销	可选择锁定销
1875210	DSDNN2020K12KC04	20	20	10,0	125	36,0	SN..120408	ISSN433	KMSP415IP	15 IP	CM234R ASSY	15 IP	SSP025016M	KLM4615IP
1875211	DSDNN2525M12KC04	25	25	12,0	150	36,0	SN..120408	ISSN443	KMSP415IP	15 IP	CM234R ASSY	15 IP	SSP025016M	KLM46L15IP
1875216	DSDNN2525M15KC06	25	25	12,0	150	42,0	SN..150612	ISSN543	KMSP515IP	15 IP	CM209R ASSY	15 IP	SSP025016M	KLM58L15IP
2273139	DSDNN3232P19KC06	32	32	15,5	170	44,0	SN..190612	ISSN643	KMSP625IP	25 IP	CM210R ASSY	25 IP	SSP025016M	KLM68L25IP
2456320	DSDNN4040S25KC09	40	40	19,5	250	59,0	SN..250924	ISSN846	KMSP825IP	25 IP	CM236R ASSY	25 IP	SSP025018M	KLM81025IP



■ DSKN-KC 75°

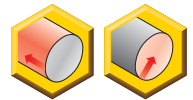
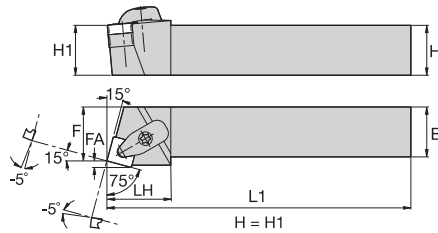
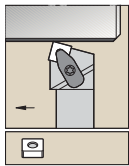

订货号	目录编号	H	B	F	L1	LH	L1A	B3	刀片	垫片	垫片螺钉	Torx Plus	夹具装配件	Torx Plus	槽销	可选择锁定销
右手																
1875219	DSKNR2525M12KC04	25	25	32,0	150	32,0	3,1	4,0	SN..120408	ISSN443	KMSP415IP	15 IP	CM234R ASSY	15 IP	SSP025016M	KLM46L15IP
左手																
1875220	DSKNL2525M12KC04	25	25	32,0	150	32,0	3,1	4,0	SN..120408	ISSN443	KMSP415IP	15 IP	CM234R ASSY	15 IP	SSP025016M	KLM46L15IP



■ DSRN-KC 75°



订货号	目录编号	H	B	F	L1	LH	FA	刀片	垫片	垫片螺钉	Torx Plus	夹具装配件	Torx Plus	槽销	可选择锁定销
右手															
1875228	DSRNR2525M12KC04	25	25	27,0	150	32,0	3,3	SN..120408	ISSN443	KMSP415IP	15 IP	CM234R ASSY	15 IP	SSP025016M	KLM46L15IP
2456321	DSRNR4040S25KC09	40	40	43,0	250	52,0	6,1	SN..250924	ISSN846	KMSP825IP	25 IP	CM236R ASSY	25 IP	SSP025018M	KLM81025IP
左手															
2456322	DSRNL4040S25KC09	40	40	43,0	250	52,0	6,1	SN..250924	ISSN846	KMSP825IP	25 IP	CM236R ASSY	25 IP	SSP025018M	KLM81025IP

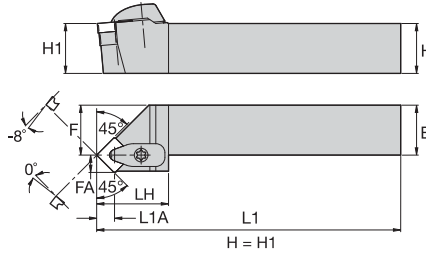
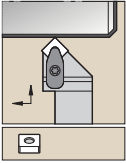

ISO 车削刀具

■ DSSN-KC 45°



订货号	目录编号	H	B	F	L1	LH	FA	L1A	刀片	垫片	垫片螺钉	Torx Plus 夹具装配件	Torx Plus 槽销	可选择锁定销
右手														
1875202	DSSNR2020K12KC04	20	20	25,0	125	36,0	8,4	8,7	SN..120408	ISSN433	KMSP415IP	15 IP CM234R ASSY	15 IP SSP025016M	KLM4615IP
1875195	DSSNR2525M12KC04	25	25	32,0	150	36,0	8,4	9,6	SN..120408	ISSN443	KMSP415IP	15 IP CM234R ASSY	15 IP SSP025016M	KLM46L15IP
2273156	DSSNR3225P12KC04	32	25	32,0	170	35,4	8,4	8,7	SN..120408	ISSN443	KMSP415IP	15 IP CM234R ASSY	15 IP SSP025016M	KLM46L15IP
左手														
1875203	DSSNL2525M12KC04	25	25	32,0	150	36,0	8,4	8,7	SN..120408	ISSN443	KMSP415IP	15 IP CM234R ASSY	15 IP SSP025016M	KLM46L15IP

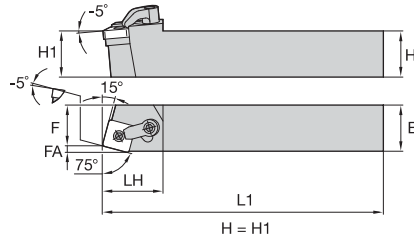
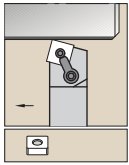

■ MSBN 75°



订货号	目录编号	H	B	F	L1	LH	FA	刀片	垫片	锁销	六角	夹具	夹紧螺钉	六角	
右手															
1101893	MSBNR3232P19	32	32	27,0	170	40,0	4,6	SN..190612	ISSN633	KLM68	4 mm	CKM12	STCM4	4 mm	
1101954	MSBNR4040R19	40	40	35,0	200	40,0	4,6	SN..190612	ISSN633	KLM68	4 mm	CKM12	STCM4	4 mm	
1100937	MSBNR2020K12	61	20	17,0	125	32,0	3,1	SN..120408	ISSN433	KLM46	2.5 mm	CKM21	STCM20	3 mm	
1101359	MSBNR2525M15	80	25	22,0	150	35,0	3,8	SN..150612	ISSN533	KLM58	3 mm	CKM21	STCM20	3 mm	
1100941	MSBNR2525M12	86	25	22,0	150	32,0	3,1	SN..120408	ISSN433	KLM46	2.5 mm	CKM21	STCM20	3 mm	
1101361	MSBNR3232P15	100	32	27,0	170	35,0	3,8	SN..150612	ISSN533	KLM58	3 mm	CKM21	STCM20	3 mm	
1101289	MSBNR3225P12	106	32	22,0	170	32,0	3,1	SN..120408	ISSN433	KLM46	2.5 mm	CKM21	STCM20	3 mm	
左手															
1102640	MSBNL3232P19	32	32	27,0	170	40,0	4,6	SN..190612	ISSN633	KLM68	4 mm	CKM12	STCM4	4 mm	
1099148	MSBNL4040R19	40	40	35,0	200	40,0	4,6	SN..190612	ISSN633	KLM68	4 mm	CKM12	STCM4	4 mm	
1102242	MSBNL2020K12	61	20	17,0	125	32,0	3,1	SN..120408	ISSN433	KLM46	2.5 mm	CKM21	STCM20	3 mm	
1102318	MSBNL2525M15	80	25	22,0	150	35,0	3,8	SN..150612	ISSN533	KLM58	3 mm	CKM21	STCM20	3 mm	
1102243	MSBNL2525M12	86	25	22,0	150	32,0	3,1	SN..120408	ISSN433	KLM46	2.5 mm	CKM21	STCM20	3 mm	
1102319	MSBNL3232P15	100	32	27,0	170	35,0	3,8	SN..150612	ISSN533	KLM58	3 mm	CKM21	STCM20	3 mm	
1102314	MSBNL3225P12	106	32	22,0	170	32,0	3,1	SN..120408	ISSN433	KLM46	2.5 mm	CKM21	STCM20	3 mm	

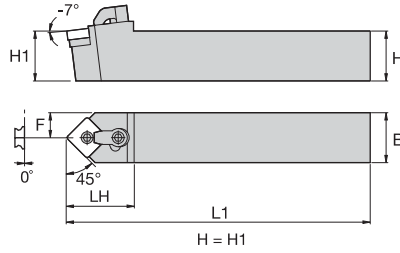
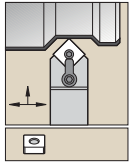

■ MSDN 45°



订货号	目录编号	H	B	F	L1	LH	刀片	垫片	锁销	六角	夹具	夹紧螺钉	六角
1101891	MSDNN2525M12	25	25	12,0	150	32,0	SN..120408	ISSN432	KLM46	2.5 mm	CKM21	STCM20	3 mm
1101889	MSDNN1616H09	44	16	8,0	100	28,0	SN..090308	ISSN332	KLM34L	2 mm	CKM19	STCM9	2.5 mm
1101890	MSDNN2020K12	61	20	10,0	125	32,0	SN..120408	ISSN432	KLM46	2.5 mm	CKM21	STCM20	3 mm
1101892	MSDNN2525M15	80	25	12,5	150	35,0	SN..150612	ISSN533	KLM58	3 mm	CKM21	STCM20	3 mm
1101888	MSDNN3232P19	86	32	16,0	170	42,0	SN..190612	ISSN633	KLM68	4 mm	CKM12	STCM4	4 mm
1101713	MSDNN3225P12	106	32	12,5	170	32,0	SN..120408	ISSN432	KLM46	2.5 mm	CKM21	STCM20	3 mm

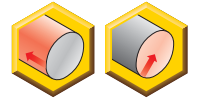
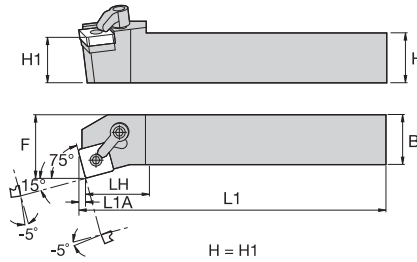
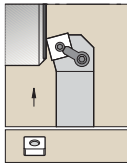

■ MSKN 75°



订货号	目录编号	H	B	F	L1	LH	L1A	刀片	垫片	锁销	六角	夹具	夹紧螺钉	六角
右手														
1101886	MSKNR2525M12	25	25	32,0	150	32,0	3,1	SN..120408	ISSN432	KLM46	2.5 mm	CKM21	STCM20	3 mm
1101957	MSKNR3232P19	32	32	40,0	170	40,0	4,6	SN..190612	ISSN633	KLM68	4 mm	CKM12	STCM4	4 mm
左手														
1102637	MSKNL2525M12	25	25	32,0	150	32,0	3,1	SN..120408	ISSN432	KLM46	2.5 mm	CKM21	STCM20	3 mm
1102638	MSKNL3225P12	32	25	32,0	170	32,0	3,1	SN..120408	ISSN432	KLM46	2.5 mm	CKM21	STCM20	3 mm
1099158	MSKNL3232P15	32	32	40,0	170	35,0	3,7	SN..150612	ISSN533	KLM58	3 mm	CKM21	STCM20	3 mm
1102641	MSKNL3232P19	32	32	40,0	170	40,0	4,6	SN..190612	ISSN633	KLM68	4 mm	CKM12	STCM4	4 mm

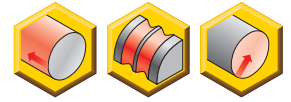
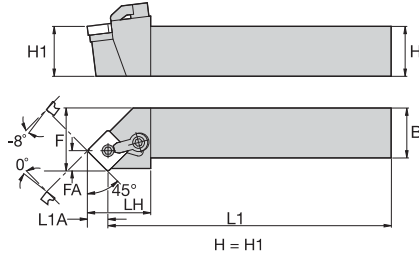
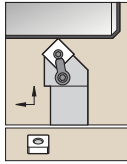

■ MSSN 45°



订货号	目录编号	H	B	F	L1	LH	FA	L1A	刀片	垫片	锁销	六角	夹具	夹紧螺钉	六角
右手															
1102166	MSSNR3232P19	32	32	40,0	170	40,0	12,5	12,5	SN..190612	ISSN633	KLM68	4 mm	CKM12	STCM4	4 mm
1102164	MSSNR2020K12	71	20	25,0	125	32,0	8,4	9,6	SN..120408	ISSN433	KLM46	2.5 mm	CKM21	STCM20	3 mm
1102165	MSSNR2525M12	96	25	32,0	150	32,0	8,4	9,6	SN..120408	ISSN433	KLM46	2.5 mm	CKM21	STCM20	3 mm
左手															
1102717	MSSNL2020K12	20	20	25,0	125	32,0	8,4	8,3	SN..120408	ISSN433	KLM46	2.5 mm	CKM21	STCM20	3 mm
1102719	MSSNL3232P19	32	32	40,0	170	40,0	12,5	12,5	SN..190612	ISSN633	KLM68	4 mm	CKM12	STCM4	4 mm
1102718	MSSNL2525M12	96	25	32,0	150	32,0	8,4	9,6	SN..120408	ISSN433	KLM46	2.5 mm	CKM21	STCM20	3 mm

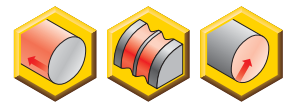
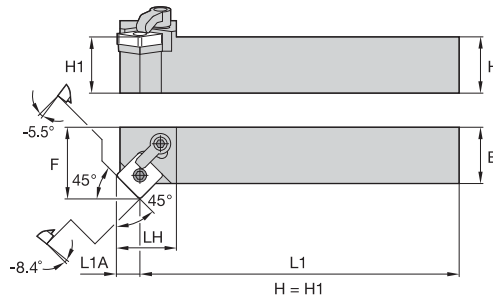
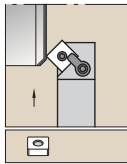

■ MSZN 45°

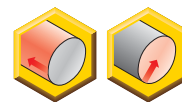
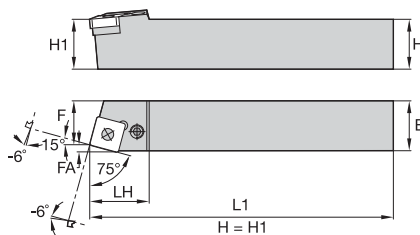
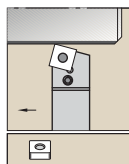

订货号	目录编号	H	B	F	L1	LH	L1A	刀片	垫片	锁销	六角	夹具	夹紧螺钉	六角	
右手															
1101884	MSZNR2525M12	25	25	32,0	150	25,0	8,5	SN..120408	ISSN432	KLM46	2.5 mm	CKM21	STCM20	3 mm	
左手															
1102634	MSZNL2525M12	25	25	32,0	150	25,0	8,5	SN..120408	ISSN432	KLM46	2.5 mm	CKM21	STCM20	3 mm	

**PSBN 75°**

订货号	目录编号	H	B	F	L1	LH	FA	刀片	垫片	垫片销	冲头	杠杆	杠杆螺钉	Torx Plus	
<b>右手</b>															
1244833	PSBNR2020K12	20	20	17,0	125	26,0	3,1	SN..120408	512.063	513.023	515.018	511.023	514.123	15 IP	
1244677	PSBNR2525M12	25	25	22,0	150	26,0	3,1	SN..120408	512.063	513.023	515.018	511.023	514.123	15 IP	
1244834	PSBNR2525M15	25	25	22,0	150	36,0	3,8	SN..150608	512.025	513.025	515.022	511.025	514.125	15 IP	
1244678	PSBNR3225P12	32	25	22,0	170	26,0	3,1	SN..120408	512.063	513.023	515.018	511.023	514.123	15 IP	
1244680	PSBNR3232P15	32	32	27,0	170	33,0	3,8	SN..150608	512.025	513.025	515.022	511.025	514.125	15 IP	
1244681	PSBNR3232P19	32	32	27,0	170	40,0	4,6	SN..190612	512.083	513.033	515.022	511.033	514.133	25 IP	
1244682	PSBNR4040S19	40	40	35,0	250	38,0	4,6	SN..190612	512.083	513.033	515.022	511.033	514.133	25 IP	
1244683	PSBNR4040S25	40	40	35,0	250	47,0	5,9	SN..250724	512.092	513.038	515.028	511.038	514.138	30 IP	
<b>左手</b>															
1244774	PSBNL2020K12	20	20	17,0	125	26,0	3,1	SN..120408	512.063	513.023	515.018	511.023	514.123	15 IP	
1244668	PSBNL2525M12	25	25	22,0	150	26,0	3,1	SN..120408	512.063	513.023	515.018	511.023	514.123	15 IP	
1244669	PSBNL2525M15	25	25	22,0	150	36,0	3,8	SN..150608	512.025	513.025	515.022	511.025	514.125	15 IP	
1244672	PSBNL3232P15	32	32	27,0	170	33,0	3,8	SN..150608	512.025	513.025	515.022	511.025	514.125	15 IP	
1244673	PSBNL3232P19	32	32	27,0	170	40,0	4,6	SN..190612	512.083	513.033	515.022	511.033	514.133	25 IP	
1244674	PSBNL4040S19	40	40	35,0	250	38,0	4,6	SN..190612	512.083	513.033	515.022	511.033	514.133	25 IP	
1244675	PSBNL4040S25	40	40	35,0	250	47,0	5,9	SN..250724	512.092	513.038	515.028	511.038	514.138	30 IP	

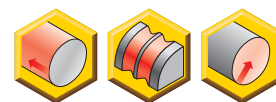
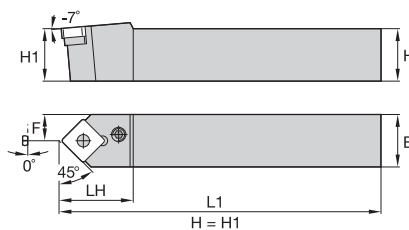
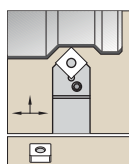
**PSDN 45°**

订货号	目录编号	H	B	F	L1	LH	刀片	垫片	垫片销	冲头	杠杆	杠杆螺钉	Torx Plus
1244686	PSDNN1616H09	16	16	8,0	100	22,0	SN..090308	512.053	513.019	515.018	511.018	514.118	10 IP
1244863	PSDNN2020K12	20	20	10,0	125	26,0	SN..120408	512.063	513.023	515.018	511.023	514.123	15 IP
1156970	PSDNN2525M12	25	25	12,5	150	26,0	SN..120408	512.063	513.023	515.018	511.023	514.123	15 IP
1244687	PSDNN3225P12	32	25	12,5	170	28,0	SN..120408	512.063	513.023	515.018	511.023	514.123	15 IP
1244688	PSDNN3225P19	32	25	12,5	170	40,0	SN..190612	512.083	513.033	515.022	511.033	514.133	25 IP
1244835	PSDNN3232P19	32	32	16,0	170	40,0	SN..190612	512.083	513.033	515.022	511.033	514.133	25 IP
1147356	PSDNN4040S25	40	40	20,0	250	50,0	SN..250724	512.092	513.038	515.028	511.038	514.138	30 IP

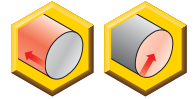
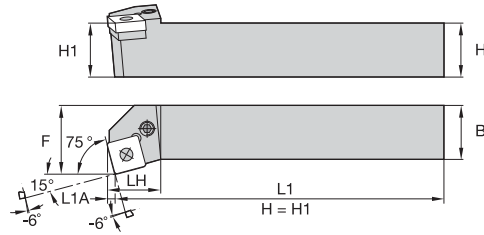
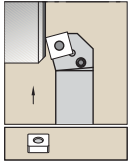

■ PSKN 75°



订货号	目录编号	H	B	F	L1	LH	L1A	刀片	垫片	垫片销	冲头	杠杆	杠杆螺钉	Torx Plus
右手														
1244699	PSKNR2020K12	20	20	25,0	125	23,0	3,1	SN..120408	512.063	513.023	515.018	511.023	514.123	15 IP
1244836	PSKNR2525M12	25	25	32,0	150	23,0	3,1	SN..120408	512.063	513.023	515.018	511.023	514.123	15 IP
1244701	PSKNR3232P15	32	32	40,0	170	32,0	3,8	SN..150608	512.025	513.025	515.022	511.025	514.125	15 IP
1244702	PSKNR3232P19	32	32	40,0	170	37,5	4,6	SN..190612	512.083	513.033	515.022	511.033	514.133	25 IP
左手														
1244690	PSKNL2525M12	25	25	32,0	150	23,0	3,1	SN..120408	512.063	513.023	515.018	511.023	514.123	15 IP
1244693	PSKNL3232P19	32	32	40,0	170	37,5	4,6	SN..190612	512.083	513.033	515.022	511.033	514.133	25 IP



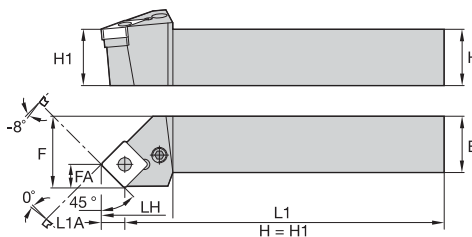
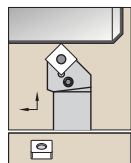

ISO 车削刀具

**■ PSSN 45°**

订货号	目录编号	H	B	F	L1	LH	FA	L1A	刀片	垫片	垫片销	冲头	杠杆	杠杆螺钉	Torx Plus
右手															
1244718	PSSNR2020K09	20	20	25,0	125	26,0	6,1	6,1	SN..090308	512.053	513.019	515.018	511.018	514.118	10 IP
1244837	PSSNR2020K12	20	20	25,0	125	28,0	8,3	8,3	SN..120408	512.063	513.023	515.018	511.023	514.123	15 IP
1156961	PSSNR2525M12	25	25	32,0	150	28,0	8,3	8,3	SN..120408	512.063	513.023	515.018	511.023	514.123	15 IP
1244719	PSSNR2525M15	25	25	32,0	150	32,0	10,2	10,2	SN..150608	512.025	513.025	515.022	511.025	514.125	15 IP
1244720	PSSNR3225P12	32	25	32,0	170	29,0	8,3	8,3	SN..120408	512.063	513.023	515.018	511.023	514.123	15 IP
1244722	PSSNR3232P15	32	32	40,0	170	32,0	10,0	11,5	SN..150612	512.025	513.025	515.022	511.025	514.125	15 IP
1244838	PSSNR3232P19	32	32	40,0	170	37,5	12,5	12,5	SN..190612	512.083	513.033	515.022	511.033	514.133	25 IP
1244723	PSSNR4040S19	40	40	50,0	250	37,5	12,5	12,5	SN..190612	512.083	513.033	515.022	511.033	514.133	25 IP
左手															
1244709	PSSNL2020K12	20	20	25,0	125	28,0	8,3	8,3	SN..120408	512.063	513.023	515.018	511.023	514.123	15 IP
1244789	PSSNL2525M12	25	25	32,0	150	28,0	8,3	8,3	SN..120408	512.063	513.023	515.018	511.023	514.123	15 IP
1244710	PSSNL2525M15	25	25	32,0	150	32,0	10,2	10,2	SN..150608	512.025	513.025	515.022	511.025	514.125	15 IP
1244711	PSSNL3225P12	32	25	32,0	170	29,0	8,3	8,3	SN..120408	512.063	513.023	515.018	511.023	514.123	15 IP
1244714	PSSNL3232P19	32	32	40,0	170	37,5	12,5	12,5	SN..190612	512.083	513.033	515.022	511.033	514.133	25 IP
1244715	PSSNL4040S19	40	40	50,0	250	37,5	12,5	12,5	SN..190612	512.083	513.033	515.022	511.033	514.133	25 IP



带有内冷的钢刀柄。

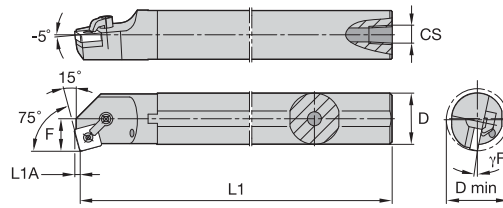

■ A-MSKN 75°



订货号	目录编号	D	D min	F	L1	L1A	CS	γF°	刀片	垫片	锁销	六角	夹具	夹紧螺钉	六角
右手															
1098116	A40TMSKNR12	40	50,0	27,0	300	3,1	1/4-18 NPT	-10.0	SN..120408	ISSN432	KLM46	2.5 mm	CKM21	STCM20	3 mm
1098120	A50UMSKNR19	50	63,0	35,0	350	4,6	1/4-18 NPT	-12.0	SN..190608	ISSN633	KLM68	4 mm	CKM12	STCM4	4 mm
左手															
1098115	A32SMSKNL12	32	40,0	22,0	250	3,1	1/4-18 NPT	-14.0	SN..120408	ISSN432	KLM46	2.5 mm	CKM21	STCM20	3 mm
1098117	A40TMSKNL12	40	50,0	27,0	300	3,1	1/4-18 NPT	-10.0	SN..120408	ISSN432	KLM46	2.5 mm	CKM21	STCM20	3 mm

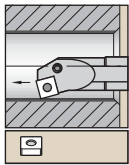

带内冷功能的钢质刀柄。

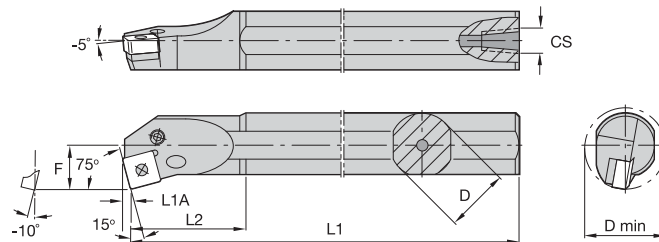

■ A-PSKN 75°



订货号	目录编号	D	D min	F	L1	L2	L1A	CS	刀片	垫片	垫片销	销	杠杆	杠杆螺钉	Torx Plus
右手															
2447480	A25TPSKNR12	25	30,0	17,0	300	43	3,0	1/4-18 NPT	SN..120408	-	-	-	511.022	514.122	10 IP
2447482	A32UPSKNR12	32	40,0	22,0	350	52	3,0	1/4-18 NPT	SN..120408	512.063	513.023	515.018	511.023	514.124	15 IP

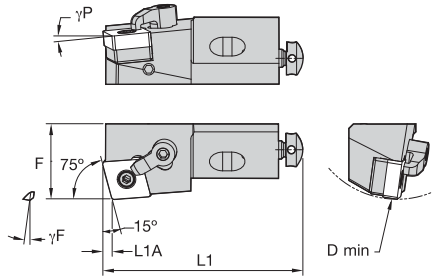

**MSKN 75°**

订货号	目录编号	D min	F	L1	L1A	$\gamma^F$	$\gamma^P$	刀片
右手								
2114011	MSKNR10CA09	40	14,0	50	2,2	-9,0	-5,0	SN..090308/SN..322
2114013	MSKNR12CA12	50	20,0	55	3,0	-9,0	-5,0	SN..120408/SN..432
2074430	MSKNR16CA12	60	25,0	63	3,0	-9,0	-5,0	SN..120408/SN..432
2072222	MSKNR20CA15	70	25,0	70	3,7	-9,0	-5,0	SN..150612/SN..543
2987166	MSKNR25CA19	100	32,0	100	4,6	-9,0	-5,0	SN..190612/SN..543
左手								
3346242	MSKNL12CA12	50	20,0	55	3,0	-9,0	-5,0	SN..120408/SN..432
3330202	MSKNL20CA15	70	25,0	70	3,7	-9,0	-5,0	SN..150612/SN..543

注: 根据 D 最小值和已选刀片尺寸选择配件产品。

**配件**

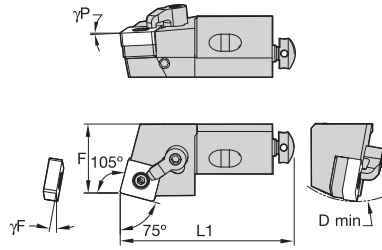
D min	垫片	锁销	六角	夹具	夹紧螺钉	六角	径向调节螺钉	六角	轴向调整螺钉	安装螺钉	安装螺钉	安装螺钉	六角	垫片
40	—	KLM33	2 mm	CKM36	STCM38	2 mm	KUAM28	2 mm	KUAM30	191.405	—	—	4 mm	CSWM 060 050
50	—	KLM43	2 mm	CKM34	STCM38	2 mm	KUAM22	2 mm	KUAM31	—	191.406	—	4 mm	CSWM 060 050
60	ISSN432	KLM46S	2.5 mm	CKM34	STCM9	2.5 mm	KUAM25	2.5 mm	KUAM32	—	191.407	—	5 mm	CSWM 080 050
70	SKSN566K	KLM54	2.5 mm	CKM37	STCM40	2.5 mm	KUAM25	2.5 mm	KUAM32	—	191.407	—	5 mm	CSWM 080 050
100	ISSN633	KLM68	4 mm	CKM35	STCM8	4 mm	KUAM27	4 mm	KUAM32	—	—	MS364	8 mm	CSWM 100 080



■ MSRN 75°

订货号	目录编号	D min	F	L1	γF°	γP°	刀片
<b>右手</b>							
1098436	MSRNR10CA09	40	14,0	50	-9.0	-5.0	SN..090308/SN..322
2078231	MSRNR12CA12	50	20,0	55	-9.0	-5.0	SN..120408/SN..432
2074432	MSRNR16CA12	60	25,0	63	-9.0	-5.0	SN..120408/SN..432
<b>左手</b>							
1282803	MSRNL12CA12	50	20,0	55	-9.0	-5.0	SN..120408/SN..432
3330279	MSRNL16CA12	60	25,0	63	-9.0	-5.0	SN..120408/SN..432
3330203	MSRNL20CA15	70	25,0	70	-9.0	-5.0	SN..150612/SN..543

■ 配件

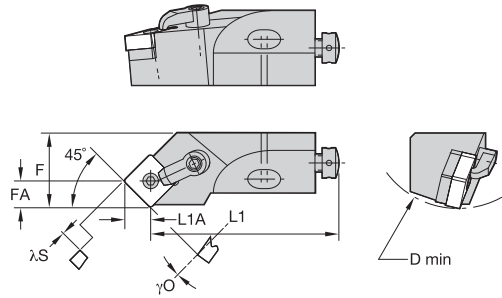
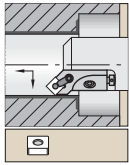

D min	垫片	锁销	六角	夹具	夹紧螺钉	六角	径向调节螺钉	六角	轴向调整螺钉	安装螺钉	安装螺钉	六角	垫片
40	—	KLM33	2 mm	CKM36	STCM38	2 mm	KUAM28	2 mm	KUAM30	191.405	—	4 mm	CSWM 060 050
50	—	KLM43	2 mm	CKM34	STCM38	2 mm	KUAM22	2 mm	KUAM31	—	191.406	4 mm	CSWM 060 050
60	ISSN432	KLM46S	2.5 mm	CKM34	STCM9	2.5 mm	KUAM25	2.5 mm	KUAM32	—	191.407	5 mm	CSWM 080 050
70	SKSN566K	KLM54	2.5 mm	CKM37	STCM40	2.5 mm	KUAM25	2.5 mm	KUAM32	—	191.407	5 mm	CSWM 080 050

**■ MASN 45°**

订货号	目录编号	D min	F	L1	L1A	λS°	γO°	刀片
<b>右手</b>								
1339367	MSSNR10CA09	40	14,0	44	6,1	-13.0	0.0	SN..090308/SN..322
1282807	MSSNR12CA12	50	20,0	47	8,3	-13.0	0.0	SN..120408/SN..432
3330281	MSSNR16CA12	60	25,0	53	8,3	-13.0	0.0	SN..120408/SN..432
3330206	MSSNR20CA15	70	25,0	60	10,3	-13.0	0.0	SN..150612/SN..543
<b>左手</b>								
2071758	MSSNL10CA09	40	14,0	44	6,1	-13.0	0.0	SN..090308/SN..322
2071739	MSSNL12CA12	50	20,0	47	8,3	-13.0	0.0	SN..120408/SN..432

**■ 配件**

D min	垫片	锁销	六角	夹具	夹紧螺钉	六角	径向调节螺钉	六角	轴向调整螺钉	安装螺钉	安装螺钉	六角	垫片
40	—	KLM33	2 mm	CKM36	STCM38	2 mm	KUAM28	2 mm	KUAM30	191.405	—	4 mm	CSWM 060 050
50	—	KLM43	2 mm	CKM34	STCM38	2 mm	KUAM22	2 mm	KUAM31	—	191.406	4 mm	CSWM 060 050
60	ISSN432	KLM46S	2.5 mm	CKM36	STCM9	2.5 mm	KUAM25	2.5 mm	KUAM32	—	191.407	5 mm	CSWM 080 050
70	SKSN566K	KLM54	2.5 mm	CKM37	STCM40	2.5 mm	KUAM25	2.5 mm	KUAM32	—	191.407	5 mm	CSWM 080 050

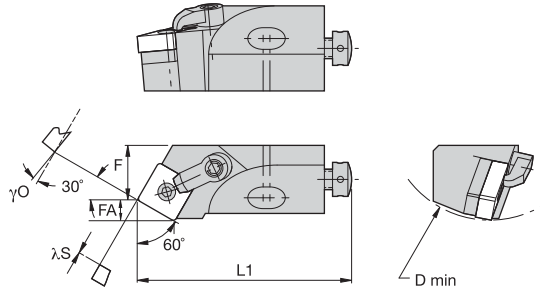

■ MSTN 60°

订货号	目录编号	D min	F	L1	FA	λS°	γ0°	刀片
右手								
3331149	MSTNR10CA09	40,0	9,0	50	13,3	-11.0	0.0	SN..090308/SN..322
2074904	MSTNR12CA12	50,0	13,0	55	5,9	-11.0	0.0	SN..120408/SN..432

■ 配件



D min	锁销	六角	夹具	夹紧螺钉	六角	径向调节螺钉	六角	轴向调整螺钉	安装螺钉	安装螺钉	六角	垫片
40	KLM33	2 mm	CKM36	STCM38	2 mm	KUAM28	2 mm	KUAM30	191.405	—	4 mm	CSWM 060 050
50	KLM43	2 mm	CKM34	STCM38	2 mm	KUAM22	2 mm	KUAM31	—	191.406	4 mm	CSWM 060 050

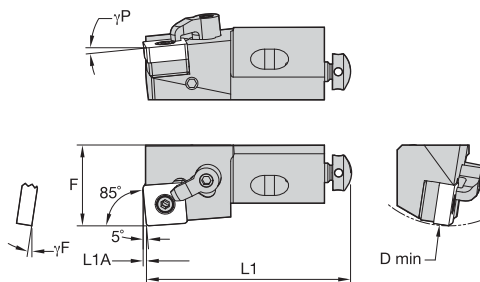
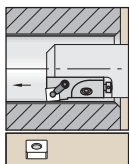

### ■ MSYN 85°

订货号	目录编号	D min	F	L1	L1A	γF°	γP°	刀片
<b>右手</b>								
2114015	MSYNR10CA09	40	14,0	50	0,8	-9,0	-5,0	SN..090308/SN..322
3346274	MSYNR12CA12	50	20,0	55	1,0	-9,0	-5,0	SN..120408/SN..432
3330283	MSYNR16CA12	60	25,0	63	1,0	-9,0	-5,0	SN..120408/SN..432
1098465	MSYNR25CA19	100	32,0	100	1,5	-9,0	-5,0	SN..190612/SN..643
<b>左手</b>								
3331150	MSYNL10CA09	40	14,0	50	0,8	-9,0	-5,0	SN..090308/SN..322
3346273	MSYNL12CA12	50	20,0	55	1,0	-9,0	-5,0	SN..120408/SN..432
1098691	MSYNL20CA15	70	25,0	70	1,3	-9,0	-5,0	SN..150612/SN..543

注: 根据 D 最小值和已选刀片尺寸选择配件产品。

### ■ 配件



D min	垫片	锁销	六角	夹具	夹紧螺钉	六角	径向调节螺钉	六角	轴向调整螺钉	安装螺钉	安装螺钉	安装螺钉	六角	垫片
40	—	KLM33	2 mm	CKM36	STCM38	2 mm	KUAM28	2 mm	KUAM30	191.405	—	—	4 mm	CSWM 060 050
50	—	KLM43	2 mm	CKM34	STCM38	2 mm	KUAM22	2 mm	KUAM31	—	191.406	—	4 mm	CSWM 060 050
60	ISSN432	KLM46S	2.5 mm	CKM36	STCM9	2.5 mm	KUAM25	2.5 mm	KUAM32	—	191.407	—	5 mm	CSWM 080 050
70	SKSN566K	KLM54	2.5 mm	CKM37	STCM40	2.5 mm	KUAM25	2.5 mm	KUAM33	—	191.407	—	6 mm	CSWM 080 050
100	ISSN633	KLM68	4 mm	CKM34	STCM8	4 mm	KUAM27	4 mm	KUAM33	—	—	MS364	8 mm	CSWM 100 080

ISO 车削刀具

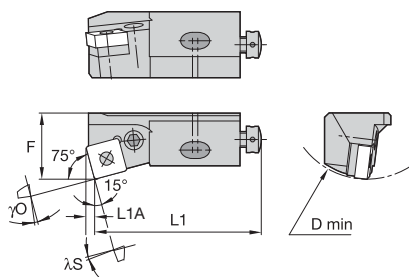
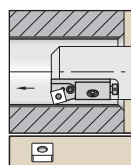

■ PSKN 75°

订货号	目录编号	D min	F	L1	L1A	λS°	γ0°	刀片
右手 1188639	PSKNR12CA-12	50	20,0	55	3,1	-8.0	-6.0	SN..120408/SN..432

■ 配件



D min	杠杆	杠杆螺钉	扳手尺寸调整 杆螺钉	径向调节螺钉	六角	轴向调整螺钉	安装螺钉	六角	垫片
50	511.022	514.122	10 IP	KUAM28	2 mm	KUAM31	191.406	4 mm	CSWM 060 050



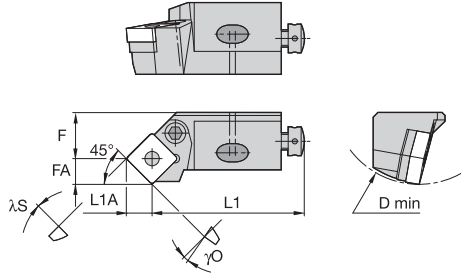

### ■ PSSN 45°

订货号	目录编号	D min	F	L1	FA	L1A	λS°	γO°	γP°	刀片
右手										
1244455	PSSNR12CA-12	50,0	20,0	47	8,7	8,3	-10.0	0.0	—	SN..120408/SN..432
左手										
1244452	PSSNL12CA12	50,0	11,3	47	8,7	8,3	0.0	0.0	-10.0 deg	SN..120408/SN..432

### ■ 配件



D min	杠杆	杠杆螺钉	扳手尺寸调整 杆螺钉	径向调节螺钉	六角	轴向调整螺钉	安装螺钉	六角	垫片
50	511.022	514.122	10 IP	KUAM28	2 mm	KUAM31	191.406	4 mm	CSWM 060 050









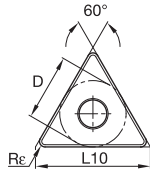
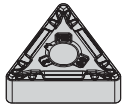

■ TNMG-MR

目录编号	D	L10	Rε	KCP05B	KCP05	KCP10B	KCP10	KCP25B	KCP25	KCP30B	KCP30	KCP40B	KCP40	KCK05B	KCK05	KCK15B	KCK15	KCK20B	KCK20	KCM15B	KCM15	KCM25B	KCM25	KCM35B	KCM35	KCPK05	K313	K68	KCU10	KCU25	KC5010	KC5025	KC5410	KT315
TNMG160408MR	9,53	16,50	0,8	-	-	●	-	●	-	-	-	-	-	-	-	-	-	-	-	-	-	●	●	-	-	-	-	-	-	-	-	-	-	-
TNMG160412MR	9,53	16,50	1,2	-	-	●	-	●	-	-	-	-	-	-	-	●	-	-	-	-	-	-	-	-	-	-	-	-	-	-	-	-	-	-
TNMG220408MR	12,70	22,00	0,8	-	-	-	-	●	-	-	-	-	-	-	-	-	-	-	-	-	-	-	●	-	-	-	-	-	-	-	-	-	-	-
TNMG220412MR	12,70	22,00	1,2	-	-	-	-	●	-	-	-	-	-	-	-	-	-	-	-	-	-	●	-	-	-	-	-	-	-	-	-	-	-	-
TNMG270612MR	15,88	27,50	1,2	-	-	-	-	●	-	-	-	-	-	-	-	-	-	-	-	-	-	-	-	-	-	-	-	-	-	-	-	-	-	-

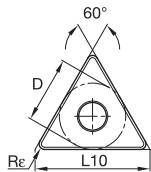

■ TNMG-MG

目录编号	D	L10	Rε	KCP05B	KCP05	KCP10B	KCP10	KCP25B	KCP25	KCP30B	KCP30	KCP40B	KCP40	KCK05B	KCK05	KCK15B	KCK15	KCK20B	KCK20	KCM15B	KCM15	KCM25B	KCM25	KCM35B	KCM35	KCPK05	K313	K68	KCU10	KCU25	KC5010	KC5025	KC5410	KT315
TNMG160408MG	9,53	16,50	0,8	-	-	●	-	-	-	-	-	-	-	-	-	-	-	-	-	-	-	-	-	-	-	-	-	-	-	-	-	-	-	-

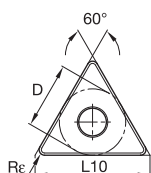
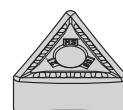

■ TNMG-MS

目录编号	D	L10	Rε	KCP05B	KCP05	KCP10B	KCP10	KCP25B	KCP25	KCP30B	KCP30	KCP40B	KCP40	KCK05B	KCK05	KCK15B	KCK15	KCK20B	KCK20	KCM15B	KCM15	KCM25B	KCM25	KCM35B	KCM35	KCPK05	K313	K68	KCU10	KCU25	KC5010	KC5025	KC5410	KT315
TNMG160402MS	9,53	16,50	0,2	-	-	-	-	-	-	-	-	-	-	-	-	-	-	-	-	-	-	-	-	-	-	-	-	-	-	-	-	-	-	
TNMG160404MS	9,53	16,50	0,4	-	-	-	-	-	-	-	-	-	-	-	-	-	-	-	-	-	-	-	-	-	-	-	-	-	-	-	-	-	-	-
TNMG160408MS	9,53	16,50	0,8	-	-	-	-	-	-	-	-	-	-	-	-	-	-	-	-	-	-	-	-	-	-	-	-	-	-	-	-	-	-	-
TNMG220404MS	12,70	22,00	0,4	-	-	-	-	-	-	-	-	-	-	-	-	-	-	-	-	-	-	-	-	-	-	-	-	-	-	-	-	-	-	-
TNMG220408MS	12,70	22,00	0,8	-	-	-	-	-	-	-	-	-	-	-	-	-	-	-	-	-	-	-	-	-	-	-	-	-	-	-	-	-	-	-
TNMG220412MS	12,70	22,00	1,2	-	-	-	-	-	-	-	-	-	-	-	-	-	-	-	-	-	-	-	-	-	-	-	-	-	-	-	-	-	-	-
TNMG270608MS	15,88	27,50	0,8	-	-	-	-	-	-	-	-	-	-	-	-	-	-	-	-	-	-	-	-	-	-	-	-	-	-	-	-	-	-	-
TNMG270616MS	15,88	27,50	1,6	-	-	-	-	-	-	-	-	-	-	-	-	-	-	-	-	-	-	-	-	-	-	-	-	-	-	-	-	-	-	-

● 首选  
○ 备选

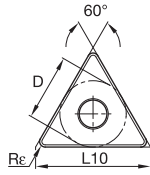
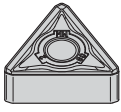

■ TNMG-MW

目录编号	D	L10	Re	KCP05B	KCP05	KCP10B	KCP10	KCP25B	KCP25	KCP30B	KCP30	KCP40B	KCP40	KCK05B	KCK05	KCK15B	KCK15	KCK20B	KCK20	KCM15B	KCM15	KCM25B	KCM25	KCM35B	KCM35	KCPK05	K313	K68	KCU10	KCU25	KC5010	KC5025	KC5410	KT315
TNMG160408MW	9,53	16,50	0,8	-	●	-	-	-	-	-	-	-	-	-	-	-	-	-	-	-	-	-	-	-	-	-	-	-	-	-	-	-	-	-
TNMG160412MW	9,53	16,50	1,2	-	-	●	●	-	●	-	-	-	-	-	-	-	-	-	-	-	-	-	-	-	-	-	-	-	-	-	-	-	-	-

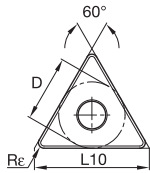
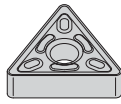

■ TNMG-P

目录编号	D	L10	Re	KCP05B	KCP05	KCP10B	KCP10	KCP25B	KCP25	KCP30B	KCP30	KCP40B	KCP40	KCK05B	KCK05	KCK15B	KCK15	KCK20B	KCK20	KCM15B	KCM15	KCM25B	KCM25	KCM35B	KCM35	KCPK05	K313	K68	KCU10	KCU25	KC5010	KC5025	KC5410	KT315
TNMG160404P	9,53	16,50	0,4	-	-	-	-	-	-	-	-	-	-	-	-	-	-	-	-	-	-	-	-	-	-	-	-	-	-	-	-	-	-	-
TNMG160408P	9,53	16,50	0,8	-	-	-	-	-	-	-	-	-	-	-	-	-	-	-	-	-	-	-	-	-	-	-	-	-	-	-	-	-	-	-
TNMG220404P	12,70	22,00	0,4	-	-	-	-	-	-	-	-	-	-	-	-	-	-	-	-	-	-	-	-	-	-	-	-	-	-	-	-	-	-	-
TNMG220408P	12,70	22,00	0,8	-	-	-	-	-	-	-	-	-	-	-	-	-	-	-	-	-	-	-	-	-	-	-	-	-	-	-	-	-	-	-
TNMG220412P	12,70	22,00	1,2	-	-	-	-	-	-	-	-	-	-	-	-	-	-	-	-	-	-	-	-	-	-	-	-	-	-	-	-	-	-	-

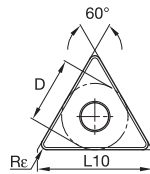

■ TNMG-RN

目录编号	D	L10	Re	KCP05B	KCP05	KCP10B	KCP10	KCP25B	KCP25	KCP30B	KCP30	KCP40B	KCP40	KCK05B	KCK05	KCK15B	KCK15	KCK20B	KCK20	KCM15B	KCM15	KCM25B	KCM25	KCM35B	KCM35	KCPK05	K313	K68	KCU10	KCU25	KC5010	KC5025	KC5410	KT315
TNMG160408RN	9,53	16,50	0,8	-	-	●	●	●	●	-	-	-	-	-	-	-	-	-	-	-	-	-	-	-	-	-	-	-	-	-	-	-	-	-
TNMG160412RN	9,53	16,50	1,2	-	-	●	-	●	●	-	-	-	-	-	-	-	-	-	-	-	-	-	-	-	-	-	-	-	-	-	-	-	-	-
TNMG220408RN	12,70	22,00	0,8	-	-	●	-	●	●	-	-	-	-	-	-	-	-	-	-	-	-	-	-	-	-	-	-	-	-	-	-	-	-	-
TNMG220412RN	12,70	22,00	1,2	-	-	●	-	●	●	-	-	-	-	-	-	-	-	-	-	-	-	-	-	-	-	-	-	-	-	-	-	-	-	-
TNMG220416RN	12,70	22,00	1,6	-	-	-	-	●	●	-	-	-	-	-	-	-	-	-	-	-	-	-	-	-	-	-	-	-	-	-	-	-	-	-
TNMG270608RN	15,88	27,50	0,8	-	-	-	●	●	●	-	-	-	-	-	-	-	-	-	-	-	-	-	-	-	-	-	-	-	-	-	-	-	-	-
TNMG270612RN	15,88	27,50	1,2	-	-	●	●	●	●	-	-	-	-	-	-	-	-	-	-	-	-	-	-	-	-	-	-	-	-	-	-	-	-	-
TNMG270616RN	15,88	27,50	1,6	-	-	●	●	●	●	-	-	-	-	-	-	-	-	-	-	-	-	-	-	-	-	-	-	-	-	-	-	-	-	-
TNMG330924RN	19,05	33,00	2,4	-	-	●	-	●	●	-	-	-	-	-	-	-	-	-	-	-	-	-	-	-	-	-	-	-	-	-	-	-	-	-

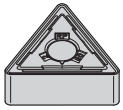

● 首选  
○ 备选

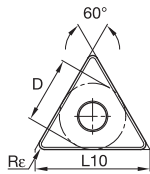

■ TNMG-RP

目录编号	D	L10	Re	KCP05B	KCP05	KCP10B	KCP10	KCP25B	KCP25	KCP30B	KCP30	KCP40B	KCP40	KCK05B	KCK05	KCK15B	KCK15	KCK20B	KCK20	KCM15B	KCM15	KCM25B	KCM25	KCM35B	KCM35	KCPK05	K313	K68	KCU10	KCU25	KC5010	KC5025	KC5410	KT315
TNMG160408RP	9,53	16,50	0,8	-	●	-	-	-	-	-	-	-	-	-	-	-	-	-	-	-	-	-	-	-	-	-	-	-	-	-	-	-	-	-
TNMG160412RP	9,53	16,50	1,2	-	●	-	-	-	-	-	-	-	-	-	-	-	-	-	-	-	-	-	-	-	-	-	-	-	-	-	-	-	-	-
TNMG160416RP	9,53	16,50	1,6	-	-	-	●	-	-	-	-	-	-	-	-	-	-	-	-	-	-	-	-	-	-	-	-	-	-	-	-	-	-	-
TNMG220408RP	12,70	22,00	0,8	-	-	●	-	-	-	-	-	-	-	-	-	-	-	-	-	-	-	-	-	-	-	-	-	-	-	-	-	-	-	-
TNMG220412RP	12,70	22,00	1,2	-	-	-	●	-	-	-	-	-	-	-	-	-	-	-	-	-	-	-	-	-	-	-	-	-	-	-	-	-	-	-
TNMG220416RP	12,70	22,00	1,6	-	-	-	●	-	-	-	-	-	-	-	-	-	-	-	-	-	-	-	-	-	-	-	-	-	-	-	-	-	-	-
TNMG220432RP	12,70	22,00	3,2	-	-	●	-	-	-	-	-	-	-	-	-	-	-	-	-	-	-	-	-	-	-	-	-	-	-	-	-	-	-	-
TNMG270612RP	15,88	27,50	1,2	-	-	-	●	-	-	-	-	-	-	-	-	-	-	-	-	-	-	-	-	-	-	-	-	-	-	-	-	-	-	-
TNMG270616RP	15,88	27,50	1,6	-	-	-	-	●	-	-	-	-	-	-	-	-	-	-	-	-	-	-	-	-	-	-	-	-	-	-	-	-	-	-
TNMG330924RP	19,05	33,00	2,4	-	-	-	-	-	●	-	-	-	-	-	-	-	-	-	-	-	-	-	-	-	-	-	-	-	-	-	-	-	-	-

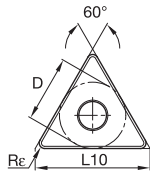

■ TNMG-UN

目录编号	D	L10	Re	KCP05B	KCP05	KCP10B	KCP10	KCP25B	KCP25	KCP30B	KCP30	KCP40B	KCP40	KCK05B	KCK05	KCK15B	KCK15	KCK20B	KCK20	KCM15B	KCM15	KCM25B	KCM25	KCM35B	KCM35	KCPK05	K313	K68	KCU10	KCU25	KC5010	KC5025	KC5410	KT315
TNMG160408UN	9,53	16,50	0,8	-	-	-	-	-	-	-	-	-	-	-	-	-	-	-	-	-	-	-	-	-	-	-	-	-	-	-	-	-	-	-
TNMG160412UN	9,53	16,50	1,2	-	-	-	-	-	-	-	-	-	-	-	-	-	-	-	-	-	-	-	-	-	-	-	-	-	-	-	-	-	-	-
TNMG160416UN	9,53	16,50	1,6	-	-	-	-	-	-	-	-	-	-	-	-	-	-	-	-	-	-	-	-	-	-	-	-	-	-	-	-	-	-	-
TNMG220408UN	12,70	22,00	0,8	-	-	-	-	-	-	-	-	-	-	-	-	-	-	-	-	-	-	-	-	-	-	-	-	-	-	-	-	-	-	-
TNMG220412UN	12,70	22,00	1,2	-	-	-	-	-	-	-	-	-	-	-	-	-	●	-	-	-	-	-	-	-	-	-	-	-	-	-	-	-	-	-
TNMG220416UN	12,70	22,00	1,6	-	-	-	-	-	-	-	-	-	-	-	-	-	-	-	●	-	-	-	-	-	-	-	-	-	-	-	-	-	-	-









ISO 车削刀具

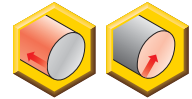
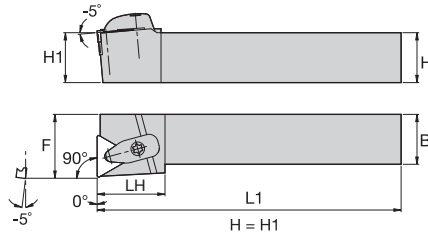
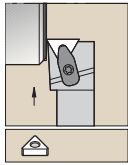

■ DTFN-KC 90°



订货号	目录编号	H	B	F	L1	LH	刀片	垫片	垫片螺钉	Torx Plus	夹具装配件	Torx Plus	槽销	可选择锁定销	
右手															
2273392	DTFNR2020K16KC04	20	20	25,0	125	32,0	TN..160408	ITSN323	KMSP315IP	15 IP	CM234R ASSY	15 IP	SSP025016M	KLM34L9IP	
左手															
1875233	DTFNL2525M22KC04	25	25	32,0	150	34,0	TN..220408	ITSN443	KMSP415IP	15 IP	CM234R ASSY	15 IP	SSP025016M	KLM46L15IP	

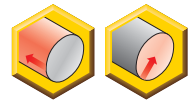
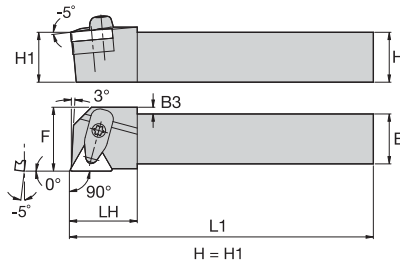
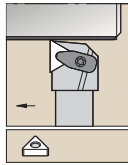

■ DTGN-KC 90°



订货号	目录编号	H	B	F	L1	LH	B3	刀片	垫片	垫片螺钉	Torx Plus	夹具装配件	Torx Plus	槽销	可选择锁定销
右手															
2273440	DTGNR2020K16KC04	20	20	25,0	125	25,0	6,5	TN..160408	ITSN323	KMSP315IP	15 IP	CM234R ASSY	15 IP	SSP025016M	KLM34L9IP
2273441	DTGNR2525M16KC04	25	25	32,0	150	25,0	—	TN..160408	ITSN323	KMSP315IP	15 IP	CM234R ASSY	15 IP	SSP025016M	KLM34L9IP
1875222	DTGNR2525M22KC04	25	25	32,0	150	32,0	3,0	TN..220408	ITSN443	KMSP415IP	15 IP	CM234R ASSY	15 IP	SSP025016M	KLM46L15IP
左手															
1875234	DTGNL2525M22KC04	25	25	32,0	150	32,0	3,0	TN..220408	ITSN443	KMSP415IP	15 IP	CM234R ASSY	15 IP	SSP025016M	KLM46L15IP

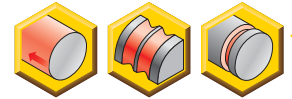
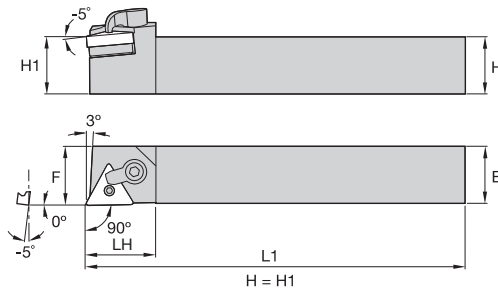
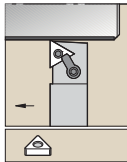

**■ MTAN-S 90°**

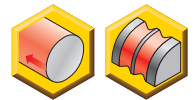
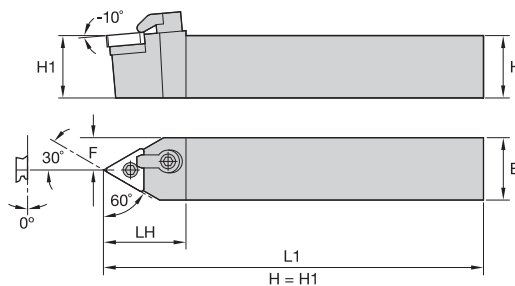
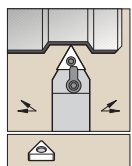
订货号	目录编号	H	B	F	L1	LH	刀片	垫片	锁销	六角	夹具	夹紧螺钉	六角
<b>右手</b>													
1102172	MTANRS2020K16	20	20	20,5	125	32,0	TN..160408	ITSN322	KLM34L	2 mm	CKM21	STCM20	3 mm
1102173	MTANRS2525M16	25	25	25,5	150	30,0	TN..160408	ITSN322	KLM34L	2 mm	CKM21	STCM20	3 mm
<b>左手</b>													
1102726	MTANLS2525M16	25	25	25,5	150	32,0	TN..160408	ITSN322	KLM34L	2 mm	CKM21	STCM20	3 mm

**■ MTEN-S 60°**

订货号	目录编号	H	B	F	L1	LH	刀片	垫片	锁销	六角	夹具	夹紧螺钉	六角
1102169	MTENNS2020K16	20	20	10,0	125	32,0	TN..160408	ITSN322	KLM34L	2 mm	CKM21	STCM20	3 mm
1102170	MTENNS2525M16	25	25	12,0	150	32,0	TN..160408	ITSN322	KLM34L	2 mm	CKM21	STCM20	3 mm
1102171	MTENNS2525M22	25	25	12,0	150	35,0	TN..220408	ITSN433	KLM46	2.5 mm	CKM9	STCM4	4 mm
1102168	MTENNS3225P22	32	25	12,0	170	35,0	TN..220408	ITSN433	KLM46	2.5 mm	CKM9	STCM4	4 mm

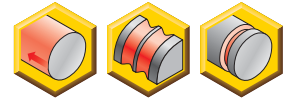
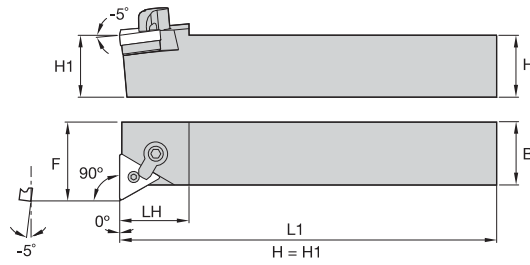
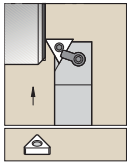
ISO 车削刀具



■ MTFN 90°

订货号	目录编号	H	B	F	L1	LH	刀片	垫片	锁销	六角	夹具	夹紧螺钉	六角
右手													
1101961	MTFN2525M16	25	25	32,0	150	32,0	TN..160408	ITSN322	KLM34L	2 mm	CKM20	STCM11	3 mm
左手													
1102643	MTFNL2020K16	20	20	25,0	125	32,0	TN..160408	ITSN322	KLM34L	2 mm	CKM20	STCM11	3 mm
1102694	MTFNL2525M16	25	25	32,0	150	32,0	TN..160408	ITSN322	KLM34L	2 mm	CKM20	STCM11	3 mm

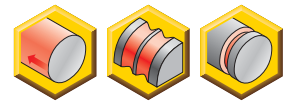
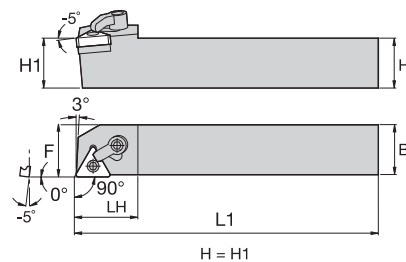
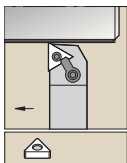

■ MTGN 90°

订货号	目录编号	H	B	F	L1	LH	刀片	垫片	锁销	六角	夹具	夹紧螺钉	六角
右手													
1102091	MTGNR2525M22	25	25	32,0	150	32,0	TN..220408	ITSN433	KLM46	2.5 mm	CKM9	STCM4	4 mm
1102088	MTGNR1616H16	36	25	20,0	100	32,0	TN..160408	ITSN322	KLM34L	2 mm	CKM20	STCM11	3 mm
1102090	MTGNR2525M16	86	32	32,0	150	32,0	TN..160408	ITSN322	KLM34L	2 mm	CKM21	STCM20	3 mm
1102093	MTGNR3232P22	106	32	40,0	170	32,0	TN..220408	ITSN433	KLM46	2.5 mm	CKM9	STCM4	4 mm
左手													
1102714	MTGNL2525M16	86	32	32,0	150	32,0	TN..160408	ITSN322	KLM34L	2 mm	CKM21	STCM20	3 mm
1102715	MTGNL2525M22	86	38	32,0	150	32,0	TN..220408	ITSN433	KLM46	2.5 mm	CKM9	STCM4	4 mm
1102716	MTGNL3232P22	106	25	40,0	170	32,0	TN..220408	ITSN433	KLM46	2.5 mm	CKM9	STCM4	4 mm

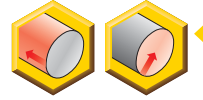
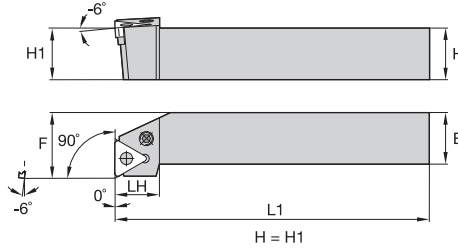
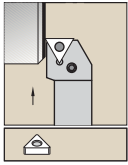
**PTFN 90°**

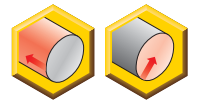
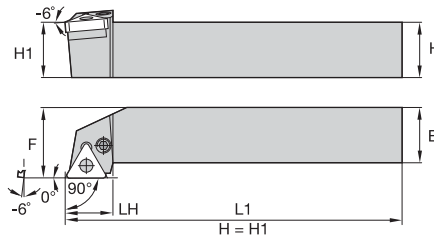
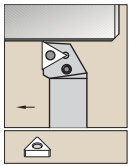

订货号	目录编号	H	B	F	L1	LH	刀片	垫片	垫片销	冲头	杠杆	杠杆螺钉	六角
<b>右手</b>													
1244843	PTFNR2020K16	20	20	25,0	125	20,0	TN..160408	512.013	513.018	515.018	511.018	514.118	10 IP
1244844	PTFNR2525M16	25	25	32,0	150	20,0	TN..160408	512.013	513.018	515.018	511.018	514.118	10 IP
<b>左手</b>													
1244839	PTFNL2020K16	20	20	25,0	125	20,0	TN..160408	512.013	513.018	515.018	511.018	514.118	10 IP
1244726	PTFNL2525M16	25	25	32,0	150	20,0	TN..160408	512.013	513.018	515.018	511.018	514.118	10 IP

**PTGN 90°**

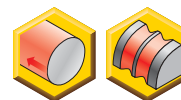
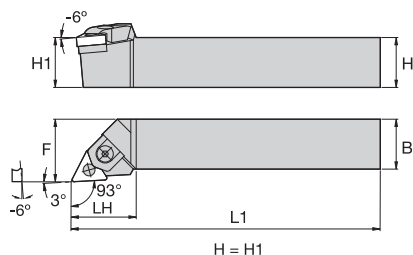
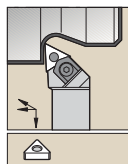
订货号	目录编号	H	B	F	L1	LH	刀片	垫片	垫片销	冲头	杠杆	杠杆螺钉	六角
<b>右手</b>													
1156972	PTGNR1616H16	16	16	20,0	100	20,0	TN..160408	512.013	513.018	515.018	511.018	514.118	10 IP
1244850	PTGNR2020K16	20	20	25,0	125	20,0	TN..160408	512.013	513.018	515.018	511.018	514.118	10 IP
1192394	PTGNR2525M16	25	25	32,0	150	20,0	TN..160408	512.013	513.018	515.018	511.018	514.118	10 IP
1244851	PTGNR2525M22	25	25	32,0	150	26,0	TN..220408	512.023	513.023	515.018	511.023	514.123	15 IP
<b>左手</b>													
1244791	PTGNL1616H16	16	16	20,0	100	20,0	TN..160408	512.013	513.018	515.018	511.018	514.118	10 IP
1244848	PTGNL2020K16	20	20	25,0	125	20,0	TN..160408	512.013	513.018	515.018	511.018	514.118	10 IP
1244792	PTGNL2525M16	25	25	32,0	150	20,0	TN..160408	512.013	513.018	515.018	511.018	514.118	10 IP
1244778	PTGNL2525M22	25	25	32,0	150	26,0	TN..220408	512.023	513.023	515.018	511.023	514.123	15 IP

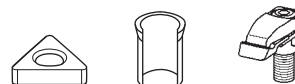

■ MTJN 93°



订货号	目录编号	H	B	F	L1	LH	刀片	垫片	垫片销	夹具装配件	六角
右手											
1192350	MTJNR2020K16H4	20	20	25,0	125	32,0	TN..160408	512.125	513.125	551.125	3 mm
1192352	MTJNR2525M16H4	25	25	32,0	150	32,0	TN..160408	512.125	513.125	551.125	3 mm
1245000	MTJNR2525M22H4	25	25	32,0	150	36,0	TN..220408	512.126	513.126	551.126	3 mm
1244998	MTJNR3225P16H4	32	25	32,0	170	32,0	TN..160408	512.125	513.125	551.125	3 mm
1244999	MTJNR3225P22H4	32	25	32,0	170	36,0	TN..220408	512.126	513.126	551.126	3 mm
左手											
1244996	MTJNL2020K16H4	20	20	25,0	125	32,0	TN..160408	512.125	513.125	551.125	3 mm
1245002	MTJNL2525M16H4	25	25	32,0	150	32,0	TN..160408	512.125	513.125	551.125	3 mm
1245001	MTJNL2525M22H4	25	25	32,0	150	36,0	TN..220408	512.126	513.126	551.126	3 mm
1244997	MTJNL3225P16H4	32	25	32,0	170	32,0	TN..160408	512.125	513.125	551.125	3 mm





带有内冷的钢刀柄。

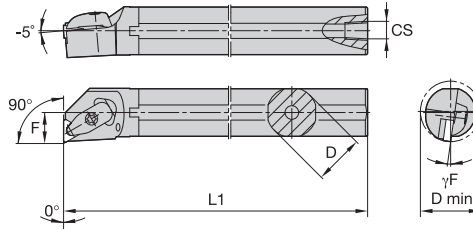

ISO 车削刀具

■ A-DTFN-KC 90°

订货号	目录编号	D	D min	F	L1	CS	γF°	刀片	垫片	垫片螺钉	Torx Plus	夹具装配件	槽销	Torx Plus
右手														
2441866	A25RDTFNR16KC04	25	32,0	17,0	200	1/4-18 NPT	-14.0	TN..160408	ITSN323	KMSP315IP	15 IP	CM234R ASSY	SSP025016M	15 IP
2441870	A32SDTFNR16KC04	32	40,0	22,0	250	1/4-18 NPT	-12.0	TN..160408	ITSN323	KMSP315IP	15 IP	CM234R ASSY	SSP025016M	15 IP
左手														
2441869	A25RDTFNL16KC04	25	32,0	17,0	200	1/4-18 NPT	-14.0	TN..160408	ITSN323	KMSP315IP	15 IP	CM234R ASSY	SSP025016M	15 IP

Kenloc™ 镗杆



带有内冷的钢刀柄。

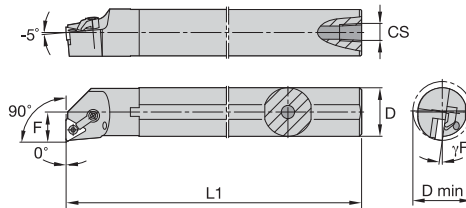

■ A-MTFN 90°

订货号	目录编号	D	D min	F	L1	CS	γF°	刀片	垫片	锁销	六角	夹具	夹紧螺钉	六角
右手														
1098121	A25RMTFNR16	25	32,0	17,0	200	1/4-18 NPT	-14.0	TN..160408	ITSN322	KLM34L	2 mm	CKM21	STCM20	3 mm
1098123	A32SMTFNR16	32	40,0	22,0	250	1/4-18 NPT	-12.0	TN..160408	ITSN322	KLM34L	2 mm	CKM21	STCM20	3 mm
1098125	A40TMTFNR16	40	50,0	27,0	300	1/4-18 NPT	-9.0	TN..160408	ITSN322	KLM34L	2 mm	CKM21	STCM20	3 mm
左手														
1098122	A25RMTFNL16	25	32,0	17,0	200	1/4-18 NPT	-14.0	TN..160408	ITSN322	KLM34L	2 mm	CKM21	STCM20	3 mm
1098124	A32SMTFNL16	32	40,0	22,0	250	1/4-18 NPT	-12.0	TN..160408	ITSN322	KLM34L	2 mm	CKM21	STCM20	3 mm

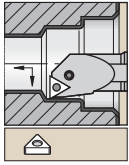

带内冷功能的钢质刀柄。

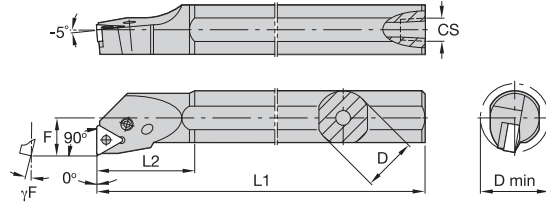

■ A-PTFN 90°

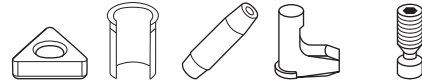

订货号	目录编号	D	D min	F	L1	L2	CS	$\gamma_F^\circ$	刀片	垫片	垫片销	销	杠杆	杠杆螺钉	Torx Plus
右手															
2447535	A16RPTFNR11	16	20,0	11,0	200	28	1/8-27 NPT	-14,0	TN..110304	-	-	-	511.011	514.111	8 IP
2447536	A20SPTFNR11	20	25,0	13,0	250	30	1/8-27 NPT	-12,0	TN..110304	-	-	-	511.011	514.111	8 IP
2447537	A25TPTFNR16	25	32,0	17,0	300	40	1/4-18 NPT	-12,0	TN..160408	512.013	513.018	515.018	511.018	514.118	10 IP
2447539	A32UPTFNR16	32	40,0	22,0	350	50	1/4-18 NPT	-10,0	TN..160408	512.013	513.018	515.018	511.018	514.118	10 IP
2447504	A40VPTFNR22	40	48,0	27,0	400	55	1/4-18 NPT	-10,0	TN..220408	512.023	513.023	515.018	511.023	514.123	15 IP
左手															
2447489	A20SPTFNL11	20	25,0	13,0	250	30	1/8-27 NPT	-12,0	TN..110304	-	-	-	511.011	514.111	8 IP
2447538	A25TPTFNL16	25	32,0	17,0	300	40	1/4-18 NPT	-12,0	TN..160408	512.013	513.018	515.018	511.018	514.118	10 IP
2447503	A32UPTFNL16	32	40,0	22,0	350	50	1/4-18 NPT	-10,0	TN..160408	512.013	513.018	515.018	511.018	514.118	10 IP

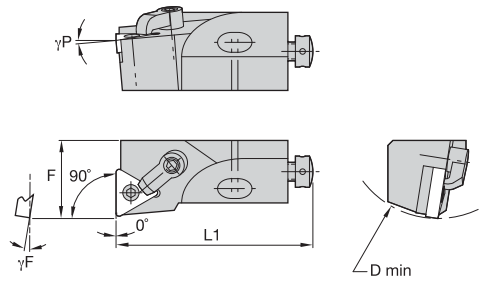
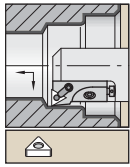
**■ MTFN 90°**

订货号	目录编号	D min	F	L1	γF°	γP°	刀片
<b>右手</b>							
2078236	MTFNR12CA16	50	20,0	55	-9.0	-5.0	TN..160408/TN..332
2074429	MTFNR16CA16	60	25,0	63	-9.0	-5.0	TN..160408/TN..332
3330208	MTFNR20CA22	70	25,0	70	-9.0	-5.0	TN..220408/TN..432
<b>左手</b>							
2057426	MTFNL12CA16	50	20,0	55	-9.0	-5.0	TN..160408/TN..332
2193621	MTFNL16CA16	60	25,0	63	-9.0	-5.0	TN..160408/TN..332
3330207	MTFNL20CA22	70	25,0	70	-9.0	-5.0	TN..220408/TN..432

**■ 配件**

D min	垫片	锁销	六角	夹具	夹紧螺钉	六角	径向调节螺钉	六角	轴向调整螺钉	安装螺钉	六角	垫片
50	—	KLM33L	2 mm	CKM34	STCM38	2 mm	KUAM22	2 mm	KUAM31	191.406	4 mm	CSWM 060 050
60	ITSN322	KLM34L	2 mm	CKM34	STCM9	2 mm	KUAM25	2 mm	KUAM32	191.407	5 mm	CSWM 080 050
70	ITSN433	KLM46	2.5 mm	CKM35	STCM37	2.5 mm	KUAM25	2.5 mm	KUAM32	191.407	5 mm	CSWM 080 050

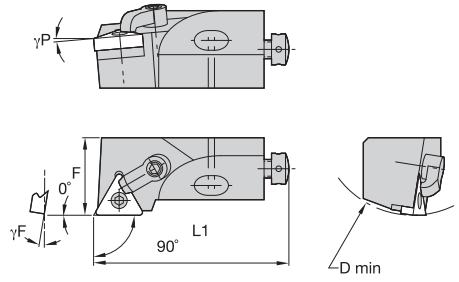

■ MTGN 90°

订货号	目录编号	D min	F	L1	$\gamma_F^\circ$	$\gamma_P^\circ$	刀片
右手							
2114041	MTGNR12CA16	50	20,0	55	-9.0	-5.0	TN..160408/TN..332
3330285	MTGNR16CA16	60	25,0	63	-9.0	-5.0	TN..160408/TN..332
左手							
3346275	MTGNL12CA16	50	20,0	55	-9.0	-5.0	TN..160408/TN..332
3330209	MTGNL20CA22	70	25,0	70	-9.0	-5.0	TN..220408/TN..432

■ 配件



D min	垫片	锁销	六角	夹具	夹紧螺钉	六角	径向调节螺钉	六角	轴向调节螺钉	安装螺钉	六角	垫片
50	—	KLM33L	2 mm	CKM34	STCM38	2 mm	KUAM22	2 mm	KUAM31	191.406	4 mm	CSWM 060 050
60	ITSN322	KLM34L	2 mm	CKM34	STCM9	2.5 mm	KUAM25	2.5 mm	KUAM32	191.407	5 mm	CSWM 080 050
70	ITSN433	KLM46	2.5 mm	CKM35	STCM37	2.5 mm	KUAM25	2.5 mm	KUAM32	191.407	5 mm	CSWM 080 050

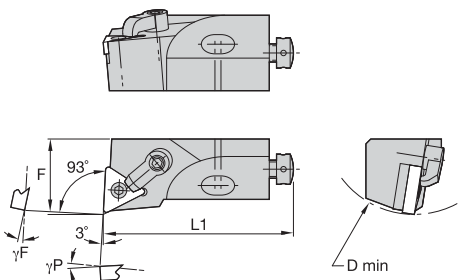
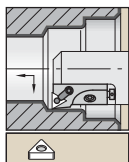

### ■ MTUN 93°

订货号	目录编号	D min	F	L1	γF°	γP°	刀片
右手							
1098536	MTUNR20CA22	70	25,0	70	-9.0	-5.0	TN..220408/TN..432
左手							
1098529	MTUNL12CA16	50	20,0	55	-9.0	-5.0	TN..160408/TN..332
1098535	MTUNL16CA16	60	25,0	63	-9.0	-5.0	TN..160408/TN..332

注: 根据 D 最小值和已选刀片尺寸选择配件产品。

### ■ 配件



D min	垫片	锁销	六角	夹具	夹紧螺钉	六角	径向调节螺钉	六角	轴向调整螺钉	安装螺钉	六角	垫片
50	—	KLM33L	2 mm	CKM34	STCM38	2 mm	KUAM22	2 mm	KUAM31	191.406	4 mm	CSWM 060 050
60	ITSN322	KLM34L	2 mm	CKM34	STCM9	2.5 mm	KUAM25	2.5 mm	KUAM32	191.407	5 mm	CSWM 080 050
70	ITSN433	KLM46	—	CKM35	STCM37	2.5 mm	KUAM25	2.5 mm	KUAM33	191.407	5 mm	CSWM 080 050

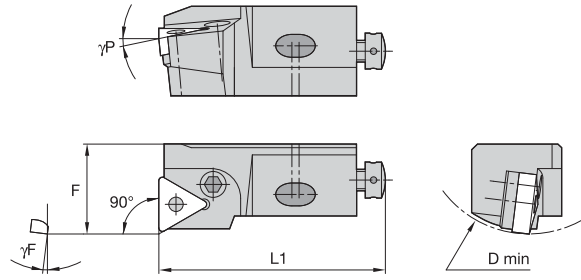
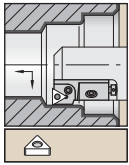

■ PTFN 90°

订货号	目录编号	D min	F	L1	γF°	γP°	刀片
右手							
1188641	PTFNR12CA-16	50	20,0	55	-7.0	-6.0	TN..160408/TN..332
左手							
1244457	PTFNL12CA-16	50	20,0	55	-7.0	-6.0	TN..160408/TN..332

■ 配件



D min	杠杆	杠杆螺钉	扳手尺寸调整杆 螺钉	径向调节螺钉	六角	轴向调整螺钉	安装螺钉	六角	垫片
50	511.030	514.112	8 IP	KUAM28	2 mm	KUAM31	191.406	4 mm	CSWM 060 050

● 首选  
○ 备选

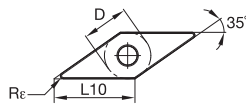
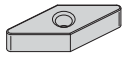

■ VNGA

目录编号	D	L10	Re	KCP05B	KCP05	KCP10B	KCP10	KCP25B	KCP25	KCP30B	KCP30	KCP40B	KCP40	KCK05B	KCK05	KCK15B	KCK15	KCK20B	KCK20	KCM15B	KCM15	KCM25B	KCM25	KCM35B	KCM35	KCPK05	K313	K68	KCU10	KCU25	KC5010	KC5025	KC5410	KT315
VNGA160404	9,53	16,61	0,4	-	-	-	-	-	-	-	-	-	-	-	-	-	-	-	-	-	-	-	-	-	-	-	-	-	-	-	-	-	-	-
VNGA160408	9,53	16,61	0,8	-	-	-	-	-	-	-	-	-	-	-	-	-	-	-	-	-	-	-	-	-	-	-	-	-	-	-	-	-	-	-

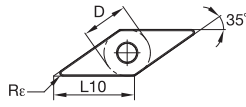
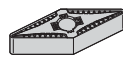

■ VNGG-FS

目录编号	D	L10	Re	KCP05B	KCP05	KCP10B	KCP10	KCP25B	KCP25	KCP30B	KCP30	KCP40B	KCP40	KCK05B	KCK05	KCK15B	KCK15	KCK20B	KCK20	KCM15B	KCM15	KCM25B	KCM25	KCM35B	KCM35	KCPK05	K313	K68	KCU10	KCU25	KC5010	KC5025	KC5410	KT315
VNGG160401FS	9,53	16,61	0,1	-	-	-	-	-	-	-	-	-	-	-	-	-	-	-	-	-	-	-	-	-	-	-	-	-	-	-	-	-	-	-
VNGG160402FS	9,53	16,61	0,2	-	-	-	-	-	-	-	-	-	-	-	-	-	-	-	-	-	-	-	-	-	-	-	-	-	-	-	-	-	-	-
VNGG160404FS	9,53	16,61	0,4	-	-	-	-	-	-	-	-	-	-	-	-	-	-	-	-	-	-	-	-	-	-	-	-	-	-	-	-	-	-	-
VNGG160408FS	9,53	16,61	0,8	-	-	-	-	-	-	-	-	-	-	-	-	-	-	-	-	-	-	-	-	-	-	-	-	-	-	-	-	-	-	-

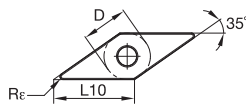
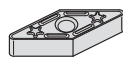

■ VNGG-LF

目录编号	D	L10	Re	KCP05B	KCP05	KCP10B	KCP10	KCP25B	KCP25	KCP30B	KCP30	KCP40B	KCP40	KCK05B	KCK05	KCK15B	KCK15	KCK20B	KCK20	KCM15B	KCM15	KCM25B	KCM25	KCM35B	KCM35	KCPK05	K313	K68	KCU10	KCU25	KC5010	KC5025	KC5410	KT315
VNGG160402LF	9,53	16,61	0,2	-	-	-	-	-	-	-	-	-	-	-	-	-	-	-	-	-	-	-	-	-	-	-	-	-	-	-	-	-	-	-
VNGG160404LF	9,53	16,61	0,4	-	-	-	-	-	-	-	-	-	-	-	-	-	-	-	-	-	-	-	-	-	-	-	-	-	-	-	-	-	-	-
VNGG160408LF	9,53	16,61	0,8	-	-	-	-	-	-	-	-	-	-	-	-	-	-	-	-	-	-	-	-	-	-	-	-	-	-	-	-	-	-	-
VNGG220408LF	12,70	22,14	0,8	-	-	-	-	-	-	-	-	-	-	-	-	-	-	-	-	-	-	-	-	-	-	-	-	-	-	-	-	-	-	-

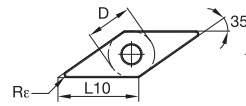
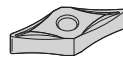

■ VNGP

目录编号	D	L10	Re	KCP05B	KCP05	KCP10B	KCP10	KCP25B	KCP25	KCP30B	KCP30	KCP40B	KCP40	KCK05B	KCK05	KCK15B	KCK15	KCK20B	KCK20	KCM15B	KCM15	KCM25B	KCM25	KCM35B	KCM35	KCPK05	K313	K68	KCU10	KCU25	KC5010	KC5025	KC5410	KT315
VNGP160401	9,53	16,61	0,1	-	-	-	-	-	-	-	-	-	-	-	-	-	-	-	-	-	-	-	-	-	-	-	-	-	-	-	-	-	-	-
VNGP160402	9,53	16,61	0,2	-	-	-	-	-	-	-	-	-	-	-	-	-	-	-	-	-	-	-	-	-	-	-	-	-	-	-	-	-	-	-
VNGP220404	12,70	22,14	0,4	-	-	-	-	-	-	-	-	-	-	-	-	-	-	-	-	-	-	-	-	-	-	-	-	-	-	-	-	-	-	-
VNGP220408	12,70	22,14	0,8	-	-	-	-	-	-	-	-	-	-	-	-	-	-	-	-	-	-	-	-	-	-	-	-	-	-	-	-	-	-	-





● 首选  
○ 备选

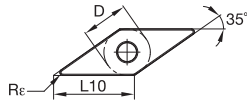
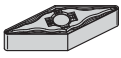

■ VNMG-FF

目录编号	D	L10	Re	KCP05B	KCP05	KCP10B	KCP10	KCP25B	KCP25	KCP30B	KCP30	KCP40B	KCP40	KCK05B	KCK05	KCK15B	KCK15	KCK20B	KCK20	KCM15B	KCM15	KCM25B	KCM25	KCM35B	KCM35	KCPK05	K313	K68	KCU10	KCU25	KC5010	KC5025	KC5410	KT315
VNMG160404FF	9,53	16,61	0,4	-	●	●	●	-	-	-	-	-	-	-	-	-	-	-	-	●	-	-	-	-	-	-	-	-	-	-	-	-	-	-
VNMG160408FF	9,53	16,61	0,8	-	●	●	●	-	-	-	-	-	-	-	-	-	-	-	-	-	-	-	-	-	-	-	-	-	-	-	-	-	-	-

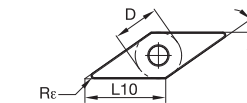
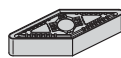

■ VNMG-FN

目录编号	D	L10	Re	KCP05B	KCP05	KCP10B	KCP10	KCP25B	KCP25	KCP30B	KCP30	KCP40B	KCP40	KCK05B	KCK05	KCK15B	KCK15	KCK20B	KCK20	KCM15B	KCM15	KCM25B	KCM25	KCM35B	KCM35	KCPK05	K313	K68	KCU10	KCU25	KC5010	KC5025	KC5410	KT315
VNMG160404FN	9,53	16,61	0,4	-	●	●	●	●	●	-	-	-	-	-	●	●	-	-	-	-	-	-	-	-	-	-	-	-	-	-	-	-	-	-
VNMG160408FN	9,53	16,61	0,8	-	●	●	●	●	●	-	-	-	-	-	●	●	-	-	-	-	-	-	-	-	-	-	-	-	-	-	-	-	-	-

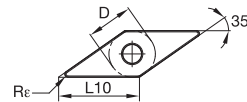

■ VNMG-FP

目录编号	D	L10	Re	KCP05B	KCP05	KCP10B	KCP10	KCP25B	KCP25	KCP30B	KCP30	KCP40B	KCP40	KCK05B	KCK05	KCK15B	KCK15	KCK20B	KCK20	KCM15B	KCM15	KCM25B	KCM25	KCM35B	KCM35	KCPK05	K313	K68	KCU10	KCU25	KC5010	KC5025	KC5410	KT315
VNMG160404FP	9,53	16,61	0,4	-	-	-	-	-	-	-	-	-	-	-	-	-	-	-	-	-	●	-	-	-	-	-	-	-	-	-	-	-	-	
VNMG160408FP	9,53	16,61	0,8	-	-	-	-	●	●	-	-	-	-	-	-	-	-	-	-	-	●	-	-	-	-	-	-	-	-	-	-	-	-	-

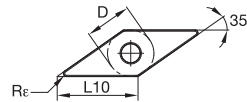
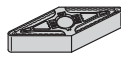

■ VNMG-MN

目录编号	D	L10	Re	KCP05B	KCP05	KCP10B	KCP10	KCP25B	KCP25	KCP30B	KCP30	KCP40B	KCP40	KCK05B	KCK05	KCK15B	KCK15	KCK20B	KCK20	KCM15B	KCM15	KCM25B	KCM25	KCM35B	KCM35	KCPK05	K313	K68	KCU10	KCU25	KC5010	KC5025	KC5410	KT315
VNMG160404MN	9,53	16,61	0,4	-	-	-	-	●	●	●	●	-	-	-	-	-	-	-	-	-	-	-	-	-	-	-	-	-	-	-	-	-	-	-
VNMG160408MN	9,53	16,61	0,8	●	●	●	●	●	●	●	●	-	-	-	-	-	-	-	-	-	-	-	-	-	-	-	-	-	-	-	-	-	-	-
VNMG160412MN	9,53	16,61	1,2	-	-	-	-	●	●	●	●	-	-	-	-	-	-	-	-	-	-	-	-	-	-	-	-	-	-	-	-	-	-	-



● 首选  
○ 备选

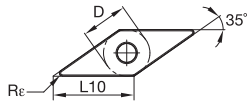
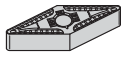

■ VNMG-RN

目录编号	D	L10	Re	KCP05B	KCP05	KCP10B	KCP10	KCP25B	KCP25	KCP30B	KCP30	KCP40B	KCP40	KCK05B	KCK05	KCK15B	KCK15	KCK20B	KCK20	KCM15B	KCM15	KCM25B	KCM25	KCM35B	KCM35	KCPK05	K313	K68	KCU10	KCU25	KC5010	KC5025	KC5410	KT315
VNMG160408RN	9,53	16,61	0,8	-	-	●	●	●	●	-	-	-	-	-	-	-	-	-	-	-	-	-	-	-	-	-	-	-	-	-	-	-	-	-
VNMG160412RN	9,53	16,61	1,2	-	-	●	●	●	●	-	-	-	-	-	-	-	-	-	-	-	-	-	-	-	-	-	-	-	-	-	-	-	-	-
VNMG220408RN	12,70	22,14	0,8	-	-	●	●	●	●	-	-	-	●	-	-	-	-	-	-	-	-	-	-	-	-	-	-	-	-	-	-	-	-	-
VNMG220412RN	12,70	22,14	1,2	-	-	●	●	●	●	-	-	●	-	-	-	-	-	-	-	-	-	-	-	-	-	-	-	-	-	-	-	-	-	-

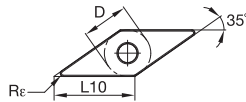
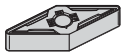

■ VNMG-RP

目录编号	D	L10	Re	KCP05B	KCP05	KCP10B	KCP10	KCP25B	KCP25	KCP30B	KCP30	KCP40B	KCP40	KCK05B	KCK05	KCK15B	KCK15	KCK20B	KCK20	KCM15B	KCM15	KCM25B	KCM25	KCM35B	KCM35	KCPK05	K313	K68	KCU10	KCU25	KC5010	KC5025	KC5410	KT315
VNMG160408RP	9,53	16,61	0,8	-	-	●	●	●	●	-	-	-	-	-	-	-	●	●	●	-	-	-	-	-	-	-	-	-	-	-	-	-	-	-
VNMG160412RP	9,53	16,61	1,2	-	-	●	●	●	●	-	-	-	-	-	-	-	●	●	●	-	-	-	-	-	-	-	-	-	-	-	-	-	-	-

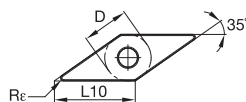

■ VNMG-UN

目录编号	D	L10	Re	KCP05B	KCP05	KCP10B	KCP10	KCP25B	KCP25	KCP30B	KCP30	KCP40B	KCP40	KCK05B	KCK05	KCK15B	KCK15	KCK20B	KCK20	KCM15B	KCM15	KCM25B	KCM25	KCM35B	KCM35	KCPK05	K313	K68	KCU10	KCU25	KC5010	KC5025	KC5410	KT315
VNMG160404UN	9,53	16,61	0,4	-	-	-	-	-	-	-	-	-	-	-	-	-	●	●	●	-	-	-	-	-	-	-	-	-	-	-	-	-	-	-
VNMG160408UN	9,53	16,61	0,8	-	-	-	-	-	-	-	-	-	-	-	-	-	●	●	●	-	-	-	-	-	-	-	-	-	-	-	-	-	-	-

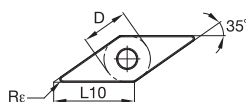

■ VNMG-UP

目录编号	D	L10	Re	KCP05B	KCP05	KCP10B	KCP10	KCP25B	KCP25	KCP30B	KCP30	KCP40B	KCP40	KCK05B	KCK05	KCK15B	KCK15	KCK20B	KCK20	KCM15B	KCM15	KCM25B	KCM25	KCM35B	KCM35	KCPK05	K313	K68	KCU10	KCU25	KC5010	KC5025	KC5410	KT315
VNMG160404UP	9,53	16,61	0,4	-	-	-	-	-	-	-	-	-	-	-	-	-	-	-	-	-	-	-	-	-	-	-	-	-	-	-	-	-	-	
VNMG160408UP	9,53	16,61	0,8	-	-	-	-	-	-	-	-	-	-	-	-	-	-	-	-	-	-	-	-	-	-	-	-	-	-	-	-	-	-	-
VNMG160412UP	9,53	16,61	1,2	-	-	-	-	-	-	-	-	-	-	-	-	-	-	-	-	-	-	-	-	-	-	-	-	-	-	-	-	-	-	-



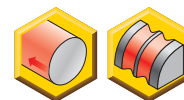
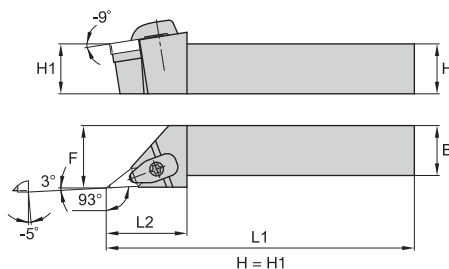
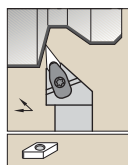

ISO 车削刀具

**■ DVJN-KC 93°**

订货号	目录编号	H	B	F	L1	LH	刀片	垫片	垫片螺钉	Torx Plus	夹具装配件	Torx Plus	槽销	可选择锁定销	
<b>右手</b>															
2439399	DVJNR2020K16KC04	20	20	25,0	125	46,0	VN..160408	IVSN322	KMSP315IP	15 IP	CM215R ASSY	15 IP	SSP025016M	KLM34L9IP	
2439401	DVJNR2525M16KC04	25	25	32,0	150	46,0	VN..160408	IVSN322	KMSP315IP	15 IP	CM215R ASSY	15 IP	SSP025016M	KLM34L9IP	
2439443	DVJNR3225P16KC04	32	25	32,0	170	46,0	VN..160408	IVSN322	KMSP315IP	15 IP	CM215R ASSY	15 IP	SSP025016M	KLM34L9IP	
<b>左手</b>															
2439400	DVJNL2020K16KC04	20	20	25,0	125	46,0	VN..160408	IVSN322	KMSP315IP	15 IP	CM215R ASSY	15 IP	SSP025016M	KLM34L9IP	
2439402	DVJNL2525M16KC04	25	25	32,0	150	46,0	VN..160408	IVSN322	KMSP315IP	15 IP	CM215R ASSY	15 IP	SSP025016M	KLM34L9IP	
2439444	DVJNL3225P16KC04	32	25	32,0	170	46,0	VN..160408	IVSN322	KMSP315IP	15 IP	CM215R ASSY	15 IP	SSP025016M	KLM34L9IP	

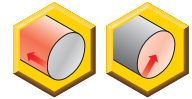
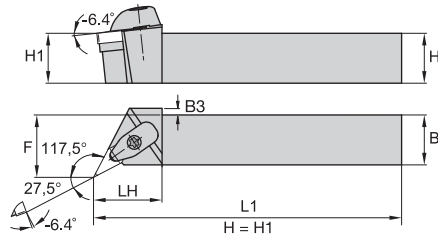
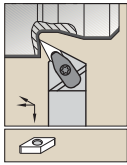

■ DVON-KC 117,5°

订货号	目录编号	H	B	F	L1	LH	B3	刀片	垫片	垫片螺钉	Torx Plus	夹具装配件	Torx Plus	槽销	可选择锁定销
右手															
2439449	DVONR2020K16KC04	20	20	27,0	125	38,0	5,0	VN..160408	IVSN322	KMSP315IP	15 IP	CM215R ASSY	15 IP	SSP025016M	KLM34L9IP
2439451	DVONR2525M16KC04	25	25	32,0	150	38,0	—	VN..160408	IVSN322	KMSP315IP	15 IP	CM215R ASSY	15 IP	SSP025016M	KLM34L9IP
2439453	DVONR3225P16KC04	32	25	32,0	170	38,0	—	VN..160408	IVSN322	KMSP315IP	15 IP	CM215R ASSY	15 IP	SSP025016M	KLM34L9IP
左手															
2439450	DVONL2020K16KC04	20	20	27,0	125	38,0	5,0	VN..160408	IVSN322	KMSP315IP	15 IP	CM215R ASSY	15 IP	SSP025016M	KLM34L9IP
2439452	DVONL2525M16KC04	25	25	32,0	150	38,0	—	VN..160408	IVSN322	KMSP315IP	15 IP	CM215R ASSY	15 IP	SSP025016M	KLM34L9IP
2439454	DVONL3225P16KC04	32	25	32,0	170	38,0	—	VN..160408	IVSN322	KMSP315IP	15 IP	CM215R ASSY	15 IP	SSP025016M	KLM34L9IP

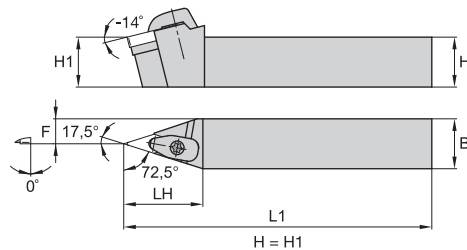
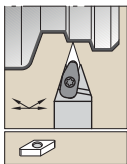

■ DVVN-KC 72,5°

订货号	目录编号	H	B	F	L1	LH	刀片	垫片	垫片螺钉	Torx Plus	夹具装配件	Torx Plus	槽销	可选择锁定销
2439455	DVVNN2020K16KC04	20	20	10,0	150	48,0	VN..160408	IVSN322	KMSP315IP	15 IP	CM215R ASSY	15 IP	SSP025016M	KLM34L9IP
2439456	DVVNN2525M16KC04	25	25	12,0	150	48,0	VN..160408	IVSN322	KMSP315IP	15 IP	CM215R ASSY	15 IP	SSP025016M	KLM34L9IP

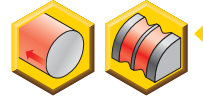
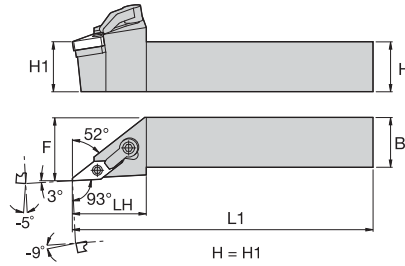
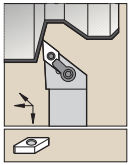
**MVJN 93°**

订货号	目录编号	H	B	F	L1	LH	刀片	垫片	锁销	六角	夹具	夹紧螺钉	六角
<b>右手</b>													
1101362	MVJNR2020K16	20	20	25,0	125	37,0	VN..160408	IVSN322	KLM34L	2 mm	CKM31	STCM20	3 mm
1101634	MVJNR2525M16	25	25	32,0	150	37,0	VN..160408	IVSN322	KLM34L	2 mm	CKM31	STCM20	3 mm
1101363	MVJNR3225P16	32	25	32,0	170	37,0	VN..160408	IVSN322	KLM34L	2 mm	CKM31	STCM20	3 mm
1101635	MVJNR3225P22	32	25	32,0	170	50,0	VN..220408	IVSN432	KLM46	2.5 mm	CKM26	STCM4	4 mm
3612649	MVJNR3232P16	32	32	40,5	171	37,0	VN..160408	IVSN322	KLM34L	2 mm	CKM31	STCM20	3 mm
<b>左手</b>													
1102320	MVJNL2020K16	20	20	25,0	125	37,0	VN..160408	IVSN322	KLM34L	2 mm	CKM31	STCM20	3 mm
1102321	MVJNL2525M16	25	25	32,0	150	37,0	VN..160408	IVSN322	KLM34L	2 mm	CKM31	STCM20	3 mm
1102322	MVJNL3225P16	32	25	32,0	170	37,0	VN..160408	IVSN322	KLM34L	2 mm	CKM31	STCM20	3 mm
1102323	MVJNL3225P22	32	25	32,0	170	50,0	VN..220408	IVSN432	KLM46	2.5 mm	CKM26	STCM4	4 mm
3612650	MVJNL3232P16	32	32	40,5	170	37,0	VN..160408	IVSN322	KLM34L	2 mm	CKM31	STCM20	3 mm

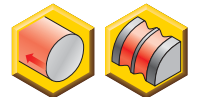
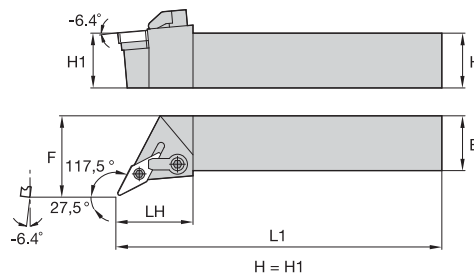
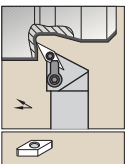
**MVON 117,5°**

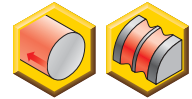
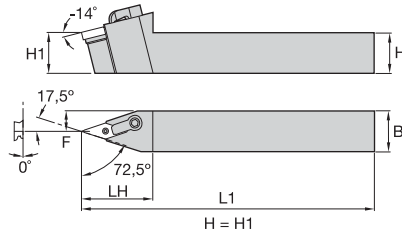
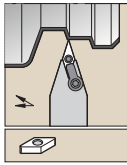

订货号	目录编号	H	B	F	L1	LH	刀片	垫片	锁销	六角	夹具	夹紧螺钉	六角
<b>右手</b>													
1102238	MVONR2525M16	25	25	32,0	150	30,0	VN..160408	IVSN322	KLM34L	2 mm	CKM6	STCM5	2.5 mm
<b>左手</b>													
1102730	MVONL2525M16	25	25	32,0	150	30,0	VN..160408	IVSN322	KLM34L	2 mm	CKM6	STCM5	2.5 mm



■ MVVN 72,5°

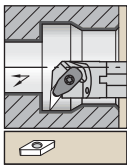

订货号	目录编号	H	B	F	L1	LH	刀片	垫片	锁销	六角	夹具	夹紧螺钉	六角
1102723	MVVNN2525M22	25	25	12,0	150	55,0	VN..220408	IVSN432	KLM46	2.5 mm	CKM26	STCM4	4 mm
1102720	MVVNN2020K16	42	20	10,0	125	42,0	VN..160408	IVSN322	KLM34L	2 mm	CKM31	STCM20	3 mm
1102721	MVVNN2525M16	66	25	12,5	150	42,0	VN..160408	IVSN322	KLM34L	2 mm	CKM31	STCM20	3 mm
1102722	MVVNN3225P16	86	32	12,5	170	42,0	VN..160408	IVSN322	KLM34L	2 mm	CKM31	STCM20	3 mm



带有内冷的钢刀柄。

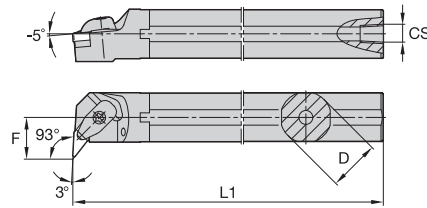

■ A-DVUN-KC 93°



订货号	目录编号	D	D min	F	L1	CS	γF°	刀片	垫片	垫片螺钉	Torx Plus	夹具装配件	槽销	Torx Plus
右手														
2441916	A32SDVUNR16KC04	32	40,0	22,0	250	1/4-18 NPT	-9,0	VN..160408	IVSN322	KMSP315IP	15 IP	CM234R ASSY	SSP025016M	15 IP
2441918	A40TDVUNR16KC04	40	50,0	27,0	300	1/4-18 NPT	-8,0	VN..160408	IVSN322	KMSP315IP	15 IP	CM215R ASSY	SSP025016M	15 IP
左手														
2441917	A32SDVUNL16KC04	32	40,0	22,0	250	1/4-18 NPT	-9,0	VN..160408	IVSN322	KMSP315IP	15 IP	CM234R ASSY	SSP025016M	15 IP
2441919	A40TDVUNL16KC04	40	50,0	27,0	300	1/4-18 NPT	-8,0	VN..160408	IVSN322	KMSP315IP	15 IP	CM215R ASSY	SSP025016M	15 IP



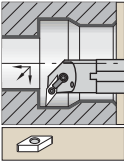

带有内冷的钢刀柄。

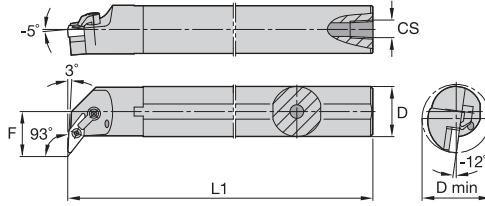

ISO 车削刀具

**■ A-MVUN 93°**

订货号	目录编号	D	D min	F	L1	CS	刀片	垫片	锁销	六角	夹具	夹紧螺钉	六角
右手													
1098128	A25RMVUNR16	25	37,0	22,0	200	1/4-18 NPT	VN..160408	IVSN322	KLM34L	2 mm	CKM31	STCM26	3 mm
1098130	A32SMVUNR16	32	40,0	22,0	250	1/4-18 NPT	VN..160408	IVSN322	KLM34L	2 mm	CKM31	STCM20	3 mm
左手													
1098129	A25RMVUNL16	25	37,0	22,0	200	1/4-18 NPT	VN..160408	IVSN322	KLM34L	2 mm	CKM31	STCM26	3 mm
1098131	A32SMVUNL16	32	40,0	22,0	250	1/4-18 NPT	VN..160408	IVSN322	KLM34L	2 mm	CKM31	STCM20	3 mm

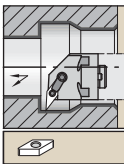

带有内冷。

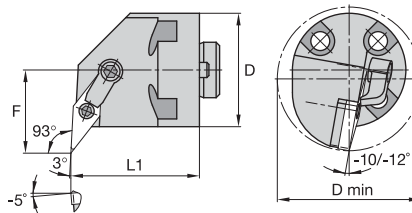
**■ H-MVUN 93°**

订货号	目录编号	D	D min	F	L1	刀片	垫片	锁销	六角	夹具	夹紧螺钉	六角
右手												
3612215	H40MVUNR16	40	50,0	27,0	41	VN..160408	IVSN322	KLM34L	2 mm	CKM22	STCM20	3 mm
3612219	H50MVUNR16	50	63,0	35,0	41	VN..160408	IVSN322	KLM34L	2 mm	CKM22	STCM20	3 mm

● 首选  
○ 备选

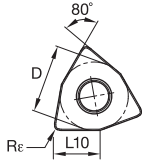
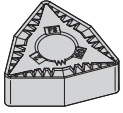

■ WNGG-FS

目录编号	D	L10	Re	KCP05B	KCP05	KCP10B	KCP10	KCP25B	KCP25	KCP30B	KCP30	KCP40B	KCP40	KCK05B	KCK05	KCK15B	KCK15	KCK20B	KCK20	KCM15B	KCM15	KCM25B	KCM25	KCM35B	KCM35	KCPK05	K313	K68	KCU10	KCU25	KC5010	KC5025	KC5410	KT315
WNGG080404FS	12,70	8,69	0,4	-	-	-	-	-	-	-	-	-	-	-	-	-	-	-	-	-	-	-	-	-	-	-	-	-	-	-	-	-	-	-
WNGG080408FS	12,70	8,69	0,8	-	-	-	-	-	-	-	-	-	-	-	-	-	-	-	-	-	-	-	-	-	-	-	-	-	-	-	-	-	-	-

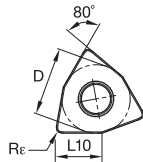
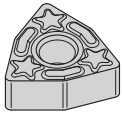

■ WNGG-LF

目录编号	D	L10	Re	KCP05B	KCP05	KCP10B	KCP10	KCP25B	KCP25	KCP30B	KCP30	KCP40B	KCP40	KCK05B	KCK05	KCK15B	KCK15	KCK20B	KCK20	KCM15B	KCM15	KCM25B	KCM25	KCM35B	KCM35	KCPK05	K313	K68	KCU10	KCU25	KC5010	KC5025	KC5410	KT315
WNGG080401LF	12,70	8,69	0,1	-	-	-	-	-	-	-	-	-	-	-	-	-	-	-	-	-	-	-	-	-	-	-	-	-	-	-	-	-	-	-
WNGG080402LF	12,70	8,69	0,2	-	-	-	-	-	-	-	-	-	-	-	-	-	-	-	-	-	-	-	-	-	-	-	-	-	-	-	-	-	-	-
WNGG080404LF	12,70	8,69	0,4	-	-	-	-	-	-	-	-	-	-	-	-	-	-	-	-	-	-	-	-	-	-	-	-	-	-	-	-	-	-	-
WNGG080408LF	12,70	8,69	0,8	-	-	-	-	-	-	-	-	-	-	-	-	-	-	-	-	-	-	-	-	-	-	-	-	-	-	-	-	-	-	-

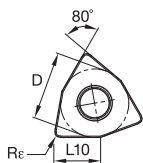
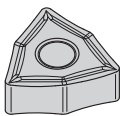

■ WNGP-K

目录编号	D	L10	Re	KCP05B	KCP05	KCP10B	KCP10	KCP25B	KCP25	KCP30B	KCP30	KCP40B	KCP40	KCK05B	KCK05	KCK15B	KCK15	KCK20B	KCK20	KCM15B	KCM15	KCM25B	KCM25	KCM35B	KCM35	KCPK05	K313	K68	KCU10	KCU25	KC5010	KC5025	KC5410	KT315
WNGP080408K	12,70	8,69	0,8	-	-	-	-	-	-	-	-	-	-	-	-	-	-	-	-	-	-	-	-	-	-	-	-	-	-	-	-	-	-	-

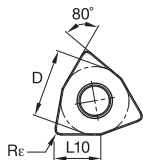
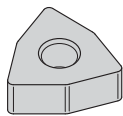
● 首选  
 ○ 备选

**WNMA**

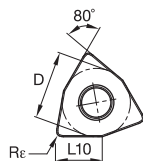
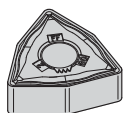
目录编号	D	L10	Re	KCP05B	KCP05	KCP10B	KCP10	KCP25B	KCP25	KCP30B	KCP30	KCP40B	KCP40	KCK05B	KCK05	KCK15B	KCK15	KCK20B	KCK20	KCM15B	KCM15	KCM25B	KCM25	KCM35B	KCM35	KCPK05	K313	K68	KCU10	KCU25	KC5010	KC5025	KC5410	KT315
WNMA060408	9,53	6,52	0,8	-	-	-	-	-	-	-	-	-	-	-	-	-	●	-	-	-	-	-	-	-	-	-	-	-	-	-	-	-	-	-
WNMA060412	9,53	6,52	1,2	-	-	-	-	-	-	-	-	-	-	-	-	-	-	-	-	-	-	-	-	-	-	-	-	-	-	-	-	-	-	-
WNMA080408	12,70	8,69	0,8	-	-	-	-	-	-	-	-	-	-	-	●	-	-	-	-	-	-	-	-	-	-	-	-	-	-	-	-	-	-	-
WNMA080412	12,70	8,69	1,2	-	-	-	-	-	-	-	-	-	-	-	●	-	-	-	-	-	-	-	-	-	-	-	-	-	-	-	-	-	-	-
WNMA080416	12,70	8,69	1,6	-	-	-	-	-	-	-	-	-	-	-	-	-	-	-	●	-	-	-	-	-	-	-	-	-	-	-	-	-	-	-

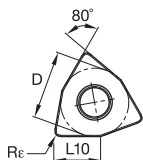
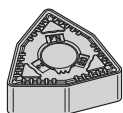

**WNMG-FF**

目录编号	D	L10	Re	KCP05B	KCP05	KCP10B	KCP10	KCP25B	KCP25	KCP30B	KCP30	KCP40B	KCP40	KCK05B	KCK05	KCK15B	KCK15	KCK20B	KCK20	KCM15B	KCM15	KCM25B	KCM25	KCM35B	KCM35	KCPK05	K313	K68	KCU10	KCU25	KC5010	KC5025	KC5410	KT315	
WNMG060404FF	9,53	6,52	0,4	-	-	-	●	-	-	-	-	-	-	-	-	-	-	-	-	-	-	-	-	-	-	-	-	-	●	-	-	-	-	-	
WNMG060408FF	9,53	6,52	0,8	-	-	-	●	-	-	-	-	-	-	-	-	-	-	-	-	-	-	-	-	-	-	-	-	-	-	●	-	-	-	-	-
WNMG080404FF	12,70	8,69	0,4	-	-	-	●	-	-	-	-	-	-	-	-	-	-	-	-	-	-	-	-	-	-	-	-	-	●	-	-	-	-	-	-
WNMG080408FF	12,70	8,69	0,8	-	-	-	●	-	-	-	-	-	-	-	-	-	-	-	-	-	-	-	-	-	-	-	-	-	●	-	-	-	-	-	-

**WNMG-FN**

目录编号	D	L10	Re	KCP05B	KCP05	KCP10B	KCP10	KCP25B	KCP25	KCP30B	KCP30	KCP40B	KCP40	KCK05B	KCK05	KCK15B	KCK15	KCK20B	KCK20	KCM15B	KCM15	KCM25B	KCM25	KCM35B	KCM35	KCPK05	K313	K68	KCU10	KCU25	KC5010	KC5025	KC5410	KT315
WNMG060404FN	9,53	6,52	0,4	-	-	-	●	-	-	-	-	-	-	-	-	-	-	-	-	-	-	-	-	-	-	-	-	-	-	-	-	-	-	●
WNMG060408FN	9,53	6,52	0,8	-	-	-	●	-	-	-	-	-	-	-	-	-	-	-	-	-	-	-	-	-	-	-	-	-	-	-	-	-	-	●
WNMG080404FN	12,70	8,69	0,4	-	●	-	●	-	-	-	-	-	-	-	-	-	-	-	-	-	-	-	-	-	-	-	-	-	-	-	-	-	-	●
WNMG080408FN	12,70	8,69	0,8	-	●	-	●	-	-	-	-	-	-	-	-	-	-	-	-	-	-	-	-	-	-	-	-	-	-	-	-	-	-	●

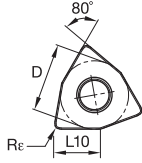
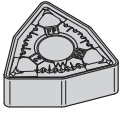
● 首选  
○ 备选



■ WNMG-FP

目录编号	D	L10	Re	KCP05B	KCP05	KCP10B	KCP10	KCP25B	KCP25	KCP30B	KCP30	KCP40B	KCP40	KCK05B	KCK05	KCK15B	KCK15	KCK20B	KCK20	KCM15B	KCM15	KCM25B	KCM25	KCM35B	KCM35	KCPK05	K313	K68	KCU10	KCU25	KC5010	KC5025	KC5410	KT315
WNMG060404FP	9,53	6,52	0,4	-	-	-	-	-	-	-	-	-	-	-	-	-	-	-	-	-	-	-	-	-	-	-	-	-	-	-	-	-	-	-
WNMG060408FP	9,53	6,52	0,8	-	-	-	-	-	-	-	-	-	-	-	-	-	-	-	-	-	-	-	-	-	-	-	-	-	-	-	-	-	-	-
WNMG080404FP	12,70	8,69	0,4	-	-	-	-	-	-	-	-	-	-	-	-	-	-	-	-	-	-	-	-	-	-	-	-	-	-	-	-	-	-	-
WNMG080408FP	12,70	8,69	0,8	-	-	-	-	-	-	-	-	-	-	-	-	-	-	-	-	-	-	-	-	-	-	-	-	-	-	-	-	-	-	-
WNMG080412FP	12,70	8,69	1,2	-	-	-	-	-	-	-	-	-	-	-	-	-	-	-	-	-	-	-	-	-	-	-	-	-	-	-	-	-	-	-

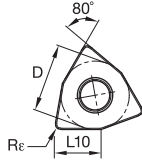
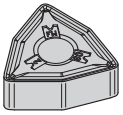

■ WNMG-FW

目录编号	D	L10	Re	KCP05B	KCP05	KCP10B	KCP10	KCP25B	KCP25	KCP30B	KCP30	KCP40B	KCP40	KCK05B	KCK05	KCK15B	KCK15	KCK20B	KCK20	KCM15B	KCM15	KCM25B	KCM25	KCM35B	KCM35	KCPK05	K313	K68	KCU10	KCU25	KC5010	KC5025	KC5410	KT315
WNMG060404FW	9,53	6,52	0,4	●	●	-	-	-	-	-	-	-	-	-	-	-	-	-	-	-	-	-	-	-	-	-	-	-	-	-	-	-	-	-
WNMG060408FW	9,53	6,52	0,8	-	●	-	●	-	-	-	-	-	-	-	-	-	-	-	-	-	-	-	-	-	-	-	-	-	-	-	-	-	-	-
WNMG060412FW	9,53	6,52	1,2	-	-	-	●	-	-	-	-	-	-	-	-	-	-	-	-	-	-	-	-	-	-	-	-	-	-	-	-	-	-	-
WNMG080404FW	12,70	8,69	0,4	-	●	-	●	-	-	-	-	-	-	-	-	-	-	-	-	-	-	-	-	-	-	-	-	-	-	-	-	-	-	-
WNMG080408FW	12,70	8,69	0,8	-	●	-	●	-	-	-	-	-	-	-	-	-	-	-	-	-	-	-	-	-	-	-	-	-	-	-	-	-	-	-
WNMG080412FW	12,70	8,69	1,2	-	●	-	●	-	-	-	-	-	-	-	-	-	-	-	-	-	-	-	-	-	-	-	-	-	-	-	-	-	-	-

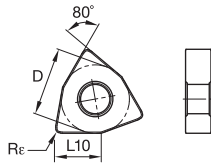
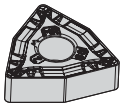

■ WNMG-MG

目录编号	D	L10	Re	KCP05B	KCP05	KCP10B	KCP10	KCP25B	KCP25	KCP30B	KCP30	KCP40B	KCP40	KCK05B	KCK05	KCK15B	KCK15	KCK20B	KCK20	KCM15B	KCM15	KCM25B	KCM25	KCM35B	KCM35	KCPK05	K313	K68	KCU10	KCU25	KC5010	KC5025	KC5410	KT315
WNMG080408MG	12,70	8,69	0,8	-	-	●	-	●	-	-	-	-	-	-	-	-	-	-	-	-	-	-	-	-	-	-	-	-	-	-	-	-	-	-

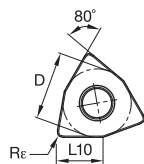
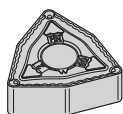
● 首选  
 ○ 备选

**WNMG-MN**

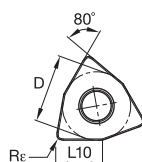
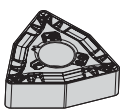
目录编号	D	L10	Re	KCP05B	KCP05	KCP10B	KCP10	KCP25B	KCP25	KCP30B	KCP30	KCP40B	KCP40	KCK05B	KCK05	KCK15B	KCK15	KCK20B	KCK20	KCM15B	KCM15	KCM25B	KCM25	KCM35B	KCM35	KCPK05	K313	K68	KCU10	KCU25	KC5010	KC5025	KC5410	KT315
WNMG060404MN	9,53	6,52	0,4	-	-	-	-	-	-	-	-	-	-	-	-	-	-	-	-	-	-	-	-	-	-	-	-	-	-	-	-	-	-	-
WNMG060408MN	9,53	6,52	0,8	-	-	-	-	●	-	-	-	-	-	-	-	-	-	-	-	-	-	-	-	-	-	-	-	-	-	-	-	-	-	-
WNMG060412MN	9,53	6,52	1,2	-	-	-	-	●	-	-	-	-	-	-	-	-	-	-	-	-	-	-	-	-	-	-	-	-	-	-	-	-	-	-
WNMG080408MN	12,70	8,69	0,8	-	●	-	-	●	-	-	-	-	-	-	-	-	-	-	-	-	-	-	-	-	-	-	-	-	-	-	-	-	-	-
WNMG080412MN	12,70	8,69	1,2	-	-	-	-	●	-	-	-	-	-	-	-	-	-	-	-	-	-	-	-	-	-	-	-	-	-	-	-	-	-	-
WNMG080416MN	12,70	8,69	1,6	-	-	-	-	●	-	-	-	-	-	-	-	-	-	-	-	-	-	-	-	-	-	-	-	-	-	-	-	-	-	-

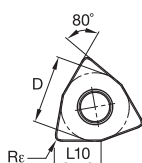
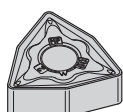

**WNMG-MR**

目录编号	D	L10	Re	KCP05B	KCP05	KCP10B	KCP10	KCP25B	KCP25	KCP30B	KCP30	KCP40B	KCP40	KCK05B	KCK05	KCK15B	KCK15	KCK20B	KCK20	KCM15B	KCM15	KCM25B	KCM25	KCM35B	KCM35	KCPK05	K313	K68	KCU10	KCU25	KC5010	KC5025	KC5410	KT315
WNMG060408MR	9,53	6,52	0,8	-	-	-	-	●	-	-	-	-	-	-	-	-	-	-	-	-	-	-	-	-	-	-	-	-	-	-	-	-	-	-
WNMG080408MR	12,70	8,69	0,8	-	-	●	-	●	-	-	-	-	-	-	-	-	-	-	-	-	-	-	-	-	-	-	-	-	-	-	-	-	-	-
WNMG080412MR	12,70	8,69	1,2	-	-	●	-	●	-	-	-	-	-	-	-	-	-	-	-	-	-	-	-	-	-	-	-	-	-	-	-	-	-	-
WNMG080416MR	12,70	8,69	1,6	-	-	●	-	●	-	-	-	-	-	-	-	-	-	-	-	-	-	-	-	-	-	-	-	-	-	-	-	-	-	-

**WNMG-MP**

目录编号	D	L10	Re	KCP05B	KCP05	KCP10B	KCP10	KCP25B	KCP25	KCP30B	KCP30	KCP40B	KCP40	KCK05B	KCK05	KCK15B	KCK15	KCK20B	KCK20	KCM15B	KCM15	KCM25B	KCM25	KCM35B	KCM35	KCPK05	K313	K68	KCU10	KCU25	KC5010	KC5025	KC5410	KT315
WNMG060404MP	9,53	6,52	0,4	-	-	-	-	-	-	-	-	-	-	-	-	-	-	-	-	-	-	-	-	-	-	-	-	-	-	-	-	-	-	-
WNMG060408MP	9,53	6,52	0,8	-	-	-	-	-	●	-	-	-	-	-	-	-	-	-	-	-	-	-	-	-	-	-	-	-	-	-	-	-	-	-
WNMG060412MP	9,53	6,52	1,2	-	-	-	-	-	-	-	-	-	-	-	-	-	-	-	-	-	-	-	-	-	-	-	-	-	-	-	-	-	-	-
WNMG080408MP	12,70	8,69	0,8	-	-	●	-	●	-	-	-	-	-	-	-	-	-	-	-	-	-	-	-	-	-	-	-	-	-	-	-	-	-	-
WNMG080412MP	12,70	8,69	1,2	-	-	●	-	●	-	-	-	-	-	-	-	-	-	-	-	-	-	-	-	-	-	-	-	-	-	-	-	-	-	-

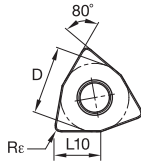
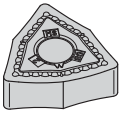
● 首选  
○ 备选



■ WNMG-MS

目录编号	D	L10	Re	KCP05B	KCP05	KCP10B	KCP10	KCP25B	KCP25	KCP30B	KCP30	KCP40B	KCP40	KCK05B	KCK05	KCK15B	KCK15	KCK20B	KCK20	KCM15B	KCM15	KCM25B	KCM25	KCM35B	KCM35	KCPK05	K313	K68	KCU10	KCU25	KC5010	KC5025	KC5410	KT315
WNMG060408MS	9,53	6,52	0,8	-	-	-	-	-	-	-	-	-	-	-	-	-	-	-	-	-	-	-	-	-	-	-	-	-	-	-	-	-	-	-
WNMG080401MS	12,70	8,69	0,1	-	-	-	-	-	-	-	-	-	-	-	-	-	-	-	-	-	-	-	-	-	-	-	-	-	-	-	-	-	-	-
WNMG080402MS	12,70	8,69	0,2	-	-	-	-	-	-	-	-	-	-	-	-	-	-	-	-	-	-	-	-	-	-	-	-	-	-	-	-	-	-	-
WNMG080404MS	12,70	8,69	0,4	-	-	-	-	-	-	-	-	-	-	-	-	-	-	-	-	-	-	-	-	-	-	-	-	-	-	-	-	-	-	-
WNMG080408MS	12,70	8,69	0,8	-	-	-	-	-	-	-	-	-	-	-	-	-	-	-	-	-	-	-	-	-	-	-	-	-	-	-	-	-	-	-

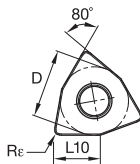
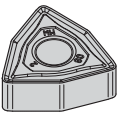

■ WNMG-MW

目录编号	D	L10	Re	KCP05B	KCP05	KCP10B	KCP10	KCP25B	KCP25	KCP30B	KCP30	KCP40B	KCP40	KCK05B	KCK05	KCK15B	KCK15	KCK20B	KCK20	KCM15B	KCM15	KCM25B	KCM25	KCM35B	KCM35	KCPK05	K313	K68	KCU10	KCU25	KC5010	KC5025	KC5410	KT315
WNMG060408MW	9,53	6,52	0,8	-	-	-	-	-	-	-	-	-	-	-	-	-	-	-	-	-	-	-	-	-	-	-	-	-	-	-	-	-	-	-
WNMG080408MW	12,70	8,69	0,8	-	-	●	●	●	●	-	-	-	-	-	-	-	-	-	-	-	-	-	-	-	-	-	-	-	-	-	-	-	-	-
WNMG080412MW	12,70	8,69	1,2	-	●	●	●	●	●	-	-	-	-	-	-	-	-	-	-	-	●	-	-	-	-	-	-	-	-	-	-	-	-	-

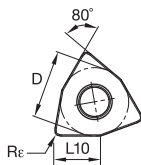
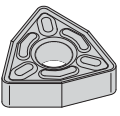

■ WNMG-P

目录编号	D	L10	Re	KCP05B	KCP05	KCP10B	KCP10	KCP25B	KCP25	KCP30B	KCP30	KCP40B	KCP40	KCK05B	KCK05	KCK15B	KCK15	KCK20B	KCK20	KCM15B	KCM15	KCM25B	KCM25	KCM35B	KCM35	KCPK05	K313	K68	KCU10	KCU25	KC5010	KC5025	KC5410	KT315
WNMG080404P	12,70	8,69	0,4	-	-	-	-	-	-	-	-	-	-	-	-	-	-	-	-	-	-	-	-	-	-	-	-	-	-	-	-	-	-	-
WNMG080408P	12,70	8,69	0,8	-	-	-	-	-	-	-	-	-	-	-	-	-	-	-	-	●	-	-	-	-	-	-	-	-	-	-	-	-	-	-

● 首选  
○ 备选

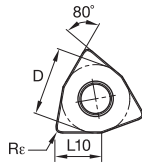
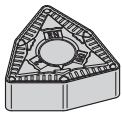

■ WNMG-RN

目录编号	D	L10	Re	KCP05B	KCP05	KCP10B	KCP10	KCP25B	KCP25	KCP30B	KCP30	KCP40B	KCP40	KCK05B	KCK05	KCK15B	KCK15	KCK20B	KCK20	KCM15B	KCM15	KCM25B	KCM25	KCM35B	KCM35	KCPK05	K313	K68	KCU10	KCU25	KC5010	KC5025	KC5410	KT315
WNMG060408RN	9,53	6,52	0,8	-	-	●	-	●	●	-	-	-	-	-	-	-	-	-	-	-	-	-	-	-	-	-	-	-	-	-	-	-	-	-
WNMG060412RN	9,53	6,52	1,2	-	-	●	-	●	●	-	-	-	-	-	-	-	-	-	-	-	-	-	-	-	-	-	-	-	-	-	-	-	-	-
WNMG080408RN	12,70	8,69	0,8	-	-	●	●	●	●	●	-	-	-	-	-	-	-	-	-	-	-	-	-	-	-	-	-	-	-	-	-	-	-	-
WNMG080412RN	12,70	8,69	1,2	-	●	●	●	●	●	●	-	-	-	-	-	-	-	-	-	-	-	-	-	-	-	●	-	-	-	-	-	-	-	-
WNMG080416RN	12,70	8,69	1,6	-	-	●	●	●	●	-	-	-	-	-	-	-	-	-	-	-	-	-	-	-	-	-	-	-	-	-	-	-	-	-

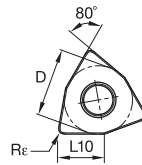
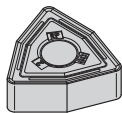

■ WNMG-RP

目录编号	D	L10	Re	KCP05B	KCP05	KCP10B	KCP10	KCP25B	KCP25	KCP30B	KCP30	KCP40B	KCP40	KCK05B	KCK05	KCK15B	KCK15	KCK20B	KCK20	KCM15B	KCM15	KCM25B	KCM25	KCM35B	KCM35	KCPK05	K313	K68	KCU10	KCU25	KC5010	KC5025	KC5410	KT315
WNMG060408RP	9,53	6,52	0,8	-	-	●	●	●	●	-	-	-	-	-	-	-	-	-	-	-	●	-	●	-	-	-	-	-	●	-	-	-	-	-
WNMG060412RP	9,53	6,52	1,2	-	-	●	●	●	●	-	-	-	-	-	-	-	-	-	-	-	-	-	-	-	-	-	-	-	-	-	-	-	-	-
WNMG080408RP	12,70	8,69	0,8	-	●	●	●	●	●	●	-	-	-	-	-	-	-	-	-	-	-	-	-	-	-	-	-	-	-	-	-	-	-	-
WNMG080412RP	12,70	8,69	1,2	-	●	●	●	●	●	●	-	-	-	-	-	-	-	-	-	-	-	-	-	-	-	-	-	-	-	-	-	-	-	-
WNMG080416RP	12,70	8,69	1,6	-	-	●	●	●	●	-	-	-	-	-	-	-	-	-	-	-	-	-	-	-	-	-	-	-	-	-	-	-	-	-





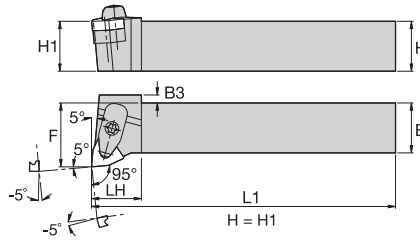
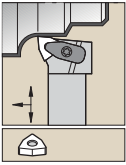

■ DWLN-KC 95°



订货号	目录编号	H	B	F	L1	LH	B3	刀片	垫片	垫片螺钉	Torx Plus	夹具装配件	Torx Plus	槽销	可选择锁定销
<b>右手</b>															
2439476	DWLN2020K06KC04	20	20	25,0	125	31,0	—	WN..060408	IWSN322	KMSP315IP	15 IP	CM234R ASSY	15 IP	SSP025016M	KLM34L9IP
2439471	DWLN2020K08KC04	20	20	25,0	125	33,0	—	WN..080408	IWSN433	KMSP415IP	15 IP	CM234R ASSY	15 IP	SSP025016M	KLM4615IP
2273451	DWLN2525M06KC04	25	25	32,0	150	25,0	—	WN..060408	IWSN322	KMSP315IP	15 IP	CM234R ASSY	15 IP	SSP025016M	KLM34L9IP
1908860	DWLN2525M08KC04	25	25	32,0	150	25,0	4,0	WN..080408	IWSN433	KMSP415IP	15 IP	CM234R ASSY	15 IP	SSP025016M	KLM4615IP
1908862	DWLN3232P08KC04	32	32	40,0	170	25,0	—	WN..080408	IWSN433	KMSP415IP	15 IP	CM234R ASSY	15 IP	SSP025016M	KLM4615IP
<b>左手</b>															
2439470	DWLN2020K06KC04	20	20	25,0	125	31,0	—	WN..060408	IWSN322	KMSP315IP	15 IP	CM234R ASSY	15 IP	SSP025016M	KLM34L9IP
2439472	DWLN2020K08KC04	20	20	25,0	125	33,0	—	WN..080408	IWSN433	KMSP415IP	15 IP	CM234R ASSY	15 IP	SSP025016M	KLM4615IP
2273455	DWLN2525M06KC04	25	25	32,0	150	25,0	—	WN..060408	IWSN322	KMSP315IP	15 IP	CM234R ASSY	15 IP	SSP025016M	KLM34L9IP
1908861	DWLN2525M08KC04	25	25	32,0	150	25,0	4,0	WN..080408	IWSN433	KMSP415IP	15 IP	CM234R ASSY	15 IP	SSP025016M	KLM4615IP
1908893	DWLN3232P08KC04	32	32	40,0	170	25,0	—	WN..080408	IWSN433	KMSP415IP	15 IP	CM234R ASSY	15 IP	SSP025016M	KLM4615IP

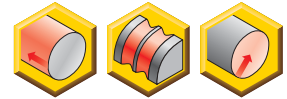
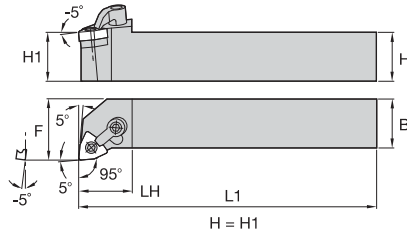
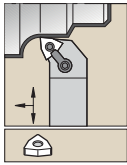

■ MWLN 95°



订货号	目录编号	H	B	F	L1	LH	刀片	垫片	锁销	六角	夹具	夹紧螺钉	六角
右手													
1101293	MWLN2020K06	20	20	25,0	125	25,0	WN..060408	IWSN322	KLM34L	2 mm	CKM6	STCM5	2.5 mm
1101355	MWLN2525M06	25	25	32,0	150	25,0	WN..060408	IWSN322	KLM34L	2 mm	CKM6	STCM5	2.5 mm
3612259	MWLN3232P08	32	32	40,0	170	32,0	WNMA080408	IWSN433	KLM46	2.5 mm	CKM7	STCM5	2.5 mm
左手													
1101292	MWLN2020K06	20	20	25,0	125	25,0	WN..060408	IWSN322	KLM34L	2 mm	CKM6	STCM5	2.5 mm
1101354	MWLN2525M06	25	25	32,0	150	25,0	WN..060408	IWSN322	KLM34L	2 mm	CKM6	STCM5	2.5 mm
3612260	MWLN3232P08	32	32	40,0	170	32,0	WNMA080408	IWSN433	KLM46	2.5 mm	CKM7	STCM5	2.5 mm

**Wedgelock™ 刀柄 • Wedgelock 刀片**

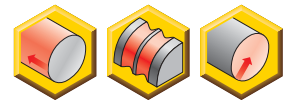
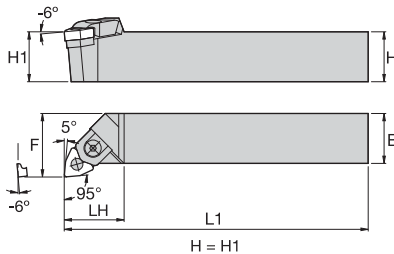
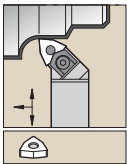

■ MWLN 95°

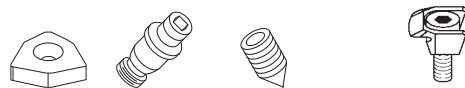

订货号	目录编号	H	B	F	L1	LH	刀片	垫片	锁销	设置螺钉	Torx	夹具及配件	六角
右手													
1244924	MWLN2020K08H4	20	20	25,0	125	32,0	WN..080408	512.131	513.132	192.636	T15	551.131	3 mm
1192355	MWLN2525M08H4	25	25	32,0	150	36,0	WN..080408	512.131	513.132	192.636	T15	551.131	3 mm
1244925	MWLN3225P08H4	32	25	32,0	170	36,0	WN..080408	512.131	513.132	192.636	T15	551.131	3 mm
左手													
1244921	MWLN2020K08H4	20	20	25,0	125	32,0	WN..080408	512.131	513.132	192.636	T15	551.131	3 mm
1244922	MWLN2525M08H4	25	25	32,0	150	36,0	WN..080408	512.131	513.132	192.636	T15	551.131	3 mm
1244923	MWLN3225P08H4	32	25	32,0	170	36,0	WN..080408	512.131	513.132	192.636	T15	551.131	3 mm

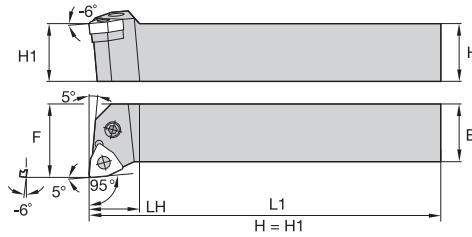
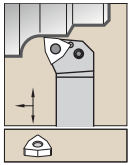
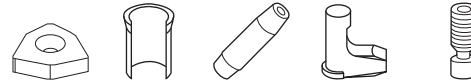
**■ PWLN 95°**

订货号	目录编号	H	B	F	L1	LH	刀片	垫片	垫片销	冲头	杠杆	杠杆螺钉	Torx Plus
<b>右手</b>													
1244771	PWLN1616H06	16	16	20,0	100	14,0	WN..060404	512.134	513.018	515.018	511.018	514.118	10 IP
1192397	PWLN2020K06	20	20	25,0	125	14,0	WN..060404	512.134	513.018	515.018	511.018	514.118	10 IP
1192398	PWLN2020K08	20	20	25,0	125	20,0	WN..080408	512.135	513.023	515.018	511.023	514.123	15 IP
1192399	PWLN2525M08	25	25	32,0	150	26,0	WN..080408	512.135	513.023	515.018	511.023	514.123	15 IP
1244772	PWLN3225P08	32	25	32,0	170	26,0	WN..080408	512.135	513.023	515.018	511.023	514.123	15 IP
<b>左手</b>													
1192396	PWLN1616H06	16	16	20,0	100	14,0	WN..060404	512.134	513.018	515.018	511.018	514.118	10 IP
1244767	PWLN2020K06	20	20	25,0	125	14,0	WN..060404	512.134	513.018	515.018	511.018	514.118	10 IP
1244768	PWLN2020K08	20	20	25,0	125	20,0	WN..080408	512.135	513.023	515.018	511.023	514.123	15 IP
1244769	PWLN2525M08	25	25	32,0	150	26,0	WN..080408	512.135	513.023	515.018	511.023	514.123	15 IP
1244770	PWLN3225P08	32	25	32,0	170	26,0	WN..080408	512.135	513.023	515.018	511.023	514.123	15 IP

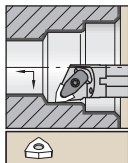
**Kenclamp™ 镗杆**

带有内冷的钢刀柄。

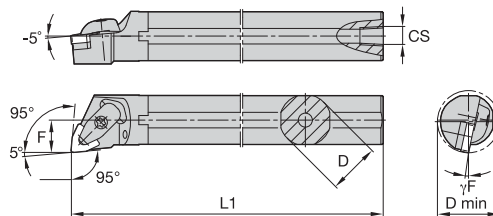
**■ A-DWLN-KC 95°**

订货号	目录编号	D	D min	F	L1	CS	yF°	刀片	垫片	垫片螺钉	Torx Plus	夹具装配件	槽销	Torx Plus
<b>右手</b>														
2441921	A25RDWLN06KC04	25	32,0	17,0	200	1/4-18 NPT	-14,0	WN..060408	—	—	—	CM234R ASSY	SSP025016M	15 IP
2441923	A25RDWLN08KC04	25	32,0	17,0	200	1/4-18 NPT	-12,0	WN..080408	—	—	—	CM234R ASSY	SSP025016M	15 IP
2441925	A32SDWLN08KC04	32	40,0	22,0	250	1/4-18 NPT	-14,0	WN..080408	IWSN433	KMSP415IP	15 IP	CM234R ASSY	SSP025016M	15 IP
2441927	A40TDWLN08KC04	40	50,0	27,0	300	1/4-18 NPT	-14,0	WN..080408	IWSN433	KMSP415IP	15 IP	CM234R ASSY	SSP025016M	15 IP
<b>左手</b>														
2441922	A25RDWLN06KC04	25	32,0	17,0	200	1/4-18 NPT	-14,0	WN..060408	—	—	—	CM234R ASSY	SSP025016M	15 IP
2441924	A25RDWLN08KC04	25	32,0	17,0	200	1/4-18 NPT	-12,0	WN..080408	—	—	—	CM234R ASSY	SSP025016M	15 IP
2441926	A32SDWLN08KC04	32	40,0	22,0	250	1/4-18 NPT	-14,0	WN..080408	IWSN433	KMSP415IP	15 IP	CM234R ASSY	SSP025016M	15 IP



带内冷功能的钢质刀柄。

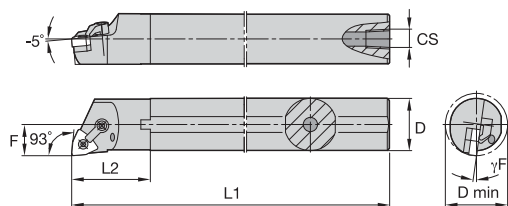

■ A-MWLN 95°



订货号	目录编号	D	D min	F	L1	LH	CS	γF°	刀片	垫片	锁销	六角	夹具	夹紧螺钉	六角
右手															
1098771	A25RMWLN06	25	32,0	17,0	200	—	1/4-18 NPT	-12.0	WN..060408	—	KLM33L	2 mm	CKM6	STCM5	2.5 mm
1098773	A25RMWLN08	25	32,0	17,0	200	39,0	1/4-18 NPT	-12.0	WN..080408	—	KLM43	2 mm	CKM20	STCM11	3 mm
1098772	A32SMWLN06	32	40,0	22,0	250	—	1/4-18 NPT	-10.0	WN..060408	IWSN322	KLM34L	2 mm	CKM6	STCM5	2.5 mm
1098774	A32SMWLN08	32	40,0	22,0	250	39,7	1/4-18 NPT	-14.0	WN..080408	IWSN433	KLM46	2.5 mm	CKM20	STCM20	3 mm
1098775	A40TMWLN08	40	50,0	27,0	300	41,6	1/4-18 NPT	-12.0	WN..080408	IWSN433	KLM46	2.5 mm	CKM20	STCM20	3 mm
左手															
1098783	A25RMWLN08	25	32,0	17,0	200	39,0	1/4-18 NPT	-12.0	WN..080408	—	KLM43	2 mm	CKM20	STCM11	3 mm
1098782	A32SMWLN06	32	40,0	22,0	250	—	1/4-18 NPT	-10.0	WN..060408	IWSN322	KLM34L	2 mm	CKM6	STCM5	2.5 mm
1098784	A32SMWLN08	32	40,0	22,0	251	39,7	1/4-18 NPT	-14.0	WN..080408	IWSN433	KLM46	2.5 mm	CKM20	STCM20	3 mm
1098785	A40TMWLN08	40	50,0	27,0	300	41,6	1/4-18 NPT	-12.0	WN..080408	IWSN433	KLM46	2.5 mm	CKM20	STCM20	3 mm

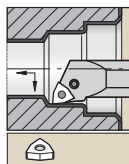

带内冷功能的钢质刀柄。

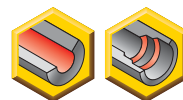
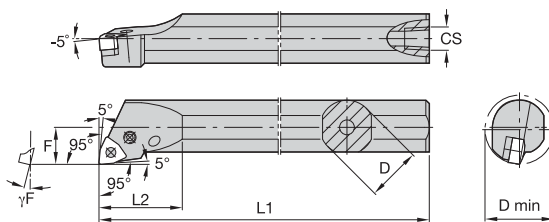

## ■ A-PWLN 95°



订货号	目录编号	D	D min	F	L1	L2	CS	$\gamma_F^\circ$	刀片	垫片	垫片销	销	杠杆	杠杆螺钉	Torx Plus
右手															
1244113	A16RPWLN06	16	27,0	11,0	200	32	1/8-27 NPT	-12,0	WN..060404	—	—	—	511.030	514.112	—
1244115	A20SPWLN06	20	25,0	13,0	250	—	1/8-27 NPT	-14,0	WN..060408	—	—	—	511.030	514.112	8 IP
1194440	A25RPWLN08	25	32,0	17,0	200	—	1/4-18 NPT	-12,0	WN..080408	512.135	513.023	515.018	511.023	514.123	15 IP
1244118	A32SPWLN08	32	40,0	22,0	250	50	1/4-18 NPT	-10,0	WN..080408	512.135	513.023	515.018	511.023	514.123	—
1244120	A40TPWLN08	40	50,0	27,0	300	54	1/4-18 NPT	-8,0	WN..080408	512.135	513.023	515.018	511.023	514.123	—
左手															
1191396	A16RPWLN06	16	27,0	11,0	200	32	1/8-27 NPT	-12,0	WN..060404	—	—	—	511.030	514.112	—
1244114	A20SPWLN06	20	25,0	13,0	250	—	1/8-27 NPT	-14,0	WN..060408	—	—	—	511.030	514.112	8 IP
1244116	A25RPWLN08	25	32,0	17,0	200	—	1/4-18 NPT	-12,0	WN..080408	512.135	513.023	515.018	511.023	514.123	15 IP
1244117	A32SPWLN08	32	40,0	22,0	250	50	1/4-18 NPT	-10,0	WN..080408	512.135	513.023	515.018	511.023	514.123	—
1244119	A40TPWLN08	40	50,0	27,0	300	54	1/4-18 NPT	-8,0	WN..080408	512.135	513.023	515.018	511.023	514.123	—

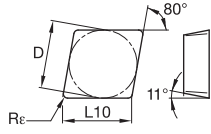
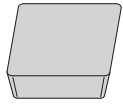

■ CPGN

目录编号	D	L10	Rε	KCP25B	KCK15B	KCK15	K313	K68	KCS10	KCU10	KC5010
CPGN120304	12,70	12,90	0,4	-	-	-	●	●	-	-	-
CPGN120308	12,70	12,90	0,8	-	-	●	●	●	-	-	-

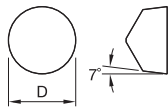
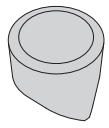

■ RCGV

目录编号	D	L10	Rε	KCP25B	KCK15B	KCK15	K313	K68	KCS10	KCU10	KC5010
RCGV060400	6,35	-	-	-	-	-	-	-	-	-	-
RCGV090700	9,53	-	-	-	-	-	-	-	-	●	●
RCGV120700	12,70	-	-	-	-	●	-	-	-	-	●

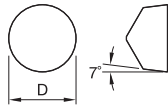
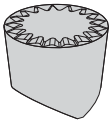

■ RCGV-MP

目录编号	D	L10	Rε	KCP25B	KCK15B	KCK15	K313	K68	KCS10	KCU10	KC5010
RCGX060400MP	6,35	-	-	-	-	-	-	-	-	-	-
RCGX120700MP	12,70	-	-	-	-	-	-	-	●	-	-

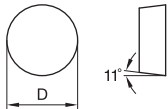
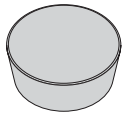

■ RPGN

目录编号	D	L10	Rε	KCP25B	KCK15B	KCK15	K313	K68	KCS10	KCU10	KC5010
RPGN120300	12,70	-	-	-	-	-	●	-	-	-	-

● 首选  
○ 备选

P	●	○	○	○	○	○	○	○	○	○	○
M	○	○	○	○	○	○	○	○	○	○	○
K	○	○	○	○	○	○	○	○	○	○	○
N	○	○	○	○	○	○	○	○	○	○	○
S	○	○	○	○	○	○	○	○	○	○	○
H	○	○	○	○	○	○	○	○	○	○	○



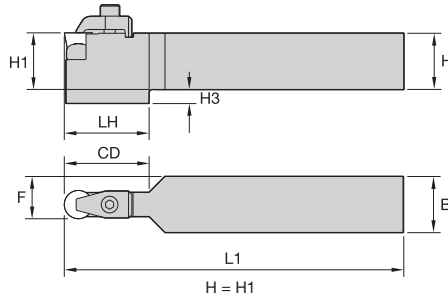
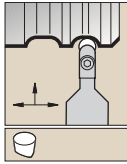

■ CRDP

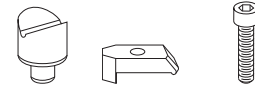

订货号	目录编号	H	B	F	L1	LH	H3	CD	刀片	套	夹具	夹紧螺钉	六角
3642247	CRDPN2525M06V	25	25	12,5	151	—	—	19,0	RPGX060400E	NST1	CM214	MS1321	2.5 mm
3642249	CRDPN3232P09V	32	32	16,0	171	—	—	29,0	RPGX090700E	NST2	CM219	CS412	3.5 mm
3642248	CRDPN2525M09V	25	25	12,5	151	—	—	29,0	RPGX090700E	NST2	CM219	CS412	3.5 mm
3642251	CRDPN3232P12V	32	32	16,0	171	—	—	38,0	RPGX120700E	NST3	CM216	CS412	3.5 mm
3642252	CRDPN3232P15V	32	32	16,0	171	38,1	6,4	38,0	RPGX151000	NST4	CM217	MS1294	6 mm

注: CRDP 刀柄可以使用 RPGX 和 RCGX 类型刀片。

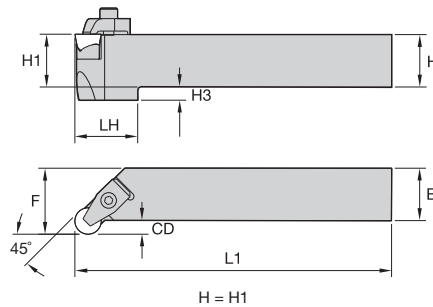
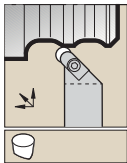

■ CRGP

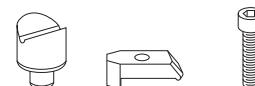

订货号	目录编号	H	B	F	L1	CD	刀片	套	夹具	夹紧螺钉	六角	
右手												
3642276	CRGPR2525M06V	25	25	32,0	151	7,0	RPGX060400E	NST1	CM214	MS1321	2.5 mm	
3642280	CRGPR3232P09V	32	32	40,0	171	8,0	RPGX090700E	NST2	CM219	CS412	3.5 mm	
左手												
3642277	CRGPL2525M06V	25	25	32,0	151	7,0	RPGX060400E	NST1	CM214	MS1321	2.5 mm	
3642281	CRGPL3232P09V	32	32	40,0	171	8,0	RPGX090700E	NST2	CM219	CS412	3.5 mm	

注: CRGP 刀柄可以使用 RPGX 和 RCGX 类型刀片。



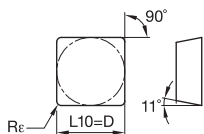
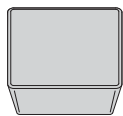

 ● 首选  
 ○ 备选

P	●	○	○	○	○	○	○	○	○	○
M	○	○	○	○	○	○	○	○	○	○
K	○	○	○	○	○	○	○	○	○	○
N	○	○	○	○	○	○	○	○	○	○
S	○	○	○	○	○	○	○	○	○	○
H	○	○	○	○	○	○	○	○	○	○

**■ SPGN**

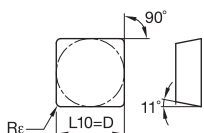
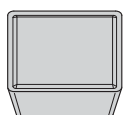
目录编号	D	L10	Rε	KCP25B	KCK15B	KCK15	K313	K68	KCS10	KCU10	KC5010
SPGN090304	9,53	9,53	0,4	-	-	-	-	-	-	-	-
SPGN090308	9,53	9,53	0,8	-	-	●	-	-	-	-	●
SPGN120304	12,70	12,70	0,4	-	-	-	-	-	-	-	-
SPGN120308	12,70	12,70	0,8	-	-	●	●	-	-	-	●
SPGN120312	12,70	12,70	1,2	-	-	-	-	●	-	-	-
SPGN120412	12,70	12,70	1,2	-	-	-	-	-	-	●	-
SPGN120316	12,70	12,70	1,6	-	-	-	-	-	-	-	●
SPGN190408	19,05	19,05	0,8	-	-	-	●	-	-	-	-
SPGN190412	19,05	19,05	1,2	-	-	●	-	-	-	●	-

**■ SPGR-K**

目录编号	D	L10	Rε	KCP25B	KCK15B	KCK15	K313	K68	KCS10	KCU10	KC5010
SPGR090308K	9,53	9,53	0,8	-	-	-	-	-	-	●	●
SPGR120308K	12,70	12,70	0,8	●	-	-	-	-	-	-	-

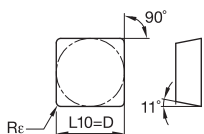
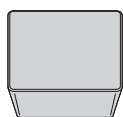
**■ SPUN**

目录编号	D	L10	Rε	KCP25B	KCK15B	KCK15	K313	K68	KCS10	KCU10	KC5010
SPUN120304	12,70	12,70	0,4	●	-	-	-	-	-	-	-
SPUN120308	12,70	12,70	0,8	●	-	-	-	●	-	-	-
SPUN120312	12,70	12,70	1,2	●	-	-	-	-	-	-	-

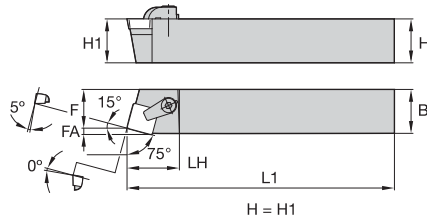
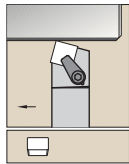

■ CSBP 75°



订货号	目录编号	H	B	F	L1	LH	FA	刀片	垫片	垫片螺钉	六角	夹具	夹紧螺钉	六角
右手														
1097750	CSBPR2020K12	20	20	17,0	125	30,0	3,1	SP..120308	SM840	MS111	2 mm	CKM10	STCM8	4 mm

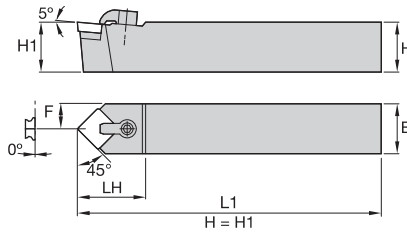
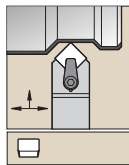

■ CSDP 45°



订货号	目录编号	H	B	F	L1	LH	FA	刀片	垫片	垫片螺钉	六角	夹具	夹紧螺钉	六角
1097754	CSDPN2020K12	20	20	10,0	125	32,0		SP..120308	SM840	MS111	2 mm	CKM10	STCM8	4 mm
1097755	CSDPN2525M12	25	25	12,5	150	32,0		SP..120308	SM840	MS111	2 mm	CKM9	STCM4	4 mm

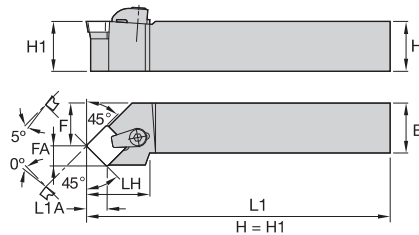
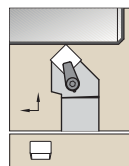

■ CSSP 45°



订货号	目录编号	H	B	F	L1	LH	FA	L1A	刀片	垫片	垫片螺钉	六角	夹具	夹紧螺钉	六角
右手															
1244605	CSSPR2020K12	20	20	25,0	125	32,0	8,7	8,3	SP..120308	SM840	MS111	2 mm	CKM10	STCM8	4 mm
1244606	CSSPR2525M12	25	25	32,0	150	32,0	8,7	8,3	SP..120308	SM840	MS111	2 mm	CKM9	STCM4	4 mm
左手															
1244604	CSSPL2525M12	25	25	32,0	150	32,0	8,7	8,3	SP..120308	SM840	MS111	2 mm	CKM9	STCM4	4 mm

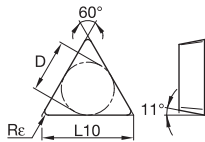
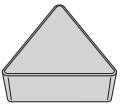

● 首选  
○ 备选

P	●	○	○	●	●	●	●	●	●	●
M	●	○	○	●	●	●	●	●	●	●
K	○	●	●	●	●	●	●	●	●	●
N	○	○	○	○	○	○	○	○	○	○
S	○	○	○	○	○	○	○	○	○	○
H	○	○	○	○	○	○	○	○	○	○

■ TPGN/TPG

目录编号	D	L10	Rε	KCP25B	KCK15B	KCK15	K313	K68	KCS10	KCU10	KC5010
TPGN110304	6,35	11,00	0,4	-	-	-	-	-	-	-	-
TPGN110308	6,35	11,00	0,8	-	-	-	-	-	-	-	-
TPGN160302	9,53	16,50	0,2	-	-	-	-	-	-	-	-
TPGN160304	9,53	16,50	0,4	-	-	-	-	-	-	-	-
TPGN160308	9,53	16,50	0,8	-	-	-	-	-	-	-	-
TPGN160312	9,53	16,50	1,2	-	-	-	-	-	-	-	-
TPGN160316	9,53	16,50	1,6	-	-	-	-	-	-	-	-
TPGN220404	12,70	22,00	0,4	-	-	-	-	-	-	-	-
TPGN220408	12,70	22,00	0,8	●	-	-	-	-	-	-	-
TPGN220412	12,70	22,00	1,2	-	-	-	-	-	-	-	-
TPGN220416	12,70	22,00	1,6	-	-	-	-	●	-	-	-

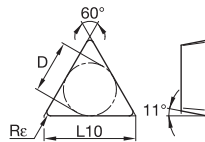
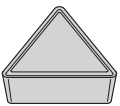

■ TPGR-K

目录编号	D	L10	Rε	KCP25B	KCK15B	KCK15	K313	K68	KCS10	KCU10	KC5010
TPGR110304K	6,35	11,00	0,4	-	-	-	-	-	-	-	-
TPGR110308K	6,35	11,00	0,8	-	-	-	-	-	-	-	-
TPGR160304K	9,53	16,50	0,4	-	-	-	-	-	-	-	-
TPGR160308K	9,53	16,50	0,8	●	-	-	-	-	-	-	-
TPGR220404K	12,70	22,00	0,4	-	-	-	-	-	-	-	-
TPGR220408K	12,70	22,00	0,8	-	-	-	-	-	-	-	-

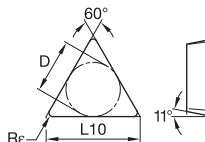
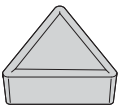

■ TPMR

目录编号	D	L10	Rε	KCP25B	KCK15B	KCK15	K313	K68	KCS10	KCU10	KC5010
TPMR110304	6,35	11,00	0,4	●	●	-	-	-	-	-	-
TPMR110308	6,35	11,00	0,8	●	●	-	-	-	-	-	-
TPMR160304	9,53	16,50	0,4	●	●	-	-	-	-	-	-
TPMR160308	9,53	16,50	0,8	●	●	-	-	-	-	-	-
TPMR220408	12,70	22,00	0,8	●	-	-	-	-	-	-	-

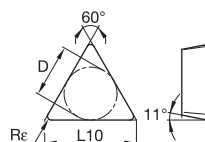
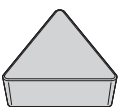

■ TPUN

目录编号	D	L10	Rε	KCP25B	KCK15B	KCK15	K313	K68	KCS10	KCU10	KC5010
TPUN110304	6,35	11,00	0,4	-	●	-	-	-	-	-	-
TPUN110308	6,35	11,00	0,8	-	●	-	-	-	-	-	-
TPUN160304	9,53	16,50	0,4	●	●	-	-	-	-	-	-
TPUN160308	9,53	16,50	0,8	●	●	-	-	-	-	-	-
TPUN220408	12,70	22,00	0,8	●	-	-	-	-	-	-	-
TPUN220412	12,70	22,00	1,2	-	-	-	-	-	-	-	-

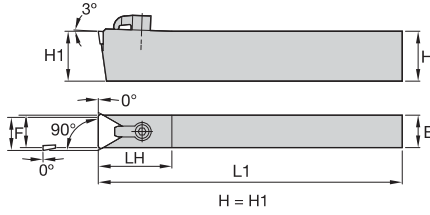
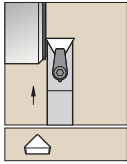

■ CTCP 90°



订货号	目录编号	H	B	F	L1	LH	刀片	垫片	垫片螺钉	六角	夹具	夹紧螺钉	六角
1097775	CTCPN2510M11	25	10	10,0	150	26,0	TP..110304	SM819	MS960	—	CKM7	STCM5	2.5 mm
1097776	CTCPN2514M16	25	14	14,4	150	28,0	TP..160308	SM841	MS111	2 mm	CKM13	STCM4	4 mm
1097781	CTCPN2518M22	25	18	19,2	150	41,0	TP..220408	SM837	MS125	2.5 mm	CKM13	STCM4	4 mm
1097778	CTCPN2520M22	25	20	20,2	150	41,0	TP..220408	SM837	MS125	2.5 mm	CKM13	STCM4	4 mm

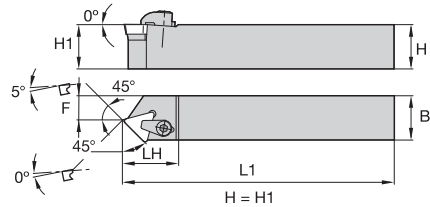
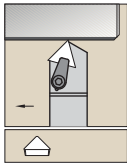

■ CTDTP 45°

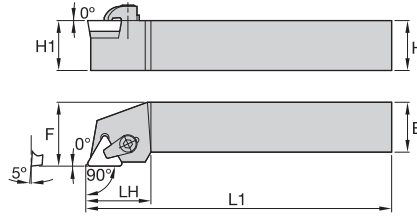
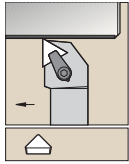

订货号	目录编号	H	B	F	L1	LH	刀片	垫片	垫片螺钉	夹具	夹紧螺钉	六角
1244613	CTDPR1212F11	12	12	6,0	80	22,0	TP..110304	SM819	MS960	CKM19	STCM9	2.5 mm

**CTGP 90°**

订货号	目录编号	H	B	F	L1	LH	刀片	垫片	垫片螺钉	六角	夹具	夹紧螺钉	六角
<b>右手</b>													
1097762	CTGPR1212F11	12	12	16,0	80	20,0	TP..110304	SM819	MS960	—	CKM19	STCM9	2.5 mm
1097763	CTGPR1616H11	16	16	20,0	100	20,0	TP..110304	SM819	MS960	—	CKM19	STCM9	2.5 mm
1244595	CTGPR2020K11	20	20	25,0	125	20,0	TP..110304	SM819	MS960	—	CKM19	STCM9	2.5 mm
1097764	CTGPR2020K16	20	20	25,0	125	26,0	TP..160308	SM841	MS111	2 mm	CKM10	STCM8	4 mm
1097765	CTGPR2525M16	25	25	32,0	150	26,0	TP..160308	SM841	MS111	2 mm	CKM9	STCM4	4 mm
<b>左手</b>													
1097916	CTGPL1212F11	12	12	16,0	80	20,0	TP..110304	SM819	MS960	—	CKM19	STCM9	2.5 mm
1097918	CTGPL2020K16	20	20	25,0	125	26,0	TP..160308	SM841	MS111	2 mm	CKM10	STCM8	4 mm
1097919	CTGPL2525M16	25	25	32,0	150	26,0	TP..160308	SM841	MS111	2 mm	CKM9	STCM4	4 mm

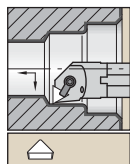

带内冷功能的钢质刀柄。

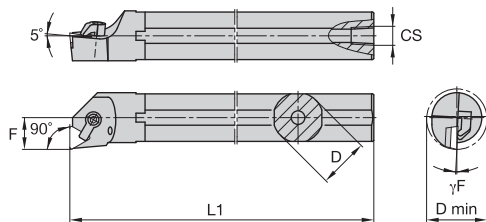

■ A-CTFP 90°



订货号	目录编号	D	D min	F	L1	CS	γF°	刀片	垫片	垫片螺钉	六角	夹具	夹紧螺钉	六角
右手														
1886492	A16RCTFPR11	16	20,0	11,0	200	1/8-27 NPT	-4.0	TP..110304	—	—	—	CKM19	STCM9	2.5 mm
1098051	A20QCTFPR11	20	25,0	13,0	180	1/8-27 NPT	0.0	TP..110304	SM815	MS961	—	CKM19	STCM9	2.5 mm
1098053	A25RCTFPR16	25	32,0	17,0	200	1/4-18 NPT	-3.0	TP..160308	SM841	MS110	2 mm	CKM10	STCM8	4 mm
1098055	A32SCTFPR16	32	40,0	22,0	250	1/4-18 NPT	-3.0	TP..160308	SM841	MS110	2 mm	CKM10	STCM8	4 mm
1886494	A40VCTFPR16	40	48,0	27,0	400	1/4-18 NPT	-3.0	TP..160308	SM841	MS110	2 mm	CKM10	STCM8	4 mm
左手														
1098054	A25RCTFPL16	25	32,0	17,0	200	1/4-18 NPT	-3.0	TP..160308	SM841	MS110	2 mm	CKM10	STCM8	4 mm
1098056	A32SCTFPL16	32	40,0	22,0	250	1/4-18 NPT	-3.0	TP..160308	SM841	MS110	2 mm	CKM10	STCM8	4 mm

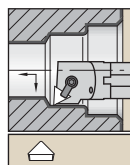

带内冷功能的钢质刀柄。

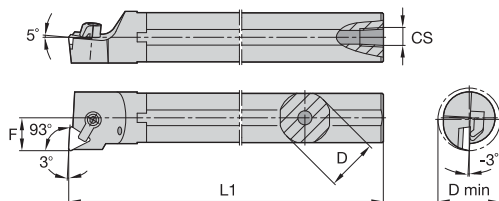

■ A-CTUP 93°

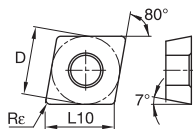
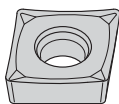

订货号	目录编号	D	D min	F	L1	CS	刀片	垫片	垫片螺钉	夹具	夹紧螺钉	六角
右手												
1098057	A16MCTUPR11	16	20,0	11,0	150	1/8-27 NPT	TP..110304	SM815	MS961	CKM19	STCM9	2.5 mm
左手												
1098058	A16MCTUPL11	16	20,0	11,0	150	1/8-27 NPT	TP..110304	SM815	MS961	CKM19	STCM9	2.5 mm

● 首选  
 ○ 备选

**CCGT-HP**

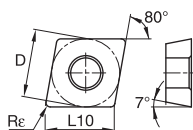
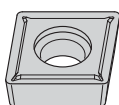
目录编号	D	L10	Rε	KCP05	KCP10B	KCP10	KCP25B	KCP25	KCP30	KCP40	KCK05B	KCK05	KCK15B	KCK15	KCK20B	KCK20	KCM15B	KCM15	KCM25B	KCM25	KCM35	KU10	K313	K68	KCS10	KCU10	KCU25	KC5010	KC5025	KC5410	KT315	KTP10
CCGT060202HP	6,35	6,45	0,2	-	-	-	-	-	-	-	-	-	-	-	-	-	-	-	-	-	-	-	-	-	-	-	-	-	-	-	-	
CCGT060204HP	6,35	6,45	0,4	-	-	-	-	-	-	-	-	-	-	-	-	-	-	-	-	-	-	-	-	-	-	-	-	-	-	-	-	
CCGT060208HP	6,35	6,45	0,8	-	-	-	-	-	-	-	-	-	-	-	-	-	-	-	-	-	-	-	-	-	-	-	-	-	-	-	-	
CCGT09T302HP	9,53	9,67	0,2	-	-	-	-	-	-	-	-	-	-	-	-	-	-	-	-	-	-	-	-	-	-	-	-	-	-	-	-	
CCGT09T304HP	9,53	9,67	0,4	-	-	-	-	-	-	-	-	-	-	-	-	-	-	-	-	-	-	-	-	-	-	-	-	-	-	-	-	
CCGT09T308HP	9,53	9,67	0,8	-	-	-	-	-	-	-	-	-	-	-	-	-	-	-	-	-	-	-	-	-	-	-	-	-	-	-	-	
CCGT120402HP	12,70	12,90	0,2	-	-	-	-	-	-	-	-	-	-	-	-	-	-	-	-	-	-	-	-	-	-	-	-	-	-	-	-	
CCGT120404HP	12,70	12,90	0,4	-	-	-	-	-	-	-	-	-	-	-	-	-	-	-	-	-	-	-	-	-	-	-	-	-	-	-	-	
CCGT120408HP	12,70	12,90	0,8	-	-	-	-	-	-	-	-	-	-	-	-	-	-	-	-	-	-	-	-	-	-	-	-	-	-	-	-	

**CCGT-LF**

目录编号	D	L10	Rε	KCP05	KCP10B	KCP10	KCP25B	KCP25	KCP30	KCP40	KCK05B	KCK05	KCK15B	KCK15	KCK20B	KCK20	KCM15B	KCM15	KCM25B	KCM25	KCM35	KU10	K313	K68	KCS10	KCU10	KCU25	KC5010	KC5025	KC5410	KT315	KTP10
CCGT0602X0LF	6,35	6,45	0,0	-	-	-	-	-	-	-	-	-	-	-	-	-	-	-	-	-	-	-	-	-	-	-	-	-	-	-	-	
CCGT060201LF	6,35	6,45	0,1	-	-	-	-	-	-	-	-	-	-	-	-	-	-	-	-	-	-	-	-	-	-	-	-	-	-	-	-	
CCGT060202LF	6,35	6,45	0,2	-	-	-	-	-	-	-	-	-	-	-	-	-	-	-	-	-	-	-	-	-	-	-	-	-	-	-	-	
CCGT060204LF	6,35	6,45	0,4	-	-	-	-	-	-	-	-	-	-	-	-	-	-	-	-	-	-	-	-	-	-	-	-	-	-	-	-	
CCGT060208LF	6,35	6,45	0,8	-	-	-	-	-	-	-	-	-	-	-	-	-	-	-	-	-	-	-	-	-	-	-	-	-	-	-	-	
CCGT09T3X0LF	9,53	9,67	0,0	-	-	-	-	-	-	-	-	-	-	-	-	-	-	-	-	-	-	-	-	-	-	-	-	-	-	-	-	
CCGT09T301LF	9,53	9,67	0,1	-	-	-	-	-	-	-	-	-	-	-	-	-	-	-	-	-	-	-	-	-	-	-	-	-	-	-	-	
CCGT09T302LF	9,53	9,67	0,2	-	-	-	-	-	-	-	-	-	-	-	-	-	-	-	-	-	-	-	-	-	-	-	-	-	-	-	-	
CCGT09T304LF	9,53	9,67	0,4	-	-	-	-	-	-	-	-	-	-	-	-	-	-	-	-	-	-	-	-	-	-	-	-	-	-	-	-	
CCGT09T308LF	9,53	9,67	0,8	-	-	-	-	-	-	-	-	-	-	-	-	-	-	-	-	-	-	-	-	-	-	-	-	-	-	-	-	









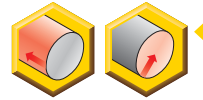
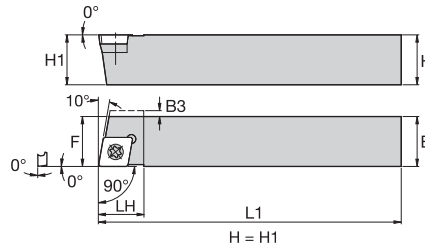
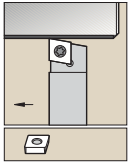

**SCAC 90°**

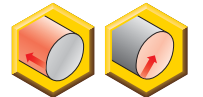
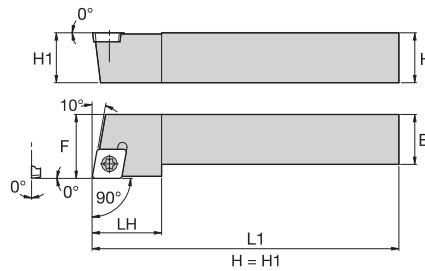
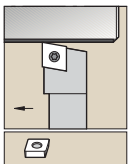
订货号	目录编号	H	B	F	L1	LH	刀片	垫片	垫片螺钉	六角	刀片螺钉	六角
右手												
1097708	SCACR1010M06Q	10	10	10,0	150	11,0	CC..060204	—	—	—	MS1153	T7
1097710	SCACR1212M06Q	12	12	12,0	150	11,0	CC..060204	—	—	—	MS1153	T7
1097714	SCACR1616K09Q	16	16	16,0	125	16,0	CC..09T308	SKCP343	SRS3	3.5 mm	MS1156	T15

**SCGC 90°**

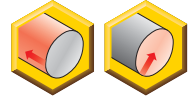
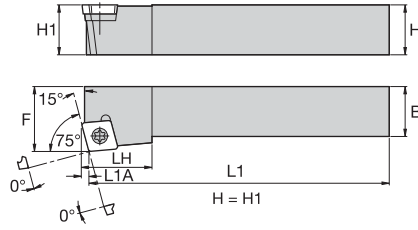
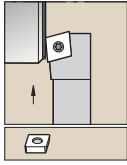

订货号	目录编号	H	B	F	L1	LH	刀片	刀片螺钉	Torx
右手									
1097824	SCGCR1010M06	10	10	12,0	150	11,0	CC..060204	MS1153	T7
1097825	SCGCR1212N09	12	12	16,0	160	16,0	CC..09T308	MS1155	T15
左手									
1097970	SCGCL1212N09	12	12	16,0	160	16,0	CC..09T308	MS1155	T15



■ SCKC 75°

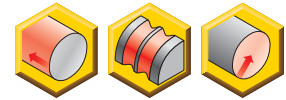
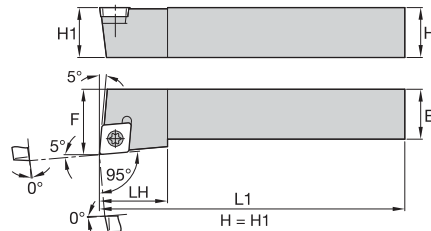
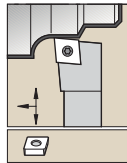

订货号	目录编号	H	B	F	L1	LH	L1A	刀片	垫片	垫片螺钉	六角	刀片螺钉	Torx
右手													
1097840	SCKCR2020K09	20	20	25,0	125	16,0	2,3	CC..09T308	SKCP343	SRS3	3.5 mm	MS1156	T15



■ SCLC 95°

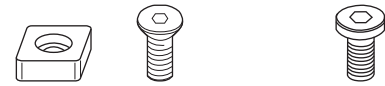

订货号	目录编号	H	B	F	L1	LH	刀片	垫片	垫片螺钉	六角	刀片螺钉	Torx
右手												
1097814	SCLCR0808L06	8	8	10,0	140	12,0	CC..060204	—	—	—	MS1153	T7
1097816	SCLCR1010M06	10	10	12,0	150	12,0	CC..060204	—	—	—	MS1153	T7
1097818	SCLCR1212N09	12	12	16,0	160	16,0	CC..09T308	—	—	—	MS1155	T15
1097819	SCLCR1616H09	16	16	20,0	100	15,8	CC..09T308	SKCP343	SRS3	3.5 mm	MS1156	T15
1097821	SCLCR2020K09	20	20	25,0	125	15,8	CC..09T308	SKCP343	SRS3	3.5 mm	MS1156	T15
1097820	SCLCR2020K12	20	20	25,0	125	19,8	CC..120408	SKCP453	SRS4	4 mm	MS1158	T15
1244995	SCLCR2525M09	25	25	32,0	150	15,8	CC..09T308	SKCP343	SRS3	3.5 mm	MS1156	T15
1097822	SCLCR2525M12	25	25	32,0	150	20,0	CC..120408	SKCP453	SRS4	4 mm	MS1158	T15
左手												
1097959	SCLCL0808L06	8	8	10,0	140	12,0	CC..060204	—	—	—	MS1153	T7
1097961	SCLCL1010M06	10	10	12,0	150	12,0	CC..060204	—	—	—	MS1153	T7
1097963	SCLCL1212N09	12	12	16,0	160	16,0	CC..09T308	—	—	—	MS1155	T15
1097964	SCLCL1616H09	16	16	20,0	100	15,8	CC..09T308	SKCP343	SRS3	3.5 mm	MS1156	T15
1097966	SCLCL2020K09	20	20	25,0	125	15,8	CC..09T308	SKCP343	SRS3	3.5 mm	MS1156	T15
1097965	SCLCL2020K12	20	20	25,0	125	19,8	CC..120408	SKCP453	SRS4	4 mm	MS1158	T15
1318353	SCLCL2525M09	25	25	32,0	150	15,8	CC..09T308	SKCP343	SRS3	3.5 mm	MS1156	T15
1097967	SCLCL2525M12	25	25	32,0	150	20,0	CC..120408	SKCP453	SRS4	4 mm	MS1158	T15

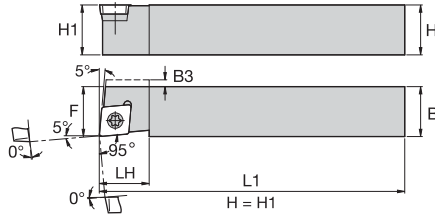
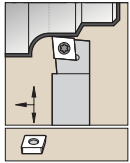
**■ SCLC-F 95°**

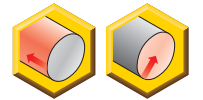
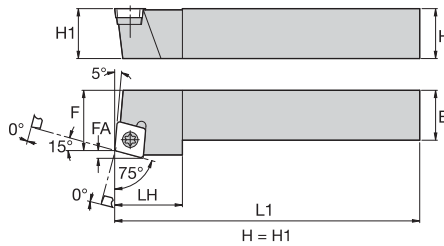
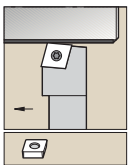

订货号	目录编号	H	B	F	L1	LH	B3	刀片	垫片	垫片螺钉	六角	刀片螺钉	Torx
右手													
1772152	SCLCRF0808M06Q	8	8	8,0	150	12,0	1,5	CC..060204	—	—	—	MS1153	T7
1097812	SCLCRF1010M06Q	10	10	10,0	150	11,0	—	CC..060204	—	—	—	MS1153	T7
1097813	SCLCRF1212M06Q	12	12	12,0	150	11,0	—	CC..060204	—	—	—	MS1153	T7
1097817	SCLCRF1616K09Q	16	16	16,0	125	16,0	—	CC..09T308	SKCP343	SRS3	3.5 mm	MS1156	T15

**■ SCRC 75°**

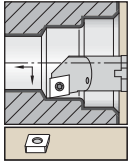
订货号	目录编号	H	B	F	L1	LH	FA	刀片	垫片	垫片螺钉	六角	刀片螺钉	Torx
右手													
1097828	SCRCR1212N09	12	12	13,0	160	14,0	2,3	CC..09T308	—	—	—	MS1155	T15
1097829	SCRCR1616H09	16	16	17,0	100	14,0	2,3	CC..09T308	SKCP343	SRS3	3.5 mm	MS1156	T15

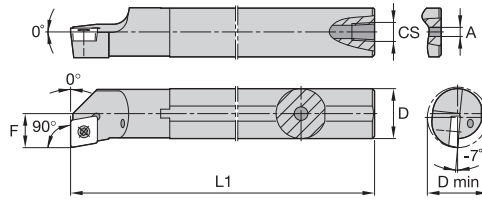

带内冷功能的钢质刀柄。



■ A-SCFC 90°



订货号	目录编号	D	D min	F	L1	CS	刀片	刀片螺钉	Torx
右手									
1098266	A25TSCFCR12	25	32,0	17,0	300	1/4-18 NPT	CC..120408	MS1157	T15
左手									
1098270	A25TSCFCL12	25	32,0	17,0	300	1/4-18 NPT	CC..120408	MS1157	T15

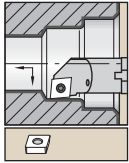

带内冷功能的钢质刀柄。

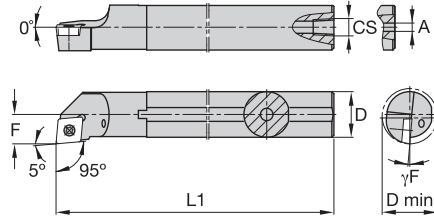

■ A-SCLC 95°

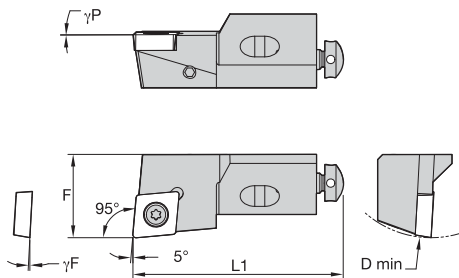
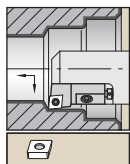

订货号	目录编号	D	D min	F	L1	A	CS	γF°	刀片	垫片	垫片螺钉	六角	刀片螺钉	Torx
右手														
1098159	A08JSCLCR06	8	11,0	6,0	110	2,4	—	-8.0	CC..060204	—	—	—	MS1939	T7
1098168	A10KSCLCR06	10	13,0	7,0	125	3,2	—	-7.0	CC..060204	—	—	—	MS1153	T7
1098178	A12MSCLCR06	12	16,0	9,0	150	4,0	1/16-27 NPT	-6.0	CC..060204	—	—	—	MS1153	T7
1098225	A16RSCLCR09	16	20,0	11,0	200	4,0	1/8-27 NPT	-7.0	CC..09T308	—	—	—	MS1155	T15
1098239	A20SSCLCR09	20	25,0	13,0	250	4,0	1/8-27 NPT	-5.0	CC..09T308	—	—	—	MS1155	T15
1098268	A25TSCLCR12	25	32,0	17,0	300	6,4	1/4-18 NPT	-7.0	CC..120408	—	—	—	MS1157	T15
1098280	A32TSCLCR12	32	40,0	22,0	300	6,4	1/4-18 NPT	-7.0	CC..120408	SKCP453	SRS4	4 mm	MS1158	T15
左手														
1098163	A08JSCLCL06	8	11,0	6,0	110	2,4	—	-8.0	CC..060204	—	—	—	MS1939	T7
1098173	A10KSCLCL06	10	13,0	7,0	125	3,2	—	-7.0	CC..060204	—	—	—	MS1153	T7
1098183	A12MSCLCL06	12	16,0	9,0	150	4,0	1/16-27 NPT	-6.0	CC..060204	—	—	—	MS1153	T7
1098231	A16RSCLCL09	16	20,0	11,0	200	4,0	1/8-27 NPT	-7.0	CC..09T308	—	—	—	MS1155	T15
1098244	A20SSCLCL09	20	25,0	13,0	250	4,0	1/8-27 NPT	-5.0	CC..09T308	—	—	—	MS1155	T15
1098272	A25TSCCL12	25	32,0	17,0	300	6,4	1/4-18 NPT	-7.0	CC..120408	—	—	—	MS1157	T15
1098282	A32TSCCL12	32	40,0	22,0	300	6,4	1/4-18 NPT	-7.0	CC..120408	SKCP453	SRS4	4 mm	MS1158	T15

**■ SCLC 95°**

订货号	目录编号	D min	F	L1	γF°	γP°	刀片
<b>右手</b>							
1098544	SCLCR12CA12	50	20,0	55	-3.0	0.0	CC..120408/CC..432
1098545	SCLCR16CA12	60	25,0	63	-3.0	0.0	CC..120408/CC..432
<b>左手</b>							
1098732	SCLCL12CA12	50	20,0	55	-3.0	0.0	CC..120408/CC..432

**■ 配件**

D min	刀片螺钉	Torx	径向调节螺钉	六角	轴向调节螺钉	安装螺钉	六角	垫片
50	MS1157	T15	KUAM23	2.5 mm	KUAM31	191.406	4 mm	CSWM 060 050
60	MS1157	T15	KUAM25	2.5 mm	KUAM32	191.407	5 mm	CSWM 080 050

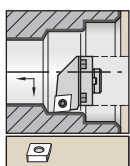
**螺纹接口镗头**

带有内冷。

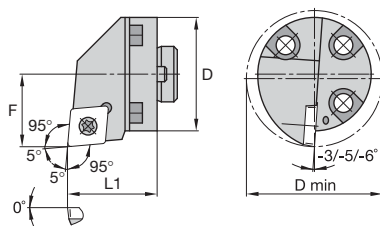
**■ H-SCLC 95°**



订货号	目录编号	D	D min	F	L1	刀片	刀片螺钉	Torx
<b>右手</b>								
1772253	H32SCLCR09	32	40,0	21,9	25	CC..09T308	MS1155	T15
3612090	H40SCLCR12	40	50,0	27,0	41	CC..120408	MS1158	T15



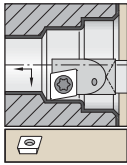
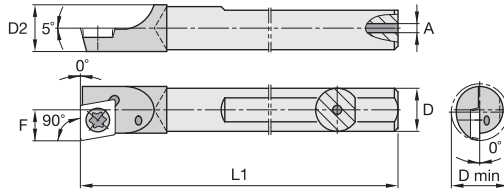

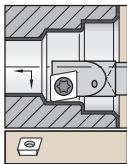
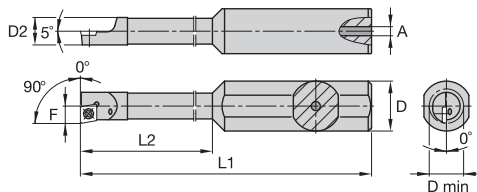

 硬质合金刀柄  
 (带内冷功能)。

**E-SCFD 90°**

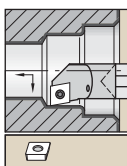
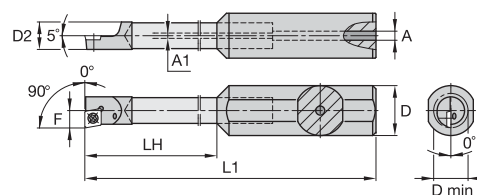

订货号	目录编号	D	D min	F	L1	A	刀片	刀片螺钉	Torx
右手									
1930354	E05HSCFDRS4	5	5,9	3,2	101	1,0	CD..S4T002	CC11	T6
1930360	E06HSCFDRS4	6	7,1	3,7	100	1,2	CD..S4T002	CC11	T6

 带有内冷的缩颈钢  
 刀柄。

**A-SCFD 90° • 阶梯**

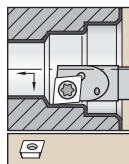

订货号	目录编号	D	D min	D2	F	L1	L2	A	刀片	刀片螺钉	Torx
右手											
1930376	A0510ESCFDRS412	10	5,9	5,2	3,1	70	12,7	1,0	CD..S4T002	CC11	T6
1930380	A0510ESCFDRS425	10	5,9	5,2	3,1	70	25,4	1,0	CD..S4T002	CC11	T6
1930404	A0612ESCFDRS431	12	7,4	6,6	3,9	70	31,8	1,0	CD..S4T002	CC11	T6

 带有内冷的缩颈硬  
 质合金刀柄。

**E-SCFD 90° • 阶梯**

订货号	目录编号	D	D min	D2	F	L1	LH	A	A1	刀片	刀片螺钉	Torx
右手												
1930408	E0512XSCFDRS425	12	5,9	5,0	3,2	64	10,0	1,0	1,2	CD..S4T002	CC11	T6
1930412	E0512XSCFDRS450	12	5,9	5,0	3,2	89	10,0	3,2	1,2	CD..S4T002	CC11	T6
1930436	E0616XSCFDRS463	16	7,4	6,3	3,9	127	12,3	3,2	1,2	CD..S4T002	CC11	T6

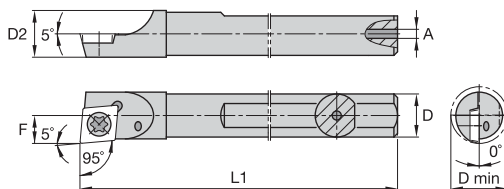

带内冷功能的钢质刀柄。



■ A-SCLD 95°



订货号	目录编号	D	D min	D2	F	L1	A	刀片	刀片螺钉	Torx
右手										
1288877	A04XSCLDRS4	4	4,6	4,2	2,4	65	1,0	CD..S4T002	CC09	T6
1930298	A05XSCLDRS4	5	5,8	5,2	3,0	64	1,0	CD..S4T002	CC09	T6
1288893	A06XSCLDRS4	6	7,1	6,2	3,7	64	1,0	CD..S4T002	CC11	T6
1288906	A08XSCLDRS4	8	9,0	8,2	4,7	76	1,5	CD..S4T002	CC11	T6
左手										
1288876	A04XSCLDLS4	4	4,6	4,2	2,4	65	1,0	CD..S4T002	CC09	T6
1930297	A05XSCLDLS4	5	5,8	5,2	3,0	64	1,0	CD..S4T002	CC09	T6
1288892	A06XSCLDLS4	6	7,1	6,2	3,7	64	1,0	CD..S4T002	CC11	T6
1288905	A08XSCLDLS4	8	9,0	8,2	4,7	76	1,5	CD..S4T002	CC11	T6

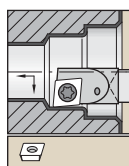

硬质合金刀柄  
(带内冷功能)。

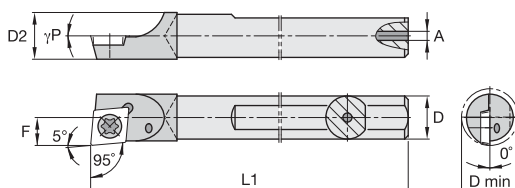

■ E-SCLD 95°

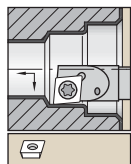
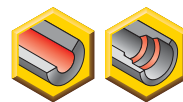
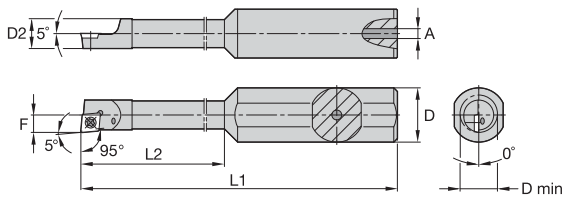

订货号	目录编号	D	D min	D2	F	L1	A	γP°	刀片	刀片螺钉	Torx
右手											
1930300	E04HSCLDRS4	4	4,6	4,2	2,4	100	1,0	0.0	CD..S4T002	CC09	T6
1270967	E04MSCLDRS4	4	4,6	4,2	2,4	152	1,0	0.0	CD..S4T002	CC09	T6
1930356	E05HSCLDRS4	5	5,9	—	3,0	101	1,0	5.0	CD..S4T002	CC09	T6
1930358	E05MSCLDRS4	5	5,9	—	3,0	152	1,0	5.0	CD..S4T002	CC09	T6
1930362	E06HSCLDRS4	6	7,1	—	3,7	100	1,2	5.0	CD..S4T002	CC11	T6
1270978	E06MSCLDRS4	6	6,9	—	3,7	152	1,2	5.0	CD..S4T002	CC09	T6
1270988	E08MSCLDRS4	8	9,1	—	4,7	150	2,4	5.0	CD..120605	CC11	T6
左手											
1930299	E04HSCLDLS4	4	4,6	4,2	2,4	100	1,0	0.0	CD..S4T002	CC09	T6
1270966	E04MSCLDLS4	4	4,6	4,2	2,4	152	1,0	0.0	CD..S4T002	CC09	T6
1930355	E05HSCLDLS4	5	5,9	—	3,0	101	1,0	5.0	CD..S4T002	CC11	T6
1930357	E05MSCLDLS4	5	5,9	—	3,0	152	1,0	5.0	CD..S4T002	CC09	T6
1930361	E06HSCLDLS4	6	7,1	—	3,7	100	1,2	5.0	CD..S4T002	CC11	T6
1270977	E06MSCLDLS4	6	7,1	—	3,7	152	1,2	5.0	CD..S4T002	CC11	T6
1270987	E08MSCLDLS4	8	9,0	—	4,7	152	2,4	5.0	CD..S4T002	CC11	T6

 缩颈钢柄,  
 带内冷功能。

**A-SCLD 95° • 阶梯**

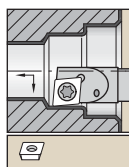
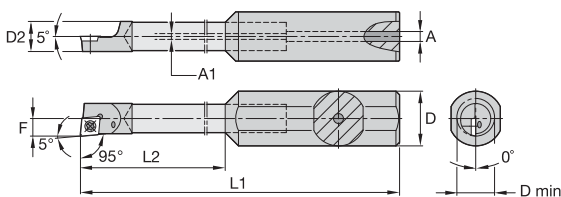

订货号	目录编号	D	D min	F	L1	L2	A	刀片	刀片螺钉	Torx
右手										
1930372	A0410ESCLDRS412	10	5,2	2,6	70	12,7	1,0	CD..S4T002	CC09	T6
1930374	A0410ESCLDRS425	10	5,2	2,6	70	25,4	1,0	CD..S4T002	CC09	T6
1289129	A0412ESCLDRS412	12	5,2	2,6	70	12,7	1,0	CD..S4T002	CC09	T6
1289130	A0412ESCLDRS425	12	5,2	2,6	70	25,4	1,0	CD..S4T002	CC09	T6
1930378	A0510ESCLDRS412	10	5,8	3,0	70	12,3	1,0	CD..S4T002	CC11	T6
1930382	A0510ESCLDRS425	10	5,8	3,0	70	25,0	1,0	CD..S4T002	CC09	T6
1098071	A0510GSCLDRS4	10	6,0	3,2	90	25,0	3,2	CD..S4T002	MS1454	T5
1098073	A0610HSCLDRS4	10	7,6	3,8	100	32,0	3,2	CD..S4T002	MS1454	T5
1930402	A0612ESCLDRS419	12	7,2	3,7	70	19,1	1,0	CD..S4T002	CC11	T6

 缩颈硬质合金柄,  
 带内冷功能。

**E-SCLD 95° • 阶梯**

订货号	目录编号	D	D min	D2	F	L1	L2	A	刀片	刀片螺钉	Torx
右手											
1930406	E0412DSCLDRS422	12	5,3	5,0	2,6	60	22,2	3,2	CD..S4T002	CC09	T6
1262129	E0412XSCLDRS447	12	5,3	5,0	2,6	86	47,6	3,2	CD..S4T002	CC09	T6
1262131	E0416KSCLDRS447	16	5,3	5,0	2,6	111	47,6	3,2	CD..S4T002	CC09	T6
1930410	E0512XSCLDRS425	12	5,9	—	3,0	64	25,4	1,0	CD..S4T002	CC11	T6
1930418	E0612ESCLDRS431	12	7,2	—	3,7	70	31,8	3,2	CD..S4T002	CC11	T6
1262178	E0612HSCLDRS463	12	7,2	—	3,7	102	63,5	3,2	CD..S4T002	CC11	T6
1930434	E0616HSCLDRS431	16	7,2	—	3,7	95	31,8	3,2	CD..S4T002	CC11	T6
1262175	E0616XSCLDRS463	16	7,2	—	3,7	127	63,5	3,2	CD..120605	CC11	T6

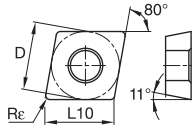
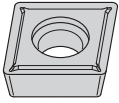

● 首选  
○ 备选



■ CPGT-LF

目录编号	D	L10	Rε	KCP05	KCP10B	KCP10	KCP25B	KCP25	KCP30	KCP40	KCK05B	KCK05	KCK15B	KCK15	KCK20B	KCK20	KCM15B	KCM15	KCM25B	KCM25	KCM35	KU10	K313	K68	KCS10	KCU10	KCU25	KC5010	KC5025	KC5410	KT315	KTP10
CPGT060201LF	6,35	6,45	0,1	-	-	-	-	-	-	-	-	-	-	-	-	-	-	-	-	-	-	-	-	-	-	-	-	-	-	-	-	-
CPGT060202LF	6,35	6,45	0,2	-	-	-	-	-	-	-	-	-	-	-	-	-	-	-	-	-	-	-	-	-	-	-	-	-	-	-	-	-
CPGT060204LF	6,35	6,45	0,4	-	-	-	-	-	-	-	-	-	-	-	-	-	-	-	-	-	-	-	-	-	-	-	-	-	-	-	-	-
CPGT060208LF	6,35	6,45	0,8	-	-	-	-	-	-	-	-	-	-	-	-	-	-	-	-	-	-	-	-	-	-	-	-	-	-	-	-	-
CPGT09T302LF	9,53	9,67	0,2	-	-	-	-	-	-	-	-	-	-	-	-	-	-	-	-	-	-	-	-	-	-	-	-	-	-	-	-	-
CPGT09T304LF	9,53	9,67	0,4	-	-	-	-	-	-	-	-	-	-	-	-	-	-	-	-	-	-	-	-	-	-	-	-	-	-	-	-	-
CPGT09T308LF	9,53	9,67	0,8	-	-	-	-	-	-	-	-	-	-	-	-	-	-	-	-	-	-	-	-	-	-	-	-	-	-	-	-	-

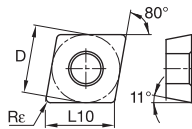

■ CPMT-FP

目录编号	D	L10	Rε	KCP05	KCP10B	KCP10	KCP25B	KCP25	KCP30	KCP40	KCK05B	KCK05	KCK15B	KCK15	KCK20B	KCK20	KCM15B	KCM15	KCM25B	KCM25	KCM35	KU10	K313	K68	KCS10	KCU10	KCU25	KC5010	KC5025	KC5410	KT315	KTP10
CPMT050202FP	5,56	5,65	0,2	-	-	-	-	-	-	-	-	-	-	-	-	-	-	-	-	-	-	-	-	-	-	-	-	-	-	-	-	-
CPMT050204FP	5,56	5,65	0,4	-	-	-	-	-	-	-	-	-	-	-	-	-	-	-	-	-	-	-	-	-	-	-	-	-	-	-	-	-
CPMT060202FP	6,35	6,45	0,2	-	-	-	-	-	-	-	-	-	-	-	-	-	-	-	-	-	-	-	-	-	-	-	-	-	-	-	-	-
CPMT060204FP	6,35	6,45	0,4	-	-	-	-	-	-	-	-	-	-	-	-	-	-	-	-	-	-	-	-	-	-	-	-	-	-	-	-	-
CPMT060208FP	6,35	6,45	0,8	-	-	-	-	-	-	-	-	-	-	-	-	-	-	-	-	-	-	-	-	-	-	-	-	-	-	-	-	-
CPMT09T302FP	9,53	9,67	0,2	-	-	-	-	-	-	-	-	-	-	-	-	-	-	-	-	-	-	-	-	-	-	-	-	-	-	-	-	-
CPMT09T304FP	9,53	9,67	0,4	-	-	-	-	-	-	-	-	-	-	-	-	-	-	-	-	-	-	-	-	-	-	-	-	-	-	-	-	-
CPMT09T308FP	9,53	9,67	0,8	-	-	-	-	-	-	-	-	-	-	-	-	-	-	-	-	-	-	-	-	-	-	-	-	-	-	-	-	-

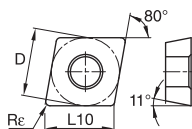
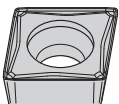

■ CPMT-FW

目录编号	D	L10	Rε	KCP05	KCP10B	KCP10	KCP25B	KCP25	KCP30	KCP40	KCK05B	KCK05	KCK15B	KCK15	KCK20B	KCK20	KCM15B	KCM15	KCM25B	KCM25	KCM35	KU10	K313	K68	KCS10	KCU10	KCU25	KC5010	KC5025	KC5410	KT315	KTP10
CPMT060202FW	6,35	6,45	0,2	-	-	-	-	-	-	-	-	-	-	-	-	-	-	-	-	-	-	-	-	-	-	-	-	-	-	-	-	-
CPMT060204FW	6,35	6,45	0,4	-	-	-	-	-	-	-	-	-	-	-	-	-	-	-	-	-	-	-	-	-	-	-	-	-	-	-	-	-
CPMT060208FW	6,35	6,45	0,8	-	-	-	-	-	-	-	-	-	-	-	-	-	-	-	-	-	-	-	-	-	-	-	-	-	-	-	-	-
CPMT09T304FW	9,53	9,67	0,4	-	-	-	-	-	-	-	-	-	-	-	-	-	-	-	-	-	-	-	-	-	-	-	-	-	-	-	-	-
CPMT09T308FW	9,53	9,67	0,8	-	-	-	-	-	-	-	-	-	-	-	-	-	-	-	-	-	-	-	-	-	-	-	-	-	-	-	-	-





ISO 车削刀具

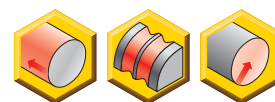
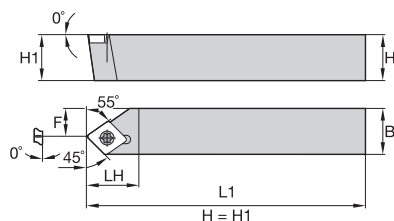
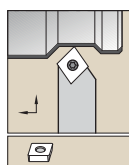

■ SCDP 45°



订货号	目录编号	H	B	F	L1	LH	刀片	刀片螺钉	Torx
右手									
1244893	SCDPR1212H06	12	12	7,0	100	14,0	CP..060203	MS1153	T7

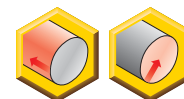
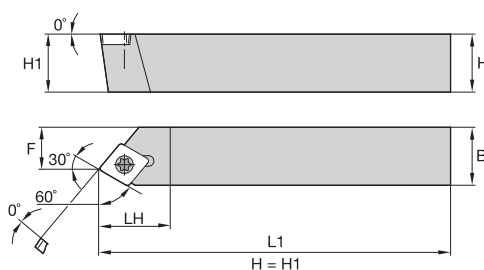
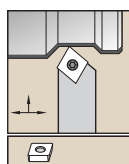

■ SCEP 60°



订货号	目录编号	H	B	F	L1	LH	刀片	刀片螺钉	Torx
右手									
1244896	SCEPR1010H06	10	10	6,5	100	12,0	CP..060203R.	MS1153	T7
1250901	SCEPR1212H06	12	12	8,5	100	12,0	CP..060203R.	MS1153	T7



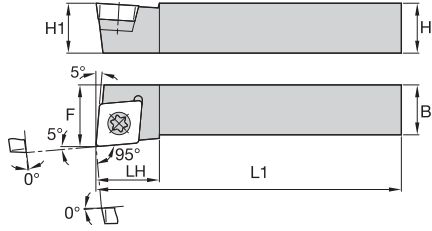
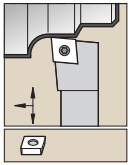

**SCLP 95°**

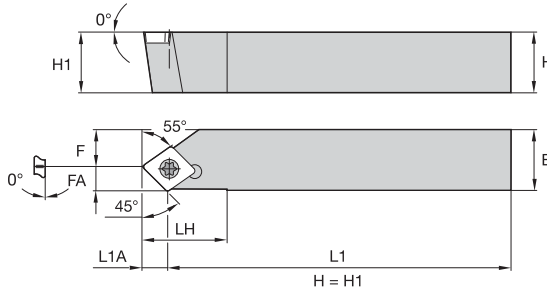
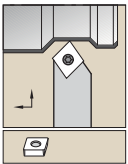

订货号	目录编号	H	B	F	L1	LH	刀片	刀片螺钉	Torx
右手									
1192469	SCLPR1212M06	12	12	13,0	150	11,4	CP..060203	MS1153	T7
左手									
1244913	SCLPL1212M06	12	12	13,0	150	11,4	CP..060203	MS1153	T7

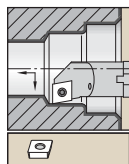
**SCSP 45°**

订货号	目录编号	H	B	F	L1	LH	FA	L1A	刀片	刀片螺钉	Torx
右手											
1244917	SCSPR1010H06	10	10	6,0	100	14,0	4,2	4,2	CP..060203	MS1153	T7

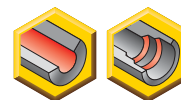
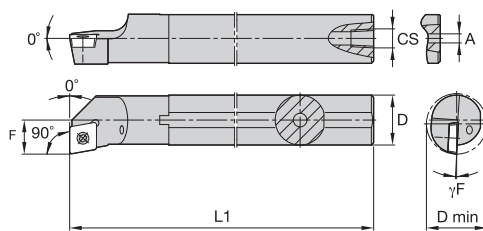

带有内冷的钢刀柄。



■ A-SCFP 90°



订货号	目录编号	D	D min	F	L1	A	CS	γF°	刀片	刀片螺钉	Torx
右手											
1098157	A08JSCFPR06	8	11,0	6,0	110	2,4	—	-8.0	CP..060204	MS1153	T7
1098165	A10KSCFPR06	10	13,0	7,0	125	3,2	—	-6.0	CP..060204	MS1153	T7
1098175	A12MSCFPR06	12	16,0	9,0	150	4,0	1/16-27 NPT	-4.0	CP..060204	MS1153	T7
1886498	A16RSCFPR06	16	20,0	11,0	200	—	1/8-27 NPT	-5.0	CP..060203	MS1153	T7
1098221	A16RSCFPR09	16	20,0	11,0	200	4,0	1/8-27 NPT	-4.0	CP..09T308	MS1155	T15
1098235	A20SSCFPR09	20	25,0	13,0	250	4,0	1/8-27 NPT	-2.0	CP..09T308	MS1155	T15
左手											
1098161	A08JSCFPL06	8	11,0	6,0	110	2,4	—	-8.0	CP..060204	MS1153	T7
1098170	A10KSCFPL06	10	13,0	7,0	125	3,2	—	-6.0	CP..060204	MS1153	T7
1098180	A12MSCFPL06	12	16,0	9,0	150	4,0	1/16-27 NPT	-4.0	CP..060204	MS1153	T7
1098227	A16RSCFPL09	16	20,0	11,0	200	4,0	1/8-27 NPT	-4.0	CP..09T308	MS1155	T15
1098241	A20SSCFPL09	20	25,0	13,0	250	4,0	1/8-27 NPT	-2.0	CP..09T308	MS1155	T15

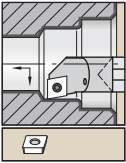

带有内冷的硬质合金刀柄。

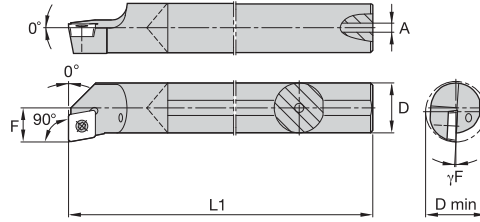

ISO 车削刀具

**E-SCFP 90°**

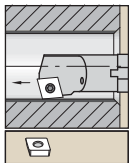

订货号	目录编号	D	D min	F	L1	A	$\gamma_F^\circ$	刀片	刀片螺钉	Torx
右手										
1152852	E08KSCFPR06A	8	11,0	6,0	125	2,4	-8,0	CP..060204	MS1939	T7
1152854	E10MSCFPR06A	10	13,0	7,0	150	3,2	-4,0	CP..060204	MS1939	T7
1152888	E12QSCFPR06	12	16,0	9,0	180	4,8	-3,0	CP..060204	MS1153	T7
左手										
1152853	E08KSCFPL06A	8	11,0	6,0	125	2,4	-8,0	CP..060204	MS1939	T7

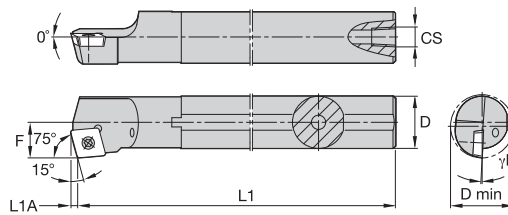

带有内冷的钢刀柄。

**A-SCKP 75°**

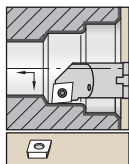
订货号	目录编号	D	D min	F	L1	L1A	CS	$\gamma_F^\circ$	刀片	刀片螺钉	Torx
右手											
1098236	A20SSCKPR09	20	25,0	13,0	250	2,3	1/8-27 NPT	-3,0	CP..09T308	MS1155	T15



带内冷功能的钢质刀柄。

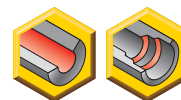
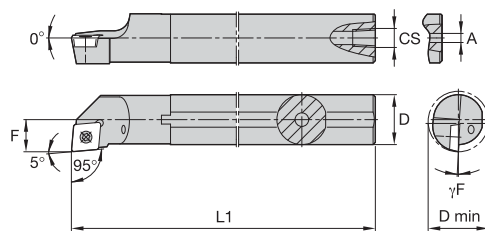

■ A-SCLP 95°



订货号	目录编号	D	D min	F	L1	A	CS	γF°	刀片	刀片螺钉	Torx
右手											
1098156	A08JSCLPR06	.315	.433	.236	4.33	.09	—	-6.0	CP..060204	MS1939	T7
1098164	A10KSCLPR06	.390	.512	.276	4.92	.13	—	-4.0	CP..060204	MS1939	T7
1098174	A12MSCLPR06	.472	.630	.354	5.91	.16	1/16-27 NPT	-3.0	CP..060204	MS1153	T7
1886502	A16RSCLPR06	.630	.787	.433	7.87	—	1/8-27 NPT	-5.0	CP..060203	MS1153	T7
1098220	A16RSCLPR09	.630	.787	.433	7.87	.16	1/8-27 NPT	-4.0	CP..09T308	MS1155	T15
1098234	A20SSCLPR09	.787	.984	.512	9.84	.16	1/8-27 NPT	-2.0	CP..09T308	MS1155	T15
1886504	A20SSCLPR06	.787	.984	.512	9.84	—	1/8-27 NPT	-3.0	CP..060203	MS1153	T7
左手											
1098160	A08JSCLPL06	.315	.433	.236	4.33	.09	—	-6.0	CP..060204	MS1939	T7
1098169	A10KSCLPL06	.390	.512	.276	4.92	.13	—	-4.0	CP..060204	MS1939	T7
1098179	A12MSCLPL06	.472	.630	.354	5.91	.16	1/16-27 NPT	-3.0	CP..060204	MS1153	T7
1886501	A16RSCLPL06	.630	.787	.433	7.87	—	1/8-27 NPT	-5.0	CP..060203	MS1153	T7
1098226	A16RSCLPL09	.630	.787	.433	7.87	.16	1/8-27 NPT	-4.0	CP..09T308	MS1155	T15
1098240	A20SSCLPL09	.787	.984	.512	9.84	.16	1/8-27 NPT	-2.0	CP..09T308	MS1155	T15

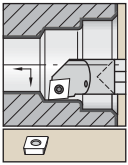

硬质合金刀柄 (带内冷功能)。

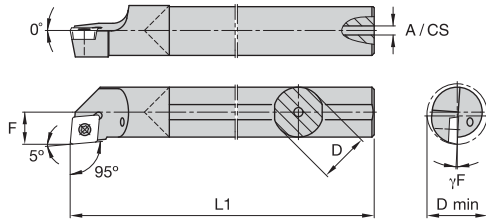

## ■ E-SCLP 95°



订货号	目录编号	D	D min	F	L1	A	γF°	刀片	刀片螺钉	Torx
右手										
1152856	E08KSCLPR06A	8	11,0	6,0	122	2,4	-6.0	CP..060204	MS1939	T7
1152858	E10MSCLPR06A	10	13,0	7,0	150	3,2	-4.0	CP..060204	MS1939	T7
1152889	E12QSCLPR06	12	16,0	9,0	180	4,8	-3.0	CP..060204	MS1153	T7
1152897	E16RSCLPR09	16	20,0	11,0	200	5,5	-4.0	CP..09T308	MS1155	T15
1152902	E20SSCLPR09	20	25,0	13,0	250	7,1	-2.0	CP..09T308	MS1155	T15
左手										
1152857	E08KSCLPL06A	8	11,0	6,0	122	2,4	-6.0	CP..060204	MS1939	T7
1152859	E10MSCLPL06A	10	13,0	7,0	150	3,2	-4.0	CP..060204	MS1939	T7
1152891	E12QSCLPL06	12	16,0	9,0	180	4,8	-3.0	CP..060204	MS1153	T7
1152899	E16RSCLPL09	16	20,0	11,0	200	5,5	-4.0	CP..09T308	MS1155	T15
1152905	E20SSCLPL09	20	25,0	13,0	250	7,1	-2.0	CP..09T308	MS1155	T15

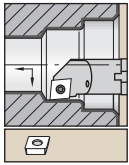

重金属镗杆，带内冷功能。

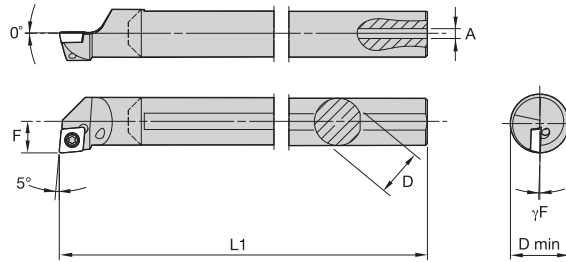

■ L-SCLP 95°



订货号	目录编号	D	D min	F	L1	A	γF°	刀片	刀片螺钉	Torx
右手										
3331115	L08KSCLPR06	8	11,0	6,0	123	2,4	-6.0	CP..060204..	MS1939	T7
3331107	L10MSCLPR06	10	13,0	7,0	149	3,2	-4.0	CP..060204..	MS1939	T7
3331110	L12QSCLPR06	12	16,0	9,0	181	4,0	-3.0	CP..060204..	MS1153	T7
3331108	L16RSCLPR09	16	20,0	11,0	203	4,0	-4.0	CP..09T308..	MS1155	T15
3331106	L20SSCLPR09	20	25,0	13,0	251	4,0	-2.0	CP..09T308..	MS1155	T15
左手										
3331112	L12QSCLPL06	12	16,0	9,0	181	4,0	-3.0	CP..060204..	MS1153	T7
3331114	L16RSCLPL09	16	20,0	11,0	203	4,0	-4.0	CP..09T308..	MS1155	T15
3331109	L20SSCLPL09	20	25,0	13,0	251	4,0	-2.0	CP..09T308..	MS1155	T15

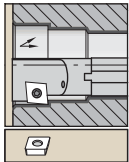

带内冷功能的钢质刀柄。

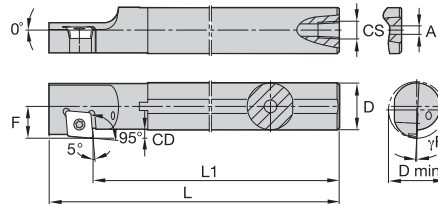

■ A-SCXP 95°



订货号	目录编号	D	D min	F	L1	L	A	CS	γF°	刀片	刀片螺钉	Torx
右手												
1098167	A10KSCXPR06	10	13,0	7,0	125	136,0	3,2	—	-4.0	CP..060204	MS1153	T7
1098177	A12MSCXPR06	12	16,0	9,0	150	161,0	4,0	1/16-27 NPT	-3.0	CP..060204	MS1153	T7
1098223	A16RSXPR09	16	20,0	11,0	200	218,0	4,0	1/8-27 NPT	-4.0	CP..09T308	MS1155	T15

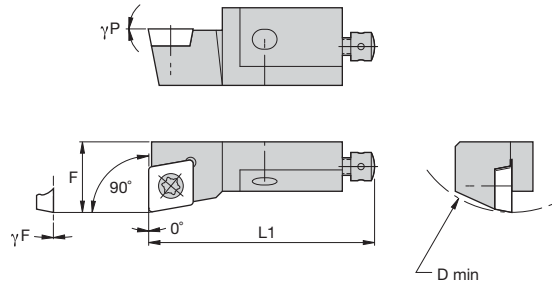
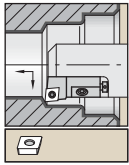

### ■ SCFP 90°

订货号	目录编号	D min	F	L1	γF°	γP°	刀片
<b>右手</b>							
1098551	SCFPR06CA05	20	8,0	25	0.0	0.0	CP..050204/CP..18151
1082671	SCFPR08CA06	25	10,0	32	0.0	0.0	CP..060204/CP..2151
1797235	SCFPR10CA09	40	14,0	50	0.0	0.0	CP..09T308/CP..3252
<b>左手</b>							
1098766	SCFPL08CA06	25	10,0	32	0.0	0.0	CP..060204/CP..2151

注: ANSI/ISO 兼容 60° 埋头孔加工刀片。  
 这款刀具还可应用 CPGM/CPGT/CPGW-21.5\_ 刀片。

### ■ 配件



D min	刀片螺钉	Torx	径向调节螺钉	六角	轴向调整螺钉	安装螺钉	六角	垫片
20	MS1933	T7	KUAM34	1.5 mm	KUAM35	MS2173	2 mm	CSWM 035 040
25	MS1153	T7	KUAM34	1.5 mm	KUAM20	MS2175	2.5 mm	CSWM 040 050
40	MS1155	T15	KUAM28	2 mm	KUAM30	191.405	4 mm	CSWM 060 050

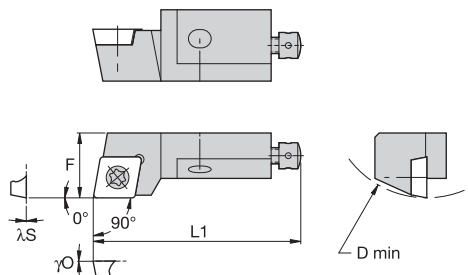
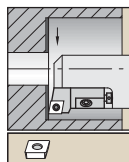

■ SCGP 90°

订货号	目录编号	D min	F	L1	λS°	γO°	刀片
右手							
1098554	SCGPR08CA06	25	10,0	32	0.0	0.0	CP..060204/CP..2151

注: ANSI/ISO 兼容 60° 埋头孔加工刀片。  
这款刀具还可应用 CPGM/CPGT/CPGW-21.5\_ 刀片。

■ 配件



D min	刀片螺钉	Torx	径向调节螺钉	六角	轴向调整螺钉	安装螺钉	六角	垫片
25	MS1153	T7	KUAM34	1.5 mm	KUAM20	MS2175	2.5 mm	CSWM 040 050



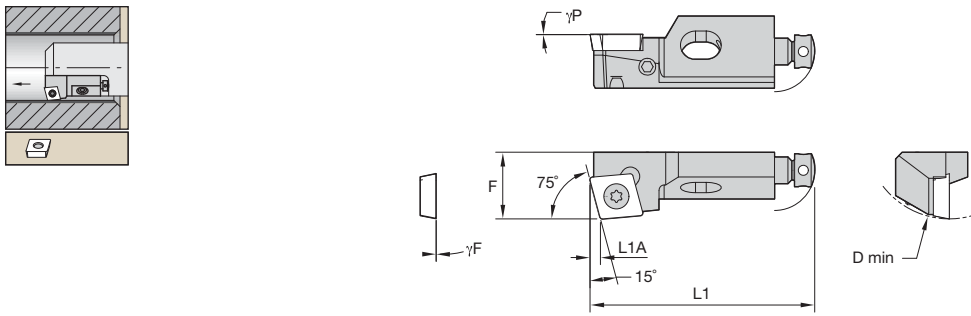

### ■ SCKP 75°

订货号	目录编号	D min	F	L1	L1A	γF°	γP°	刀片
右手								
1098552	SCKPR08CA06	25	10,0	32	1,6	0.0	0.0	CP..060204/CP..2151
左手								
1098763	SCKPL08CA06	25	10,0	32	1,6	0.0	0.0	CP..060204/CP..2151

注: ANSI/ISO 兼容 60° 埋头孔加工刀片。  
 这款刀具还可应用 CPGM/CPGT/CPGW-21.5\_ 刀片。

### ■ 配件



D min	刀片螺钉	Torx	径向调节螺钉	六角	轴向调整螺钉	安装螺钉	六角	垫片
25	MS1153	T7	KUAM34	1.5 mm	KUAM20	MS2175	2.5 mm	CSWM 040 050

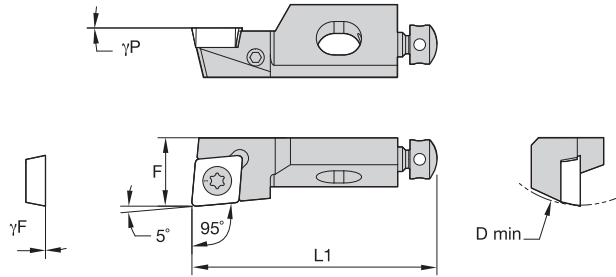
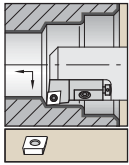

■ SCLP 95°

订货号	目录编号	D min	F	L1	γF°	γP°	刀片
<b>右手</b>							
1098541	SCLPR06CA05	20	8,0	25	0.0	0.0	CP..050204/CP..18151
1098542	SCLPR08CA06	25	10,0	32	0.0	0.0	CP..060204/CP..2151
1098543	SCLPR10CA09	40	14,0	50	0.0	0.0	CP..09T308/CP..3252
<b>左手</b>							
1098730	SCLPL08CA06	25	10,0	32	0.0	0.0	CP..060204/CP..2151
1098731	SCLPL10CA09	40	14,0	50	0.0	0.0	CP..09T308/CP..3252

注: ANSI/ISO 兼容 60° 埋头孔加工刀片。  
这款刀具还可应用 CPGM/CPGT/CPGW-21.5\_ 刀片。  
ANSI/ISO 兼容 60° 埋头孔加工刀片 (i.e., CPMT/CPGT/CPGW-32.5\_)。  
90° 埋头孔加工刀片 (i.e., CPGM/CPGB-32.5\_) 不适合这款刀具。

■ 配件



D min	刀片螺钉	Torx	径向调节螺钉	六角	轴向调整螺钉	安装螺钉	六角	垫片
20	MS1933	T7	KUAM34	1.5 mm	KUAM35	MS2173	2 mm	CSWM 035 040
25	MS1153	T7	KUAM34	1.5 mm	KUAM20	MS2175	2.5 mm	CSWM 040 050
40	MS1155	T15	KUAM28	2 mm	KUAM30	191.405	4 mm	CSWM 060 050

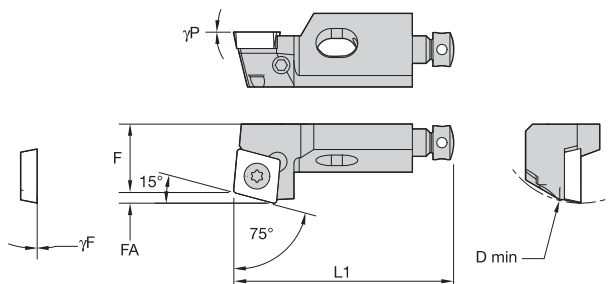
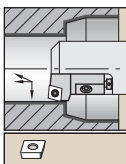

### ■ SCRP 75°

订货号	目录编号	D min	F	L1	FA	$\gamma_F^\circ$	$\gamma_P^\circ$	刀片
右手								
1098555	SCRPR08CA06	25	10,0	32	1,5	0.0	0.0	CP..060204/CP..2151

注: ANSI/ISO 兼容 60° 埋头孔加工刀片。  
 这款刀具还可应用 CPGM/CPGT/CPGW-21.5\_ 刀片。

### ■ 配件



D min	刀片螺钉	Torx	径向调节螺钉	六角	轴向调整螺钉	安装螺钉	六角	垫片
25	MS1153	T7	KUAM34	1.5 mm	KUAM20	MS2175	2.5 mm	CSWM 040 050

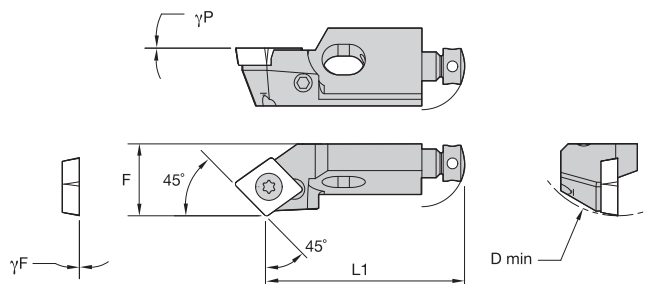
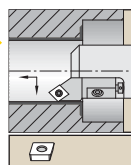

■ SCSP 45°

订货号	目录编号	D min	F	L1	$\gamma F^\circ$	$\gamma P^\circ$	刀片
右手							
1098328	SCSPR06CA05	20	8,0	21	0.0	0.0	CP..050204/CP..18151
1086536	SCSPR08CA06	25	10,0	28	0.0	0.0	CP..060204/CP..2151
左手							
1098548	SCSPL06CA05	20	8,0	21	0.0	0.0	CP..050204/CP..18151
1098549	SCSPL08CA06	25	10,0	28	0.0	0.0	CP..060204/CP..2151

注: ANSI/ISO 兼容 60° 埋头孔加工刀片。  
这款刀具还可应用 CPGM/CPGT/CPGW-21.5\_ 刀片。

■ 配件



D min	刀片螺钉	Torx	径向调节螺钉	六角	轴向调整螺钉	安装螺钉	六角	垫片
20	MS1933	T7	—	—	KUAM35	MS2173	2 mm	CSWM 035 040
25	MS1153	T7	KUAM34	1.5 mm	KUAM20	MS2175	2.5 mm	CSWM 040 050

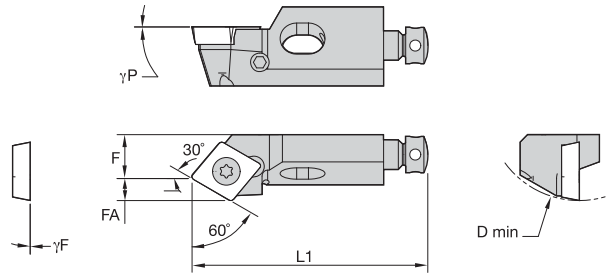

### ■ SCTP 60°

订货号	目录编号	D min	F	L1	FA	$\gamma F^\circ$	$\gamma P^\circ$	刀片
右手								
1098556	SCTPR06CA05	20	5,5	25	2,6	0.0	0.0	CP..050204/CP..18151
1098557	SCTPR08CA06	25	6,0	32	3,0	0.0	0.0	CP..060204/CP..2151
左手								
1098736	SCTPL08CA06	25	6,0	32	3,0	0.0	0.0	CP..060204/CP..2151

注: ANSI/ISO 兼容 60° 埋头孔加工刀片。  
 这款刀具还可应用 CPGM/CPGT/CPGW-21.5\_ 刀片。

### ■ 配件



D min	刀片螺钉	Torx	径向调节螺钉	六角	轴向调整螺钉	安装螺钉	六角	垫片
20	MS1933	T7	—	—	KUAM35	MS2173	2 mm	CSWM 035 040
25	MS1153	T7	KUAM34	1.5 mm	KUAM20	MS2175	2.5 mm	CSWM 040 050



● 首选  
○ 备选

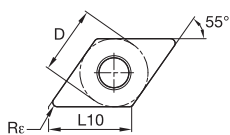
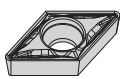

■ DCMT-FP

目录编号	D	L10	Rε	KCP05	KCP10B	KCP10	KCP25B	KCP25	KCP30	KCP40	KCK05B	KCK05	KCK15B	KCK15	KCK20B	KCK20	KCM15B	KCM15	KCM25B	KCM25	KCM35	KU10	K313	K68	KCS10	KCU10	KCU25	KC5010	KC5025	KC5410	KT315	KTP10	
DCMT070202FP	6,35	7,75	0,2	-	-	-	●	-	-	-	-	-	-	-	-	-	-	-	-	-	-	-	-	-	-	-	-	-	-	-	-	-	
DCMT070204FP	6,35	7,75	0,4	-	-	●	-	-	-	-	-	-	-	-	-	-	-	-	-	-	-	-	-	-	-	-	-	-	-	-	-	-	
DCMT070208FP	6,35	7,75	0,8	●	-	-	-	-	-	-	-	-	-	-	-	-	-	-	-	-	-	-	-	-	-	-	-	-	-	-	-	-	
DCMT11T302FP	9,53	11,63	0,2	-	●	-	●	●	-	-	-	-	-	-	-	-	-	-	-	-	-	-	-	-	-	-	-	-	-	-	-	-	
DCMT11T304FP	9,53	11,63	0,4	●	●	●	●	●	-	-	-	-	-	-	-	-	-	-	-	-	-	-	-	-	-	-	-	-	-	-	-	-	-
DCMT11T308FP	9,53	11,63	0,8	●	●	●	-	-	-	-	-	-	-	-	●	-	-	-	-	-	-	-	-	-	-	-	-	-	-	-	-	-	-
DCMT11T312FP	9,53	11,63	1,2	-	-	●	-	-	-	-	-	-	-	-	-	-	-	-	-	-	-	-	-	-	-	-	-	-	-	-	-	-	-
DCMT150404FP	12,70	15,50	0,4	-	-	●	-	-	-	-	-	-	-	-	-	-	-	-	-	-	-	-	-	-	-	-	-	-	-	-	-	-	-
DCMT150408FP	12,70	15,50	0,8	●	-	-	-	●	-	-	-	-	-	-	-	-	-	-	-	-	-	-	-	-	-	-	-	-	-	-	-	-	-

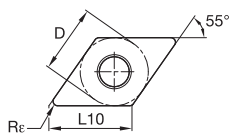
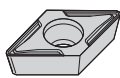

■ DCMT-FW

目录编号	D	L10	Rε	KCP05	KCP10B	KCP10	KCP25B	KCP25	KCP30	KCP40	KCK05B	KCK05	KCK15B	KCK15	KCK20B	KCK20	KCM15B	KCM15	KCM25B	KCM25	KCM35	KU10	K313	K68	KCS10	KCU10	KCU25	KC5010	KC5025	KC5410	KT315	KTP10	
DCMT11T304FW	9,53	11,63	0,2	-	-	-	-	●	-	-	-	-	-	-	-	●	-	-	-	-	-	-	-	-	-	-	-	-	-	-	-	-	-
DCMT11T308FW	9,53	11,63	0,8	-	-	-	-	●	-	-	-	-	-	-	-	-	-	-	-	-	-	-	-	-	-	-	-	-	-	-	-	-	-

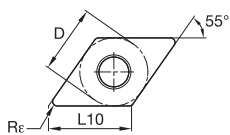
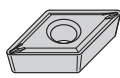

■ DCMT-LF

目录编号	D	L10	Rε	KCP05	KCP10B	KCP10	KCP25B	KCP25	KCP30	KCP40	KCK05B	KCK05	KCK15B	KCK15	KCK20B	KCK20	KCM15B	KCM15	KCM25B	KCM25	KCM35	KU10	K313	K68	KCS10	KCU10	KCU25	KC5010	KC5025	KC5410	KT315	KTP10	
DCMT070202LF	6,35	7,75	0,2	-	-	-	-	-	-	-	-	-	-	-	-	-	-	-	-	-	-	-	-	-	-	-	-	-	-	-	-	-	
DCMT070204LF	6,35	7,75	0,4	-	●	-	●	-	-	-	-	-	-	-	-	-	-	-	-	-	-	-	-	-	-	-	-	-	-	-	-	-	-
DCMT11T302LF	9,53	11,63	0,2	-	-	-	-	-	-	-	-	-	-	-	-	-	-	-	-	-	-	-	-	-	-	-	-	-	-	-	-	-	-
DCMT11T304LF	9,53	11,63	0,4	●	●	●	●	●	-	-	-	-	-	-	-	-	-	-	-	-	-	-	-	-	-	-	-	-	-	-	-	-	-
DCMT11T308LF	9,53	11,63	0,8	-	●	●	●	●	-	-	-	-	-	-	●	-	-	-	-	-	-	-	-	-	-	-	-	-	-	-	-	-	-
DCMT11T312LF	9,53	11,63	1,2	-	●	●	●	●	-	-	-	-	-	-	-	-	-	-	-	-	-	-	-	-	-	-	-	-	-	-	-	-	-
DCMT150404LF	12,70	15,50	0,4	-	-	●	-	-	-	-	-	-	-	-	-	-	-	-	-	-	-	-	-	-	-	-	-	-	-	-	-	-	-
DCMT150408LF	12,70	15,50	0,8	-	●	●	●	●	-	-	-	-	-	-	-	-	-	-	-	-	-	-	-	-	-	-	-	-	-	-	-	-	-





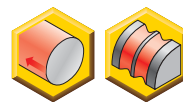
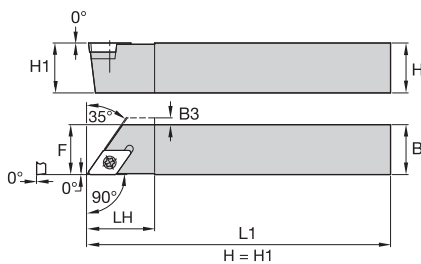
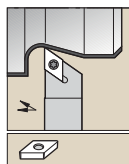

**SDAC 90°**

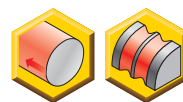
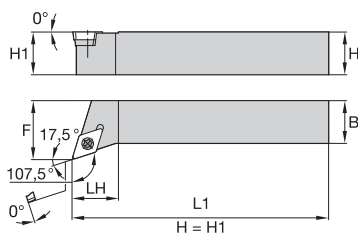
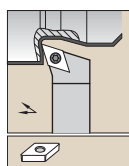
订货号	目录编号	H	B	F	L1	LH	B3	刀片	垫片	垫片螺钉	六角	刀片螺钉	Torx
右手													
1772159	SDACR1212M11Q	12	12	12,0	150	22,0	1,5	DC..11T308	—	—	—	MS1155	T15
1097720	SDACR1616K11Q	16	16	16,0	125	22,0	—	DC..11T308	SKDP343	SRS3	3.5 mm	MS1156	T15
左手													
1772160	SDACL1212M11Q	12	12	12,0	150	22,0	1,5	DC..11T308	—	—	—	MS1155	T15

**SDHC 107,5°**

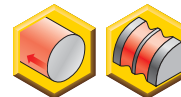
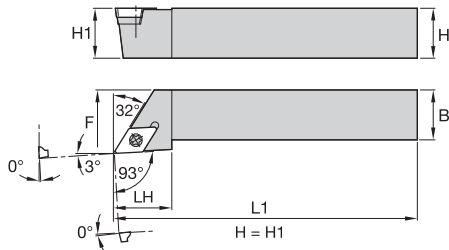
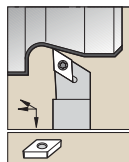
订货号	目录编号	H	B	F	L1	LH	刀片	垫片	垫片螺钉	六角	刀片螺钉	Torx
右手												
1097841	SDHCR1616H11	16	16	20,0	100	20,0	DC..11T308	SKDP343	SRS3	3.5 mm	MS1156	T15
1097989	SDHCR2020K11	20	20	25,0	125	20,0	DC..11T308	SKDP343	SRS3	3.5 mm	MS1156	T15
1130381	SDHCR2525M11	25	25	32,0	150	20,0	DC..11T308	SKDP343	SRS3	3.5 mm	MS1156	T15
1097843	SDHCR2525M15	25	25	32,0	150	25,0	DC..150408	SKDP453	SRS4	4 mm	MS1158	T15
左手												
1097986	SDHCL1616H11	16	16	20,0	100	20,0	DC..11T308	SKDP343	SRS3	3.5 mm	MS1156	T15
1097930	SDHCL2020K11	20	20	25,0	125	20,0	DC..11T308	SKDP343	SRS3	3.5 mm	MS1156	T15
1124630	SDHCL2525M11	25	25	32,0	150	20,0	DC..11T308	SKDP343	SRS3	3.5 mm	MS1156	T15
1097988	SDHCL2525M15	25	25	32,0	150	25,0	DC..150408	SKDP453	SRS4	4 mm	MS1158	T15



■ SDJC 93°

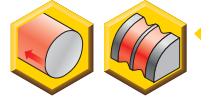
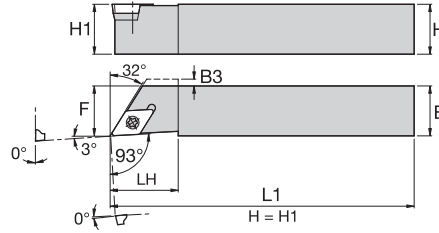
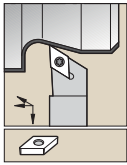

订货号	目录编号	H	B	F	L1	LH	刀片	垫片	垫片螺钉	六角	刀片螺钉	Torx
右手												
1097847	SDJCR0808L07	8	8	10,0	140	16,0	DC..070204	—	—	—	MS1153	T7
1097848	SDJCR1010M07	10	10	12,0	150	16,0	DC..070204	—	—	—	MS1153	T7
1097849	SDJCR1212N07	12	12	16,0	160	16,0	DC..070204	—	—	—	MS1153	T7
1097850	SDJCR1212N11	12	12	16,0	160	22,0	DC..11T308	—	—	—	MS1155	T15
1244972	SDJCR1616H07	16	16	20,0	100	16,0	DC..070204	—	—	—	MS1153	T7
1097851	SDJCR1616H11	16	16	20,0	100	22,0	DC..11T308	SKDP343	SRS3	3.5 mm	MS1156	T15
1244974	SDJCR2020K07	20	20	25,0	125	16,0	DC..070204	—	—	—	MS1153	T7
1097853	SDJCR2020K11	20	20	25,0	125	22,0	DC..11T308	SKDP343	SRS3	3.5 mm	MS1156	T15
1097852	SDJCR2020K15	20	20	25,0	125	32,0	DC..150408	SKDP453	SRS4	4 mm	MS1158	T15
1097854	SDJCR2525M11	25	25	32,0	150	22,0	DC..11T308	SKDP343	SRS3	3.5 mm	MS1156	T15
1097855	SDJCR2525M15	25	25	32,0	150	32,0	DC..150408	SKDP453	SRS4	4 mm	MS1158	T15
左手												
1097997	SDJCL0808L07	8	8	10,0	140	16,0	DC..070204	—	—	—	MS1153	T7
1097998	SDJCL1010M07	10	10	12,0	150	16,0	DC..070204	—	—	—	MS1153	T7
1097999	SDJCL1212N07	12	12	16,0	160	16,0	DC..070204	—	—	—	MS1153	T7
1098000	SDJCL1212N11	12	12	16,0	160	22,0	DC..11T308	—	—	—	MS1155	T15
1244966	SDJCL1616H07	16	16	20,0	100	16,0	DC..070204	—	—	—	MS1153	T7
1098001	SDJCL1616H11	16	16	20,0	100	22,0	DC..11T308	SKDP343	SRS3	3.5 mm	MS1156	T15
1244968	SDJCL2020K07	20	20	25,0	125	16,0	DC..070204	—	—	—	MS1153	T7
1098003	SDJCL2020K11	20	20	25,0	125	22,0	DC..11T308	SKDP343	SRS3	3.5 mm	MS1156	T15
1192473	SDJCL2525M11	25	25	32,0	150	22,0	DC..11T308	SKDP343	SRS3	3.5 mm	MS1156	T15
1098004	SDJCL2525M15	25	25	32,0	150	32,0	DC..150408	SKDP453	SRS4	4 mm	MS1158	T15

**SDJC-F 93°**

订货号	目录编号	H	B	F	L1	LH	B3	刀片	垫片	垫片螺钉	六角	刀片螺钉	Torx
<b>右手</b>													
1772157	SDJCRF0808M07Q	8	8	8,0	150	16,0	1,5	DC..070204	—	—	—	MS1153	T7
1097844	SDJCRF1010M07Q	10	10	10,0	150	16,0	—	DC..070204	—	—	—	MS1153	T7
1097845	SDJCRF1212M07Q	12	12	12,0	150	16,0	—	DC..070204	—	—	—	MS1153	T7
1097846	SDJCRF1616K11Q	16	16	16,0	125	22,0	—	DC..11T308	SKDP343	SRS3	3.5 mm	MS1156	T15
<b>左手</b>													
1097996	SDJCLF1616K11Q	16	16	16,0	125	22,0	—	DC..11T308	SKDP343	SRS3	3.5 mm	MS1156	T15

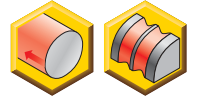
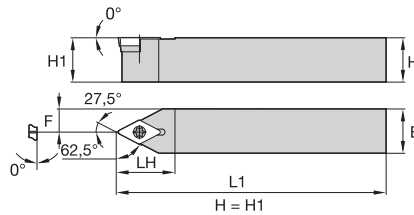
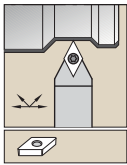
**SDNC 62,5°**

订货号	目录编号	H	B	F	L1	LH	刀片	垫片	垫片螺钉	六角	刀片螺钉	Torx
<b>左手</b>												
1097856	SDNCN0808L07	8	8	4,0	140	16,0	DC..070204	—	—	—	MS1153	T7
1097857	SDNCN1010M07	10	10	5,0	150	16,0	DC..070204	—	—	—	MS1153	T7
1097858	SDNCN1212N07	12	12	6,0	160	16,0	DC..070204	—	—	—	MS1153	T7
1097859	SDNCN1616H11	16	16	8,0	100	22,0	DC..11T308	SKDP343	SRS3	3.5 mm	MS1156	T15
1097861	SDNCN2020K11	20	20	10,0	125	22,0	DC..11T308	SKDP343	SRS3	3.5 mm	MS1156	T15
1097860	SDNCN2020K15	20	20	10,0	125	28,0	DC..150408	SKDP453	SRS4	4 mm	MS1158	T15
1097862	SDNCN2525M15	25	25	12,5	150	28,0	DC..150408	SKDP453	SRS4	4 mm	MS1158	T15

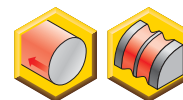
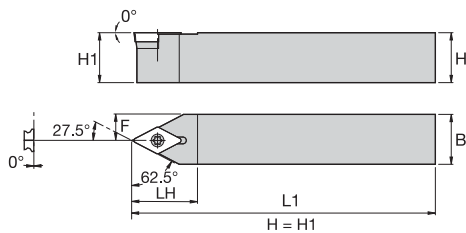
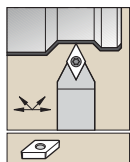

■ SDPC 62,5°



订货号	目录编号	H	B	F	L1	LH	刀片	刀片螺钉	Torx
1772173	SDPCN1212M11Q	12	12	6,0	150	22,0	DC..11T308	MS1155	T15

螺纹接口镗杆

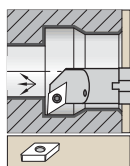

带内冷功能的钢质刀柄。

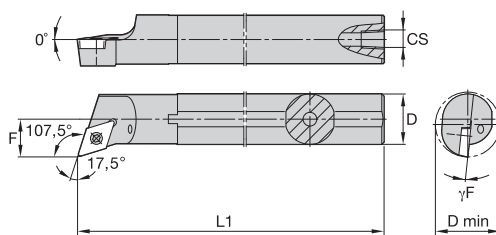

■ A-SDQC 107,5°

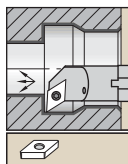
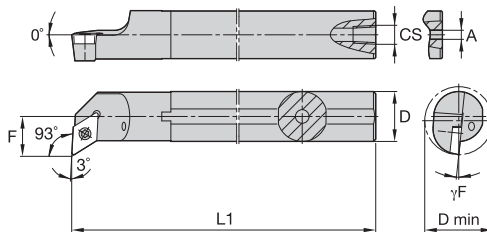

订货号	目录编号	D	D min	F	L1	CS	γF°	刀片	刀片螺钉	Torx
右手										
1098188	A12MSDQCR07	12	16,0	9,0	150	1/16-27 NPT	-6,0	DC..070204	MS1153	T7
1098198	A16RSDQCR07	16	20,0	11,0	200	1/8-27 NPT	-5,0	DC..070204	MS1153	T7
1098147	A20SSDQCR11	20	25,0	13,0	250	1/8-27 NPT	-5,0	DC..11T308	MS1155	T15
1098260	A25TSDQCR11	25	32,0	17,0	300	1/4-18 NPT	-4,0	DC..11T308	MS1155	T15
左手										
1098193	A12MSDQCL07	12	16,0	9,0	150	1/16-27 NPT	-6,0	DC..070204	MS1153	T7
1098203	A16RSDQCL07	16	20,0	11,0	200	1/8-27 NPT	-5,0	DC..070204	MS1153	T7
1098149	A20SSDQCL11	20	25,0	13,0	250	1/8-27 NPT	-5,0	DC..11T308	MS1155	T15
1098264	A25TSDQCL11	25	32,0	17,0	300	1/4-18 NPT	-4,0	DC..11T308	MS1155	T15

 带内冷功能的  
 钢刀柄。

**A-SDUC 93°**

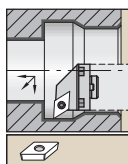
订货号	目录编号	D	D min	F	L1	A	CS	γF°	刀片	垫片	垫片螺钉	六角	刀片螺钉	Torx
<b>右手</b>														
1886506	A10KSDUCR07	10	13,0	7,0	125	3,2	—	-7.0	DC..070204	—	—	—	MS1153	T7
1098187	A12MSDUCR07	12	16,0	9,0	150	—	1/16-27 NPT	-4.0	DC..070204	—	—	—	MS1153	T7
1098197	A16RSDUCR07	16	20,0	11,0	200	—	1/8-27 NPT	-4.0	DC..070204	—	—	—	MS1153	T7
1886508	A16RSDUCR11	16	20,0	11,0	200	—	1/8-27 NPT	-6.0	DC..11T308	—	—	—	MS1155	T15
1098146	A20SSDUCR11	20	25,0	13,0	250	—	1/8-27 NPT	-5.0	DC..11T308	—	—	—	MS1155	T15
1098259	A25TSDUCR11	25	32,0	17,0	300	—	1/4-18 NPT	-4.0	DC..11T308	—	—	—	MS1155	T15
1098283	A32TSDUCR15	32	40,0	22,0	300	—	1/4-18 NPT	-7.0	DC..150408	SKDP453	SRS4	4 mm	MS1158	T15
<b>左手</b>														
1886505	A10KSDUCL07	10	13,0	7,0	125	3,2	—	-7.0	DC..070204	—	—	—	MS1153	T7
1098192	A12MSDUCL07	12	16,0	9,0	150	—	1/16-27 NPT	-4.0	DC..070204	—	—	—	MS1153	T7
1098202	A16RSDUCL07	16	20,0	11,0	200	—	1/8-27 NPT	-4.0	DC..070204	—	—	—	MS1153	T7
1886507	A16RSDUCL11	16	20,0	11,0	200	—	1/8-27 NPT	-6.0	DC..11T308	—	—	—	MS1155	T15
1098148	A20SSDUCL11	20	25,0	13,0	250	—	1/8-27 NPT	-5.0	DC..11T308	—	—	—	MS1155	T15
1098263	A25TSDUCL11	25	32,0	17,0	300	—	1/4-18 NPT	-4.0	DC..11T308	—	—	—	MS1155	T15
1098284	A32TSDUCL15	32	40,0	22,0	300	—	1/4-18 NPT	-7.0	DC..150408	SKDP453	SRS4	4 mm	MS1158	T15

**螺纹接口镗头**

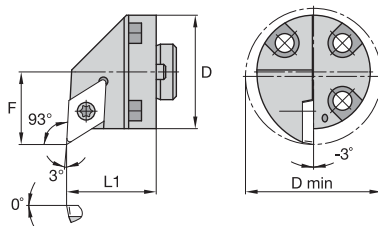
带有内冷。

**H-SDUC 93°**



订货号	目录编号	D	D min	F	L1	刀片	刀片螺钉	Torx
<b>右手</b>								
1772255	H25SDUCR11	25	32,0	17,0	20	DC..11T308	MS1155	T15
1772257	H32SDUCR11	32	40,0	22,0	25	DC..11T308	MS1155	T15
3612136	H40SDUCR11	40	50,0	27,0	41	DC..11T308	MS1156	T15
3612138	H50SDUCR11	50	63,0	35,0	41	DC..11T308	MS1156	T15
<b>左手</b>								
1772256	H25SDUCL11	25	32,0	17,0	20	DC..11T308	MS1155	T15
1772258	H32SDUCL11	32	40,0	22,0	25	DC..11T308	MS1155	T15
3612139	H50SDUCL11	50	63,0	35,0	41	DC..11T308	MS1156	T15







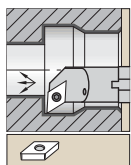

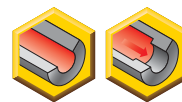
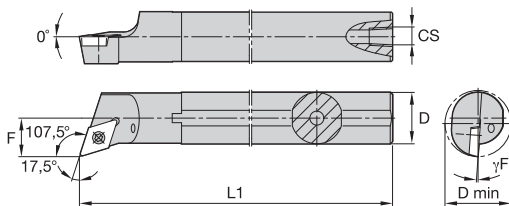

带内冷功能的钢质刀柄。

**■ A-SDQP 107,5°**

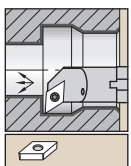

订货号	目录编号	D	D min	F	L1	CS	γF°	刀片	刀片螺钉	Torx
右手										
1098186	A12MSDQPR07	12	16,0	9,0	150	1/16-27 NPT	-2.0	DP..070204	MS1153	T7
1098196	A16RSDQPR07	16	20,0	11,0	200	1/8-27 NPT	0.0	DP..070204	MS1153	T7
1098247	A20SSDQPR11	20	25,0	13,0	250	1/8-27 NPT	-2.0	DP..11T308	MS1155	T15
1098258	A25TSDQPR11	25	32,0	17,0	300	1/4-18 NPT	0.0	DP..11T308	MS1155	T15
左手										
1098191	A12MSDQPL07	12	16,0	9,0	150	1/16-27 NPT	-2.0	DP..070204	MS1153	T7
1098201	A16RSDQPL07	16	20,0	11,0	200	1/8-27 NPT	0.0	DP..070204	MS1153	T7
1098252	A20SSDQPL11	20	25,0	13,0	250	1/8-27 NPT	-2.0	DP..11T308	MS1155	T15
1098262	A25TSDQPL11	25	32,0	17,0	300	1/4-18 NPT	0.0	DP..11T308	MS1155	T15

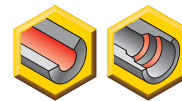
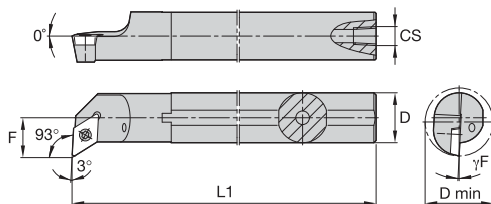

带内冷功能的钢质刀柄。

**■ A-SDUP 93°**

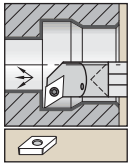
订货号	目录编号	D	D min	F	L1	CS	γF°	刀片	刀片螺钉	Torx
右手										
1098184	A12MSDUPR07	12	16,0	9,0	150	1/16-27 NPT	-2.0	DP..070204	MS1153	T7
1098194	A16RSDUPR07	16	20,0	11,0	200	1/8-27 NPT	0.0	DP..070204	MS1153	T7
1098245	A20SSDUPR11	20	25,0	13,0	250	1/8-27 NPT	-2.0	DP..11T308	MS1155	T15
1098257	A25TSDUPR11	25	32,0	17,0	300	1/4-18 NPT	0.0	DP..11T308	MS1155	T15
左手										
1098189	A12MSDUPL07	12	16,0	9,0	150	1/16-27 NPT	-2.0	DP..070204	MS1153	T7
1098199	A16RSDUPL07	16	20,0	11,0	200	1/8-27 NPT	0.0	DP..070204	MS1153	T7
1098250	A20SSDUPL11	20	25,0	13,0	250	1/8-27 NPT	-2.0	DP..11T308	MS1155	T15



硬质合金刀柄（带内冷功能）。

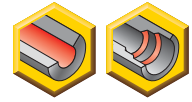
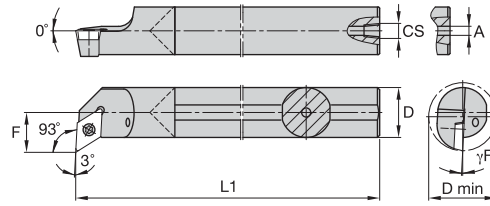

■ E-SDUP 93°



订货号	目录编号	D	D min	F	L1	A	γF°	刀片	刀片螺钉	Torx
右手										
1152892	E12QSDUPR07	12	16,0	9,0	180	4,8	-2,0	DP..070204	MS1153	T7
1152894	E16RSDUPR07	16	20,0	11,0	200	5,5	0,0	DP..070204	MS1153	T7
1152906	E20SSDUPR11	20	25,0	13,0	250	7,1	-2,0	DP..11T308	MS1155	T15
左手										
1152893	E12QSDUPL07	12	16,0	9,0	180	4,8	-2,0	DP..070204	MS1153	T7
1152895	E16RSDUPL07	16	20,0	11,0	200	5,5	0,0	DP..070204	MS1153	T7
1152907	E20SSDUPL11	20	25,0	13,0	250	7,1	-2,0	DP..11T308	MS1155	T15

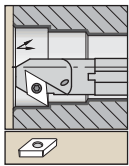

硬质合金刀柄（带内冷功能）。

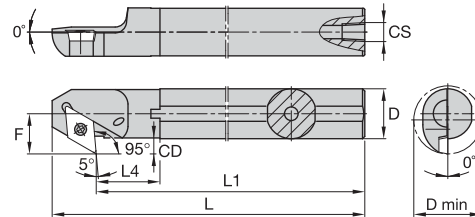

■ A-SDXP 95°



订货号	目录编号	D	D min	F	L1	L	L4	CD	CS	刀片	刀片螺钉	Torx
右手												
1098185	A12MSDXPR07	12	16,0	9,0	150	162,0	—	3,09	1/16-27 NPT	DP..070204	MS1153	T7
1098195	A16RSDXPR07	16	20,0	11,0	200	212,0	—	3,20	1/8-27 NPT	DP..070204	MS1153	T7
1098246	A20SSDXPR11	20	25,0	13,0	250	270,0	48,44	4,31	1/8-27 NPT	DP..11T308	MS1155	T15
左手												
1098190	A12MSDXPL07	12	16,0	9,0	150	162,0	—	3,09	1/16-27 NPT	DP..070204	MS1153	T7
1098200	A16RSDXPL07	16	20,0	11,0	200	212,0	—	3,20	1/8-27 NPT	DP..070204	MS1153	T7
1098251	A20SSDXPL11	20	25,0	13,0	250	270,0	48,44	4,31	1/8-27 NPT	DP..11T308	MS1155	T15

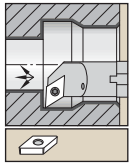

重金属镗杆，带内冷功能。

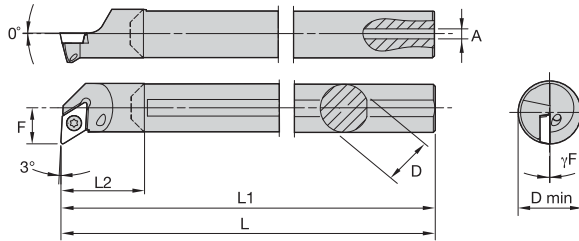

ISO 车削刀具

## ■ L-SDUP 93°



订货号	目录编号	D	D min	F	L1	L	L2	A	γF°	刀片	刀片螺钉	Torx
右手												
3331116	L12QSDUPR07	12	16,0	9,0	181	181,2	22,4	4,0	-2,0	DP..070204..	MS1153	T7
3331117	L20SSDUPR11	20	25,0	13,0	251	251,5	33,6	4,0	-2,0	DP..11T308..	MS1155	T15
左手												
3331121	L12QSDUPL07	12	16,0	9,0	181	181,2	22,4	4,0	-2,0	DP..070204..	MS1153	T7

ISO 车削刀具

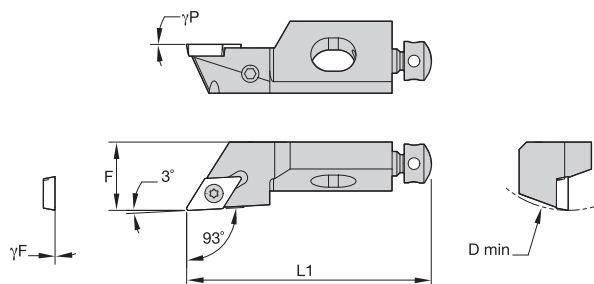
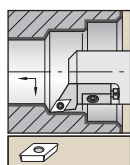

■ SDJP 93°

订货号	目录编号	D min	F	L1	$\gamma F^\circ$	$\gamma P^\circ$	刀片
右手 1098757	SDJPR10CA07	40	14,0	50	0.0	0.0	DP..070204/DP..2151
左手 1098758	SDJPL10CA07	40	14,0	50	0.0	0.0	DP..070204/DP..2151

■ 配件



D min	刀片螺钉	Torx	径向调节螺钉	六角	轴向调整螺钉	安装螺钉	六角	垫片
40	MS1153	T7	KUAM28	2 mm	KUAM30	191.405	4 mm	CSWM 060 050

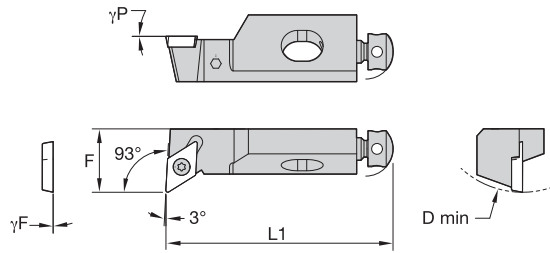
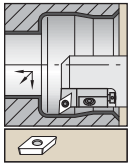

### ■ SDUP 93°

订货号	目录编号	D min	F	L1	γF°	γP°	刀片
右手 1098728	SDUPR10CA07	40	14,0	50	0.0	0.0	DP..070204/DP..2151

### ■ 配件



D min	刀片螺钉	Torx	径向调节螺钉	六角	轴向调节螺钉	安装螺钉	六角	垫片
40	MS1153	T7	KUAM28	2 mm	KUAM30	191.405	4 mm	CSWM 060 050









● 首选  
○ 备选

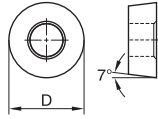
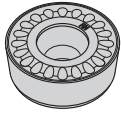

■ RCMT-RH

目录编号	D	L10	Rε
RCMT2006M0RH	20,00	-	-

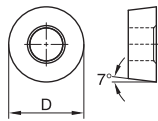
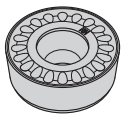

■ RCMX-RH

目录编号	D	L10	Rε
RCMX2507M0RH	25,00	-	-
RCMX3209M0RH	32,00	-	-

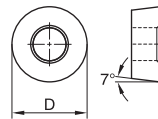
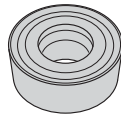

■ RCMT-RM

目录编号	D	L10	Rε
RCMT2006M0RM	20,00	-	-

P	M	K	N	S	H	KCP05	KCP10B	KCP10	KCP25B	KCP25	KCP30	KCP40	KCK05B	KCK05	KCK15B	KCK15	KCK20B	KCK20	KCM15B	KCM15	KCM25B	KCM25	KCM35	KU10	K313	K68	KCS10	KCU10	KCU25	KC5010	KC5025	KC5410	KT315	KTP10		
●	●	○	○	○	○	-	-	●	-	●	-	-	-	-	-	-	-	-	-	●	●	●	●	●	●	●	●	●	●	●	●	●	●	●	●	●
○	○	○	○	○	○	-	-	-	-	-	-	-	-	-	-	-	-	-	-	-	-	-	-	-	-	-	-	-	-	-	-	-	-	-	-	-



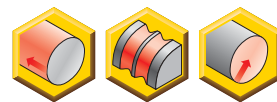
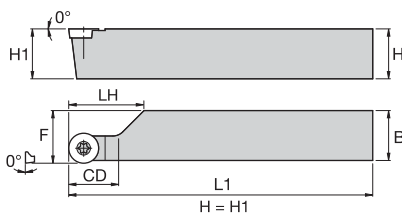
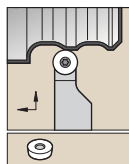

### SRAC



订货号	目录编号	H	B	F	L1	LH	CD	刀片	刀片螺钉	Torx
右手										
1097887	SRACR1212N08	12	12	13,0	160	31,0	12,0	RC..0803M0	MS1154	T9
1097888	SRACR1616Q08	16	16	17,0	180	35,0	16,0	RC..0803M0	MS1154	T9

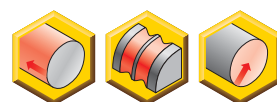
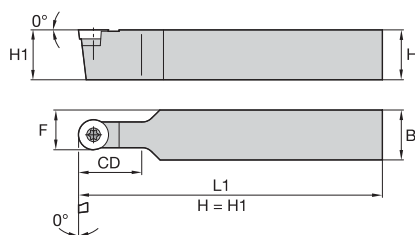
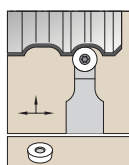

### SRDC



订货号	目录编号	H	B	F	L1	CD	刀片	垫片	垫片螺钉	六角	刀片螺钉	Torx
1097892	SRDCN1212N06	12	12	9,0	160	12,0	RC..0602M0	—	—	—	MS1153	T7
1097891	SRDCN1212N08	12	12	10,0	160	12,0	RC..0803M0	—	—	—	MS1154	T9
1097899	SRDCN1616H06	16	16	11,0	100	16,0	RC..0602M0	—	—	—	MS1153	T7
1097897	SRDCN1616H08	16	16	12,0	100	16,0	RC..0803M0	—	—	—	MS1154	T9
1097898	SRDCN1616H10	16	16	13,0	100	16,0	RC..10T3M0	SKRN100300	SRS3	3.5 mm	MS1156	T15
1097893	SRDCN1616Q08	16	16	12,0	180	16,0	RC..0803M0	—	—	—	MS1154	T9
1097900	SRDCN2020K08	20	20	14,0	125	20,0	RC..0803M0	—	—	—	MS1154	T9
1097901	SRDCN2020K10	20	20	15,0	125	20,0	RC..10T3M0	SKRN100300	SRS3	3.5 mm	MS1156	T15
1097894	SRDCN2020K12	20	20	16,0	125	20,0	RC..1204M0	SKRN1203M0	SRS3	3.5 mm	MS1156	T15
1097903	SRDCN2525M08	25	25	16,5	150	25,0	RC..0803M0	—	—	—	MS1154	T9
1097902	SRDCN2525M10	25	25	17,5	150	25,0	RC..10T3M0	SKRN100300	SRS3	3.5 mm	MS1156	T15
1097895	SRDCN2525M12	25	25	18,5	150	25,0	RC..1204M0	SKRN1203M0	SRS3	3.5 mm	MS1156	T15
1097896	SRDCN2525M16	25	25	20,5	150	25,0	RC..1605M0	SKRN160400	SRS5	4 mm	MS1160	T15

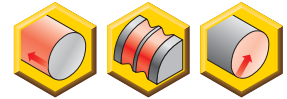
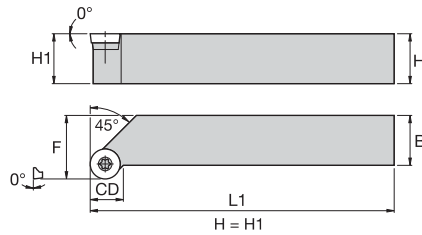
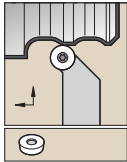

■ SRGC



订货号	目录编号	H	B	F	L1	CD	刀片	垫片	垫片螺钉	六角	刀片螺钉	Torx
右手												
1097792	SRGCR1616H06	16	16	20,0	100	7,0	RC..0602M0	—	—	—	MS1153	T7
1097791	SRGCR1616H10	16	16	20,0	100	7,9	RC..10T3M0	SKRN100300	SRS3	3.5 mm	MS1156	T15
1097793	SRGCR2020K08	20	20	25,0	125	9,0	RC..0803M0	—	—	—	MS1154	T9
1097794	SRGCR2020K10	20	20	25,0	125	9,3	RC..10T3M0	SKRN100300	SRS3	3.5 mm	MS1156	T15
1097796	SRGCR2525M08	25	25	32,0	150	11,8	RC..0803M0	—	—	—	MS1154	T9
1097795	SRGCR2525M10	25	25	32,0	150	12,1	RC..10T3M0	SKRN100300	SRS3	3.5 mm	MS1156	T15
1097788	SRGCR2525M12	25	25	32,0	150	12,7	RC..1204M0	SKRN1203M0	SRS3	3.5 mm	MS1156	T15
左手												
1097937	SRGCL1616H06	16	16	20,0	100	7,0	RC..0602M0	—	—	—	MS1153	T7
1097936	SRGCL1616H10	16	16	20,0	100	7,9	RC..10T3M0	SKRN100300	SRS3	3.5 mm	MS1156	T15
1097938	SRGCL2020K08	20	20	25,0	125	9,0	RC..0803M0	—	—	—	MS1154	T9
1097941	SRGCL2525M08	25	25	32,0	150	11,8	RC..0803M0	—	—	—	MS1154	T9
1097940	SRGCL2525M10	25	25	32,0	150	12,1	RC..10T3M0	SKRN100300	SRS3	3.5 mm	MS1156	T15
1097933	SRGCL2525M12	25	25	32,0	150	12,7	RC..1204M0	SKRN1203M0	SRS3	3.5 mm	MS1156	T15











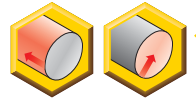
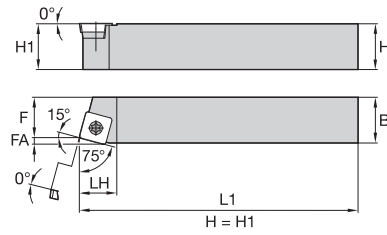
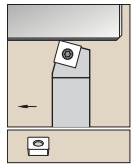

**SSBC 75°**

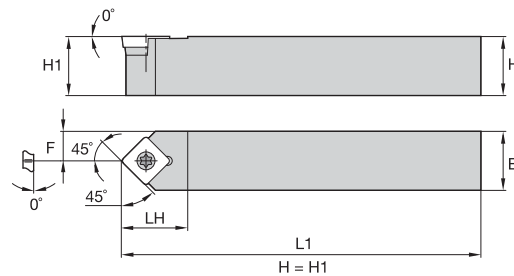
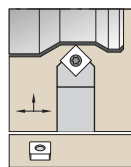
订货号	目录编号	H	B	F	L1	LH	FA	刀片	垫片	垫片螺钉	六角	刀片螺钉	Torx
右手													
1097863	SSBCR1212N09	12	12	11,0	160	16,0	2,2	SC..09T308	—	—	—	MS1155	T15
1097867	SSBCR2525M12	25	25	22,0	150	21,0	3,1	SC..120408	SKSP453	SRS4	4 mm	MS1158	T15
左手													
1098009	SSBCL1616H09	16	16	13,0	100	16,0	2,2	SC..09T308	SKSP343	SRS3	3.5 mm	MS1156	T15

**SSDC 45°**

订货号	目录编号	H	B	F	L1	LH	刀片	垫片	垫片螺钉	六角	刀片螺钉	Torx
1098005	SSDCN1212N09	12	12	6,0	160	18,0	SC..09T308	—	—	—	MS1155	T15
1098006	SSDCN1616H09	16	16	8,0	100	18,0	SC..09T308	SKSP343	SRS3	3.5 mm	MS1156	T15
1098007	SSDCN2020K09	20	20	10,0	125	18,0	SC..09T308	SKSP343	SRS3	3.5 mm	MS1156	T15

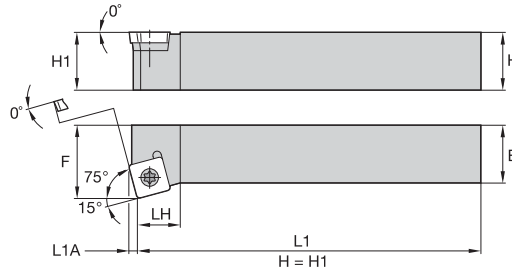
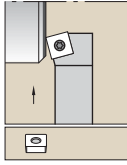
ISO 车削刀具



■ SSKC 75°



订货号	目录编号	H	B	F	L1	LH	L1A	刀片	垫片	垫片螺钉	六角	刀片螺钉	Torx
右手													
1097882	SSKCR1616H09	16	16	20,0	100	16,0	2,2	SC..09T308	SKSP343	SRS3	3.5 mm	MS1156	T15
左手													
1098027	SSKCL2020K12	20	20	25,0	125	22,0	3,1	SC..120408	SKSP453	SRS4	4 mm	MS1158	T15

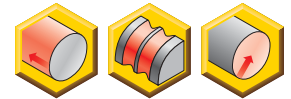
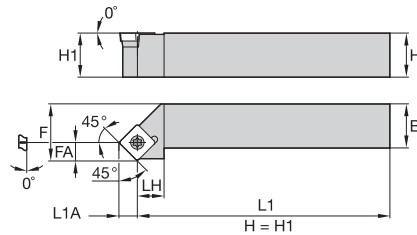
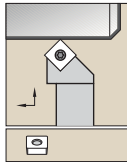

■ SSSC 45°



订货号	目录编号	H	B	F	L1	LH	FA	L1A	刀片	垫片	垫片螺钉	六角	刀片螺钉	Torx
右手														
1097808	SSSCR1212N09	12	12	16,0	160	18,0	5,8	6,1	SC..09T308	—	—	—	MS1155	T15
1097809	SSSCR1616H09	16	16	20,0	100	18,0	6,1	6,1	SC..09T308	SKSP343	SRS3	3.5 mm	MS1156	T15
1097811	SSSCR1616H12	16	16	20,0	100	25,0	8,3	8,3	SC..120408	SKSP453	SRS4	4 mm	MS1158	T15
1097810	SSSCR2020K12	20	20	25,0	125	25,0	8,1	8,3	SC..120408	SKSP453	SRS4	4 mm	MS1158	T15
1244982	SSSCR2525M12	25	25	32,0	150	25,0	8,1	8,3	SC..120408	SKSP453	SRS4	4 mm	MS1158	T15
左手														
1097953	SSSCL1212N09	12	12	16,0	160	18,0	5,8	6,1	SC..09T308	—	—	—	MS1155	T15
1097954	SSSCL1616H09	16	16	20,0	100	18,0	5,8	6,1	SC..09T308	SKSP343	SRS3	3.5 mm	MS1156	T15
1097956	SSSCL1616H12	16	16	20,0	100	25,0	8,1	8,3	SC..120408	SKSP453	SRS4	4 mm	MS1158	T15
1097955	SSSCL2020K12	20	20	25,0	125	25,0	8,1	8,3	SC..120408	SKSP453	SRS4	4 mm	MS1158	T15
1514473	SSSCL2525M12	25	25	32,0	150	25,0	8,1	8,3	SC..120408	SKSP453	SRS4	4 mm	MS1158	T15

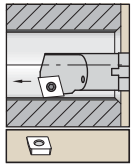

带有冷功能的钢质刀柄。

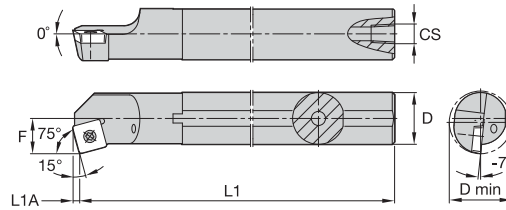

ISO 车削刀具

**A-SSKC 75°**

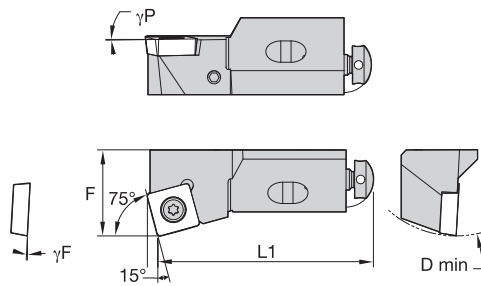
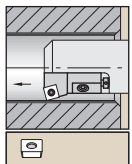

订货号	目录编号	D	D min	F	L1	L1A	CS	刀片	刀片螺钉	Torx
右手										
1886510	A16RSSKCR09	16	20,0	11,0	200	2,2	1/8-27 NPT	SC..09T308	MS1155	T15

**螺纹接口刀夹**

**SSKC 75°**

订货号	目录编号	D min	F	L1	γF°	γP°	刀片
右手							
1098719	SSKCR12CA12	50	20,0	55	-3.0	0.0	SC..120408/SC..432
1098720	SSKCR16CA12	60	25,0	63	-3.0	0.0	SC..120408/SC..432
左手							
1098721	SSKCL12CA12	50	20,0	55	-3.0	0.0	SC..120408/SC..432

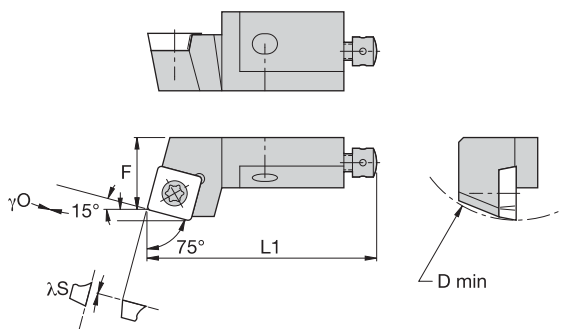
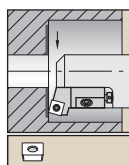
**配件**

D min	刀片螺钉	Torx	径向调节螺钉	六角	轴向调节螺钉	安装螺钉	六角	垫片
50	MS1157	T15	KUAM23	2.5 mm	KUAM31	191.406	4 mm	CSWM 060 050
60	MS1157	T15	KUAM25	2.5 mm	KUAM32	191.407	5 mm	CSWM 080 050



■ SSRC 75°

订货号	目录编号	D min	F	L1	λS°	γO°	刀片
右手 1098723	SSRCR12CA12	50	20,0	55	-3.0	0.0	SC..120408/SC..432
左手 1098725	SSRCL12CA12	50	20,0	55	-3.0	0.0	SC..120408/SC..432

■ 配件

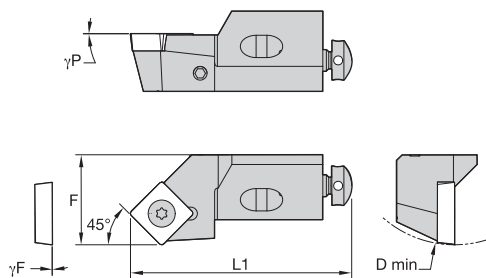
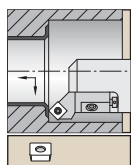

D min	刀片螺钉	Torx	径向调节螺钉	六角	轴向调整螺钉	安装螺钉	六角	垫片
50	MS1157	T15	KUAM23	2.5 mm	KUAM31	191.406	4 mm	CSWM 060 050

**SSSC 45°**

订货号	目录编号	D min	F	L1	γF°	γP°	刀片
右手 1098737	SSSCR12CA12	50	20,0	47	-3.0	0.0	SC..120408/SC..432
左手 1098739	SSSCL12CA12	50	20,0	47	-3.0	0.0	SC..120408/SC..432

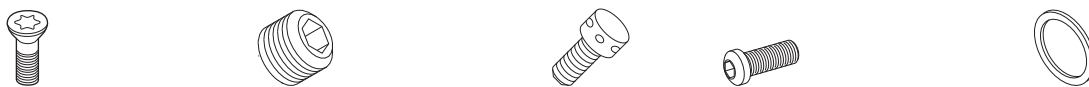
**配件**

D min	刀片螺钉	Torx	径向调节螺钉	六角	轴向调节螺钉	安装螺钉	六角	垫片
50	MS1157	T15	KUAM23	2.5 mm	KUAM31	191.406	4 mm	CSWM 060 050





ISO 车削刀具

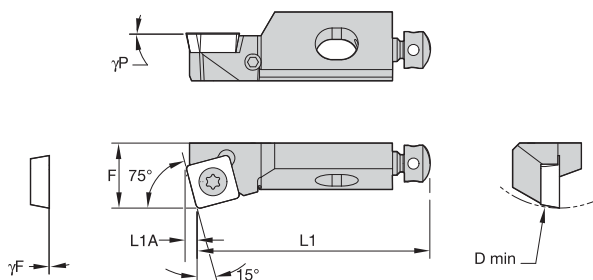
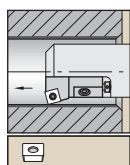

■ SSKP 75°

订货号	目录编号	D min	F	L1	$\lambda_S^\circ$	$\gamma_F^\circ$	$\gamma_P^\circ$	刀片
右手 1098570	SSKPR10CA09	40	14,0	50	0.0	0.0	0.0	SP..09T308/SP..3252

■ 配件



D min	刀片螺钉	Torx	径向调节螺钉	六角	轴向调整螺钉	安装螺钉	六角	垫片
40	MS1155	T15	KUAM28	2 mm	KUAM30	191.405	4 mm	CSWM 060 050



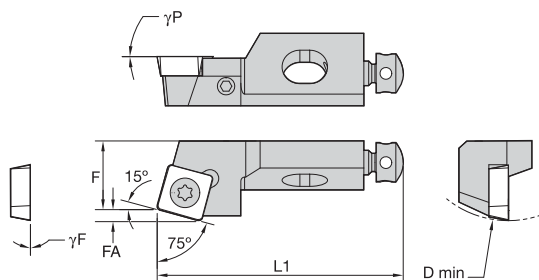
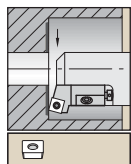

### ■ SSRP 75°

订货号	目录编号	D min	F	FA	L1	$\gamma_F^\circ$	$\gamma_P^\circ$	刀片
右手 1098574	SSRPR10CA09	40	14,0	2,2	50	0.0	0.0	SP..09T308/SP..3252

### ■ 配件



D min	刀片螺钉	Torx	径向调节螺钉	六角	轴向调整螺钉	安装螺钉	六角	垫片
40	MS1155	T15	KUAM28	2 mm	KUAM30	191.405	4 mm	CSWM 060 050

ISO 车削刀具

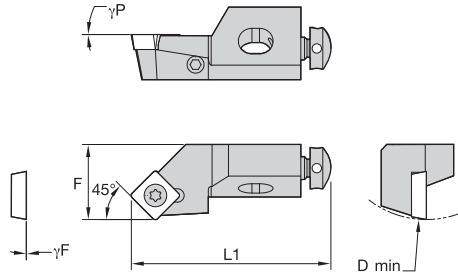
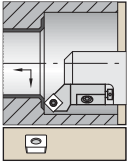

■ SSSP 45°

订货号	目录编号	D min	F	L1	γF°	γP°	刀片
右手 1098572	SSSPR10CA09	40	14,0	44	0.0	0.0	SP..09T308/SP..3252
左手 1098764	SSSPL10CA09	40	14,0	44	0.0	0.0	SP..09T308/SP..3252

■ 配件

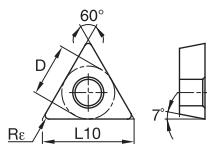
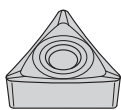

D min	刀片螺钉	Torx	径向调节螺钉	六角	轴向调整螺钉	安装螺钉	六角	垫片
40	MS1155	T15	KUAM28	2 mm	KUAM30	191.405	4 mm	CSWM 060 050

● 首选  
 ○ 备选

**TCGT-HP**

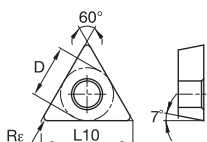
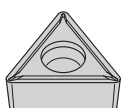
目录编号	D	L10	Re	KCP05	KCP10B	KCP10	KCP25B	KCP25	KCP30	KCP40	KCK05B	KCK05	KCK15B	KCK15	KCK20B	KCK20	KCM15B	KCM15	KCM25B	KCM25	KCM35	KU10	K313	K68	KCS10	KCU10	KCU25	KC5010	KC5025	KC5410	KT315	KTP10
TCGT110202HP	6,35	11,00	0,2	-	-	-	-	-	-	-	-	-	-	-	-	-	-	-	-	-	-	-	-	-	-	-	-	-	-	-	-	-
TCGT110204HP	6,35	11,00	0,4	-	-	-	-	-	-	-	-	-	-	-	-	-	-	-	-	-	-	-	●	-	-	-	-	-	-	-	-	-
TCGT110208HP	6,35	11,00	0,8	-	-	-	-	-	-	-	-	-	-	-	-	-	-	-	-	-	-	-	-	-	-	-	-	-	-	-	-	-
TCGT16T302HP	9,53	16,50	0,2	-	-	-	-	-	-	-	-	-	-	-	-	-	-	-	-	-	-	-	-	-	-	●	●	●	●	●	●	●
TCGT16T304HP	9,53	16,50	0,4	-	-	-	-	-	-	-	-	-	-	-	-	-	-	-	-	-	-	-	-	-	-	●	●	●	●	●	●	●
TCGT16T308HP	9,53	16,50	0,8	-	-	-	-	-	-	-	-	-	-	-	-	-	-	-	-	-	-	-	●	-	-	-	-	-	-	-	-	-

**TCGT-LF**

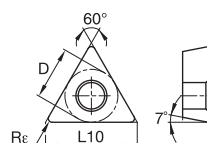
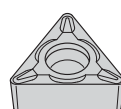
目录编号	D	L10	Re	KCP05	KCP10B	KCP10	KCP25B	KCP25	KCP30	KCP40	KCK05B	KCK05	KCK15B	KCK15	KCK20B	KCK20	KCM15B	KCM15	KCM25B	KCM25	KCM35	KU10	K313	K68	KCS10	KCU10	KCU25	KC5010	KC5025	KC5410	KT315	KTP10
TCGT110201LF	6,35	11,00	0,1	-	-	-	-	-	-	-	-	-	-	-	-	-	-	-	-	-	-	-	-	-	-	-	-	-	-	-	-	-
TCGT110204LF	6,35	11,00	0,4	-	-	-	-	-	-	-	-	-	-	-	-	-	-	-	-	-	-	-	-	-	-	-	-	-	-	-	-	-
TCGT16T301LF	9,53	16,50	0,1	-	-	-	-	-	-	-	-	-	-	-	-	-	-	-	-	-	-	-	-	-	-	-	-	-	-	-	-	-
TCGT16T302LF	9,53	16,50	0,2	-	-	-	-	-	-	-	-	-	-	-	-	-	-	-	-	-	-	-	-	-	-	-	-	-	-	-	-	-
TCGT16T304LF	9,53	16,50	0,4	-	-	-	-	-	-	-	-	-	-	-	-	-	-	-	-	-	-	-	-	-	-	●	●	●	●	●	●	●
TCGT16T308LF	9,53	16,50	0,8	-	-	-	-	-	-	-	-	-	-	-	-	-	-	-	-	-	-	-	-	-	-	●	●	●	●	●	●	●

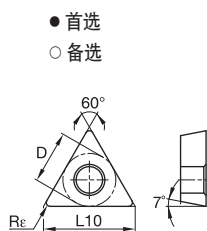
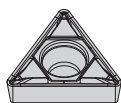

**TCMT-11**

目录编号	D	L10	Re	KCP05	KCP10B	KCP10	KCP25B	KCP25	KCP30	KCP40	KCK05B	KCK05	KCK15B	KCK15	KCK20B	KCK20	KCM15B	KCM15	KCM25B	KCM25	KCM35	KU10	K313	K68	KCS10	KCU10	KCU25	KC5010	KC5025	KC5410	KT315	KTP10
TCMT11020411	6,35	11,00	0,4	-	-	-	-	-	-	-	-	-	-	-	-	-	-	-	-	-	-	-	-	-	-	-	-	-	-	-	-	-
TCMT16T30411	9,53	16,50	0,4	-	-	-	-	-	-	-	-	-	-	-	-	-	-	-	-	-	-	-	-	-	-	-	-	-	-	-	-	-
TCMT16T30811	9,53	16,50	0,8	-	-	-	-	-	-	-	-	-	-	-	-	-	-	-	-	-	-	-	-	-	-	-	-	-	-	-	-	-

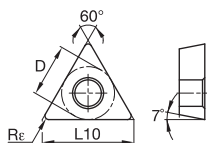
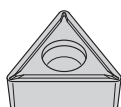

TCMT-FP

目录编号	D	L10	Rε
TCMT090204FP	5,56	9,63	0,4
TCMT090208FP	5,56	9,63	0,8
TCMT110202FP	6,35	11,00	0,2
TCMT110204FP	6,35	11,00	0,4
TCMT110304FP	6,35	11,00	0,4
TCMT110208FP	6,35	11,00	0,8
TCMT110308FP	6,35	11,00	0,8
TCMT110312FP	6,35	11,00	1,2
TCMT16T304FP	9,53	16,50	0,4
TCMT16T308FP	9,53	16,50	0,8
TCMT16T312FP	9,53	16,50	1,2
TCMT220408FP	12,70	22,00	0,8



TCMT-LF

目录编号	D	L10	Rε
TCMT110202LF	6,35	11,00	0,2
TCMT110204LF	6,35	11,00	0,4
TCMT110208LF	6,35	11,00	0,8
TCMT16T302LF	9,53	16,50	0,2
TCMT16T304LF	9,53	16,50	0,4
TCMT16T308LF	9,53	16,50	0,8
TCMT16T312LF	9,53	16,50	1,2
TCMT220408LF	12,70	22,00	0,8

	P	M	K	N	S	H	KCP05	KCP10B	KCP10	KCP25B	KCP25	KCP30	KCP40	KCK05B	KCK05	KCK15B	KCK15	KCK20B	KCK20	KCM15B	KCM15	KCM25B	KCM25	KCM35	KU10	K313	K68	KCS10	KCU10	KCU25	KC5010	KC5025	KC5410	KT315	KTP10	
TCMT090204FP	●	●	●	●	●	○	-	-	-	●	-	-	-	-	-	-	-	-	-	-	-	-	-	-	-	-	-	-	-	-	-	-	-	-	-	-
TCMT090208FP	●	●	●	●	●	○	-	-	-	-	-	-	-	-	-	-	-	-	-	-	-	-	-	-	-	-	-	-	-	-	-	-	-	-	-	-
TCMT110202FP	●	●	●	●	●	○	-	-	-	-	-	-	-	-	-	-	-	-	-	-	-	-	-	-	-	-	-	-	-	-	-	-	-	-	-	●
TCMT110204FP	●	●	●	●	●	○	-	-	●	-	●	-	-	-	-	-	-	●	-	-	-	-	-	-	-	-	-	-	-	-	-	-	-	-	-	●
TCMT110304FP	●	●	●	●	●	○	-	●	-	-	-	-	-	-	-	-	-	-	-	-	-	-	-	-	-	-	-	-	-	-	-	-	-	-	-	-
TCMT110208FP	●	●	●	●	●	○	-	-	-	●	-	-	-	-	-	-	-	-	-	-	-	-	●	-	-	-	-	-	-	-	-	-	-	-	-	-
TCMT110308FP	●	●	●	●	●	○	●	-	-	-	-	-	-	-	-	-	-	-	-	-	-	-	-	-	-	-	-	-	-	-	-	-	-	-	-	-
TCMT110312FP	●	●	●	●	●	○	●	-	-	-	-	-	-	-	-	-	-	-	-	-	-	-	-	-	-	-	-	-	-	-	-	-	-	-	-	-
TCMT16T304FP	●	●	●	●	●	○	-	-	●	-	●	-	-	-	-	-	-	-	-	-	-	-	-	-	-	-	-	-	-	-	-	-	-	-	-	-
TCMT16T308FP	●	●	●	●	●	○	-	-	●	-	●	-	-	-	-	-	-	-	-	-	-	-	●	-	-	-	-	-	-	-	-	-	-	-	-	●
TCMT16T312FP	●	●	●	●	●	○	-	-	●	-	-	-	-	-	-	-	-	-	-	-	-	-	-	-	-	-	-	-	-	-	-	-	-	-	-	-
TCMT220408FP	●	●	●	●	●	○	●	-	-	●	-	-	-	-	-	-	-	-	-	-	-	-	●	-	-	-	-	-	-	-	-	-	-	-	-	-





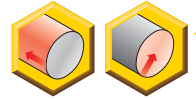
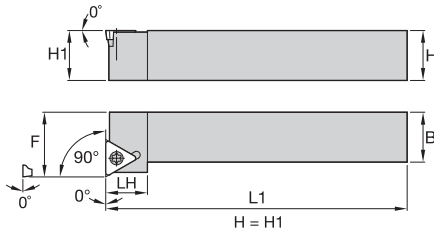
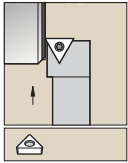

**STFC 90°**

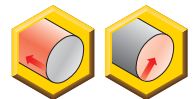
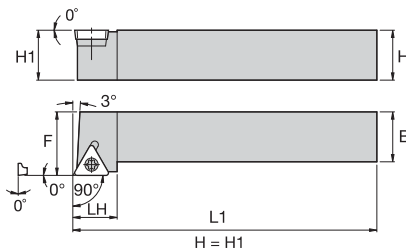
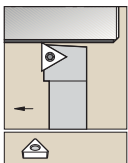
订货号	目录编号	H	B	F	L1	LH	刀片	垫片	垫片螺钉	六角	刀片螺钉	Torx
右手												
1244940	STFCR1616H11	16	16	20,0	100	16,0	TC..110204	—	—	—	MS1153	T7
1097880	STFCR1616H16	16	16	20,0	100	20,0	TC..16T308	SKTP343	SRS3	3.5 mm	MS1156	T15
1097877	STFCR2020K16	20	20	25,0	125	20,0	TC..16T308	SKTP343	SRS3	3.5 mm	MS1156	T15
1097878	STFCR2525M16	25	25	32,0	150	20,0	TC..16T308	SKTP343	SRS3	3.5 mm	MS1156	T15
左手												
1098022	STFCL2020K16	20	20	25,0	125	20,0	TC..16T308	SKTP343	SRS3	3.5 mm	MS1156	T15
1098023	STFCL2525M16	25	25	32,0	150	20,0	TC..16T308	SKTP343	SRS3	3.5 mm	MS1156	T15

**STGC 90°**

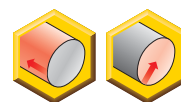
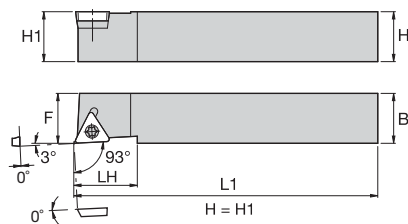
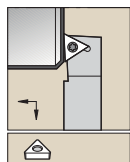

订货号	目录编号	H	B	F	L1	LH	刀片	垫片	垫片螺钉	六角	刀片螺钉	Torx
右手												
1097869	STGCR1212N11	12	12	16,0	160	16,0	TC..110204	—	—	—	MS1153	T7
1244944	STGCR1616H11	16	16	20,0	100	16,0	TC..110204	—	—	—	MS1153	T7
1097874	STGCR1616H16	16	16	20,0	100	20,0	TC..16T308	SKTP343	SRS3	3.5 mm	MS1156	T15
1097870	STGCR2020K16	20	20	25,0	125	20,0	TC..16T308	SKTP343	SRS3	3.5 mm	MS1156	T15
1097871	STGCR2525M16	25	25	32,0	150	20,0	TC..16T308	SKTP343	SRS3	3.5 mm	MS1156	T15
左手												
1098014	STGCL1212N11	12	12	16,0	160	16,0	TC..110204	—	—	—	MS1153	T7
1244943	STGCL1616H11	16	16	20,0	100	16,0	TC..110204	—	—	—	MS1153	T7
1098019	STGCL1616H16	16	16	20,0	100	20,0	TC..16T308	SKTP343	SRS3	3.5 mm	MS1156	T15
1098015	STGCL2020K16	20	20	25,0	125	20,0	TC..16T308	SKTP343	SRS3	3.5 mm	MS1156	T15
1098016	STGCL2525M16	25	25	32,0	150	20,0	TC..16T308	SKTP343	SRS3	3.5 mm	MS1156	T15



■ STJC-F 90°

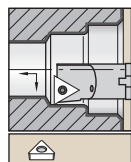

订货号	目录编号	H	B	F	L1	LH	刀片	刀片螺钉	Torx
右手									
1772197	STJCRF1212M11Q	12	12	12,0	150	16,0	TC..110204	MS1153	T7
左手									
1772198	STJCLF1212M11Q	12	12	12,0	150	16,0	TC..110204	MS1153	T7



带内冷功能的钢质刀柄。

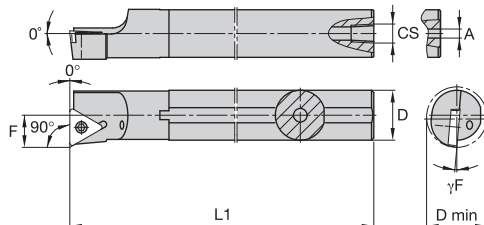

■ A-STFC 90°



订货号	目录编号	D	D min	F	L1	A	CS	γF°	刀片	垫片	垫片螺钉	六角	刀片螺钉	Torx
右手														
1098207	A10KSTFCR11	10	13,0	7,0	125	3,2	—	-7.0	TC..110204	—	—	—	MS1153	T7
1098211	A12MSTFCR11	12	16,0	9,0	150	—	1/16-27 NPT	-6.0	TC..110204	—	—	—	MS1153	T7
1098286	A32TSTFCR16	32	40,0	22,0	300	—	1/4-18 NPT	-2.0	TC..16T308	SKTP343	SRS3	3.5 mm	MS1156	T15
左手														
1098209	A10KSTFCL11	10	13,0	7,0	125	3,2	—	-7.0	TC..110204	—	—	—	MS1153	T7
1098213	A12MSTFCL11	12	16,0	9,0	150	—	1/16-27 NPT	-6.0	TC..110204	—	—	—	MS1153	T7





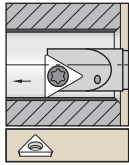

带内冷功能的钢质刀柄。

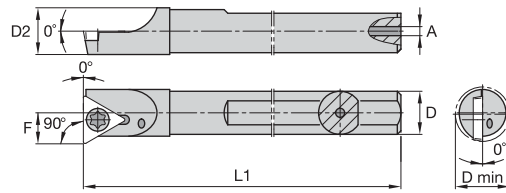

■ A-STFD 90°



订货号	目录编号	D	D min	D2	F	L1	A	刀片	刀片螺钉	Torx
右手										
1288884	A06HSTFDR07	6	7,1	6,2	3,7	100	1,0	TD..07S102	FC11	T7
1288898	A08HSTFDR07	8	9,1	8,2	4,8	102	1,5	TD..07S102	FC14	T7
左手										
1930573	A12MSTFDL11	12	13,2	12,2	6,8	152	3,0	TP..110202	QC26	T9

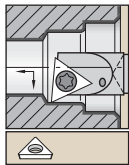

带内冷功能的钢质刀柄。

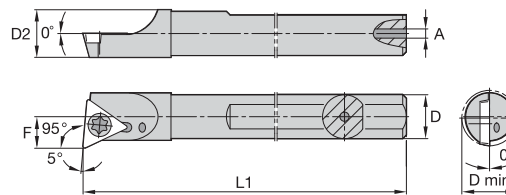

■ A-STLD 95°



订货号	目录编号	D	D min	D2	F	L1	A	刀片	刀片螺钉	Torx
右手										
1288886	A06HSTLDR07	6	7,1	6,2	3,7	100	1,0	TD..07S102	FC11	T7
1288900	A08HSTLDR07	8	9,1	8,2	4,8	102	1,5	TD..07S102	FC14	T7

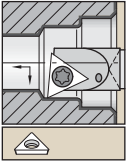

硬质合金刀柄（带内冷功能）。

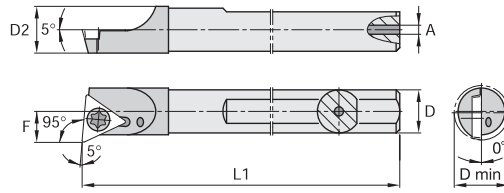
**E-STLD 95°**

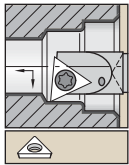

订货号	目录编号	D	D min	F	L1	A	刀片	刀片螺钉	Torx
右手									
1270982	E06MSTLDR07	6	7,1	3,7	152	1,2	TD..07S102	FC11	T7
1270992	E08MSTLDR07	8	9,2	4,8	152	2,4	TD..07S102	FC11	T7
左手									
1270981	E06MSTLDL07	6	7,1	3,7	152	1,2	TD..130805	FC11	T7
1270991	E08MSTLDL07	8	9,1	4,8	152	2,4	TD..07S102	FC14	T7

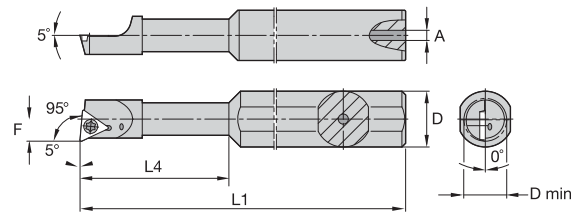

缩颈钢柄，带内冷功能。

**A-STLD 95° • 阶梯**

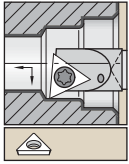
订货号	目录编号	D	D min	F	L1	L4	A	刀片	刀片螺钉	Torx
右手										
1289155	A0612XSTLDR0731	12	7,5	4,0	76	31,75	1,0	TD..07T1202	FC11	T7
左手										
1930492	A0616HSTLDR0731	16	7,5	4,0	102	31,75	1,0	TD..07S102	FC14	T7



缩颈硬质合金柄，  
带内冷功能。

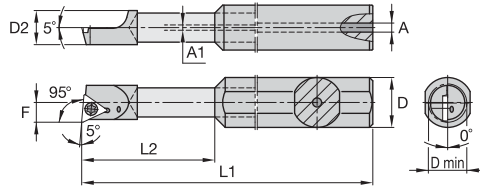

■ E-STLD 95° • 阶梯



订货号	目录编号	D	D min	D2	F	L1	L2	A	A1	刀片	刀片螺钉	Torx
右手												
1930512	E0812XSTLDR0738	12	9,1	7,9	4,8	76	38,1	3,2	2,0	TD..07S102	FC14	T7







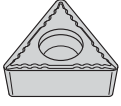

- 首选
- 备选

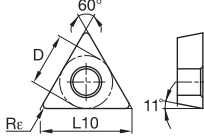

■ TPMT-UF

目录编号	D	L10	Re
TPMT110202UF	6,35	11,00	0,2
TPMT110204UF	6,35	11,00	0,4
TPMT16T308UF	9,53	16,50	0,8

	P	M	K	N	S	H	KCP05	KCP10B	KCP10	KCP25B	KCP25	KCP30	KCP40	KCK05B	KCK05	KCK15B	KCK15	KCK20B	KCK20	KCM15B	KCM15	KCM25B	KCM25	KCM35	KU10	K313	K68	KCS10	KCU10	KCU25	KC5010	KC5025	KC5410	KT315	KTP10	
P	●	●	●	●	●	●	●	●	●	●	●	●	●	●	●	●	●	●	●	●	●	●	●	●	●	●	●	●	●	●	●	●	●	●	●	●
M	●	●	●	●	●	●	●	●	●	●	●	●	●	●	●	●	●	●	●	●	●	●	●	●	●	●	●	●	●	●	●	●	●	●	●	●
K	○	○	○	○	○	○	○	○	○	○	○	○	○	○	○	○	○	○	○	○	○	○	○	○	○	○	○	○	○	○	○	○	○	○	○	○
N	○	○	○	○	○	○	○	○	○	○	○	○	○	○	○	○	○	○	○	○	○	○	○	○	○	○	○	○	○	○	○	○	○	○	○	○
S	○	○	○	○	○	○	○	○	○	○	○	○	○	○	○	○	○	○	○	○	○	○	○	○	○	○	○	○	○	○	○	○	○	○	○	○
H	○	○	○	○	○	○	○	○	○	○	○	○	○	○	○	○	○	○	○	○	○	○	○	○	○	○	○	○	○	○	○	○	○	○	○	○



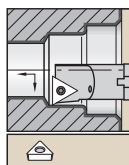

带内冷功能的钢质刀柄。

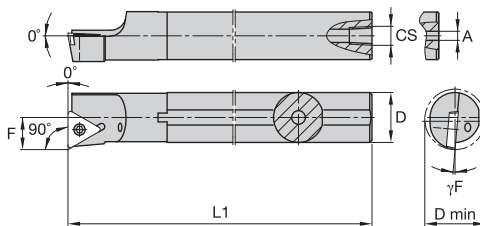

## ■ A-STFP 90°



订货号	目录编号	D	D min	F	L1	A	CS	γF°	刀片	垫片	垫片 螺钉	六角	刀片螺钉	Torx
右手														
1098154	A08JSTFPR09	8	11,0	6,0	110	2,4	—	-8.0	TP..090204	—	—	—	MS1933	T7
1098204	A10KSTFPR11	10	13,0	7,0	125	3,2	—	-4.0	TP..110204	—	—	—	MS1153	T7
1098210	A12MSTFPR11	12	16,0	9,0	150	4,0	1/16-27 NPT	-2.0	TP..110204	—	—	—	MS1153	T7
1098214	A16RSTFPR11	16	20,0	11,0	200	4,0	1/8-27 NPT	0.0	TP..110204	—	—	—	MS1153	T7
1098255	A20SSTFPR16	20	25,0	13,0	250	4,0	1/8-27 NPT	-2.0	TP..16T308	—	—	—	MS1155	T15
1098273	A25TSTFPR16	25	32,0	17,0	300	6,4	1/4-18 NPT	0.0	TP..16T308	—	—	—	MS1155	T15
1098285	A32TSTFPR16	32	40,0	22,0	300	—	1/4-18 NPT	-2.0	TP..16T308	SKTP343	SRS3	3.5 mm	MS1156	T15
左手														
1098155	A08JSTFPL09	8	11,0	6,0	110	2,4	—	-8.0	TP..090204	—	—	—	MS1933	T7
1098208	A10KSTFPL11	10	13,0	7,0	125	3,2	—	-4.0	TP..110204	—	—	—	MS1153	T7
1098212	A12MSTFPL11	12	16,0	9,0	150	4,0	1/16-27 NPT	-2.0	TP..110204	—	—	—	MS1153	T7
1098215	A16RSTFPL11	16	20,0	11,0	200	4,0	1/8-27 NPT	0.0	TP..110204	—	—	—	MS1153	T7
1098256	A20SSTFPL16	20	25,0	13,0	250	4,0	1/8-27 NPT	-2.0	TP..16T308	—	—	—	MS1155	T15
1098276	A25TSTFPL16	25	32,0	17,0	300	6,4	1/4-18 NPT	0.0	TP..16T308	—	—	—	MS1155	T15



ISO 车削刀具

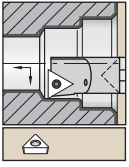

硬质合金刀柄（带内冷功能）。

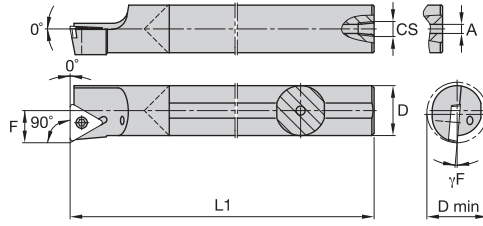

■ E-STFP 90°



订货号	目录编号	D	D min	F	L1	A	γF°	刀片	刀片螺钉	Torx
右手										
1152860	E08KSTFPR09A	8	11,0	6,0	125	2,4	-6.0	TP..090204	MS1933	T7
1152862	E10MSTFPR11A	10	13,0	7,0	150	3,2	-4.0	TP..110204	MS1153	T7
1104311	E12QSTFPR11	12	16,0	9,0	180	4,8	-2.0	TP..110204	MS1153	T7
1152874	E16RSTFPR11	16	20,0	11,0	200	5,5	0.0	TP..110204	MS1153	T7
1152908	E20SSTFPR16	20	25,0	13,0	250	7,1	-2.0	TP..16T308	MS1155	T15
左手										
1152863	E10MSTFPL11A	10	13,0	7,0	150	3,2	-4.0	TP..110204	MS1153	T7
1152873	E12QSTFPL11	12	16,0	9,0	180	4,8	-2.0	TP..110204	MS1153	T7
1152875	E16RSTFPL11	16	20,0	11,0	200	5,5	0.0	TP..110204	MS1153	T7
1152909	E20SSTFPL16	20	25,0	13,0	250	7,1	-2.0	TP..16T308	MS1155	T15

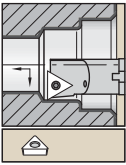

重金属镗杆，带内冷功能。

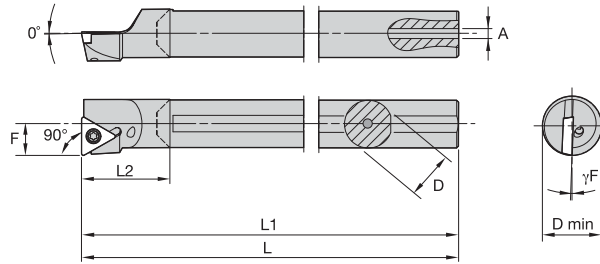
**■ L-STFP 90°**

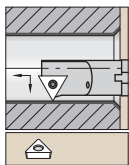

订货号	目录编号	D	D min	F	L1	L2	A	γF°	刀片	刀片螺钉	Torx
右手											
3331128	L08KSTFPR09	8	11,0	6,0	125	19,1	2,4	-6,0	TP..090204..	MS1933	T7
3331123	L12QSTFPR11	12	16,0	9,0	183	24,4	4,0	-2,0	TP..110204..	MS1153	T7
左手											
3331131	L08KSTFPL09	8	11,0	6,0	125	19,1	2,4	-6,0	TP..090204..	MS1933	T7

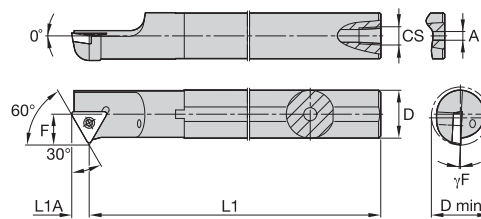

带内冷功能的钢质刀柄。

**■ A-STWP 60°**

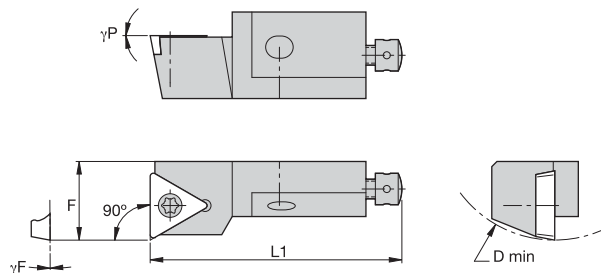
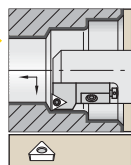
订货号	目录编号	D	D min	F	L1	L1A	A	CS	γF°	刀片	刀片螺钉	Torx
右手												
1098205	A10KSTWPR11	10	13,0	7,0	125	5,0	3,2	—	-4,0	TP..110204	MS1153	T7
1098216	A12MSTWPR11	12	16,0	9,0	150	—	4,0	1/16-27 NPT	-2,0	TP..110204	MS1153	T7
1098218	A16RSTWPR11	16	20,0	11,0	200	—	4,0	1/8-27 NPT	-2,0	TP..110204	MS1153	T7
左手												
1098206	A10KSTWPL11	10	13,0	7,0	125	—	3,2	—	-4,0	TP..110204	MS1153	T7



■ STFP 90°

订货号	目录编号	D min	F	L1	γF°	γP°	刀片
<b>右手</b>							
1098565	STFPR08CA09	25	10,0	32	0.0	0.0	TP..090204/TP..18151
1098563	STFPR10CA11	40	14,0	50	0.0	0.0	TP..110204/TP..2151
1098562	STFPR12CA16	50	20,0	55	0.0	0.0	TP..16T308/TP..3252
<b>左手</b>							
1098561	STFPL08CA09	25	10,0	32	0.0	0.0	TP..090204/TP..18151
1098559	STFPL10CA11	40	14,0	50	0.0	0.0	TP..110204/TP..2151
1098558	STFPL12CA16	50	20,0	55	0.0	0.0	TP..16T308/TP..3252

注: ANSI/ISO 兼容 60° 埋头孔加工刀片。  
 这款刀具还可应用 TPGM/TPGT/TPGW-21.5 刀片。  
 ANSI/ISO 兼容 60° 埋头孔加工刀片 (i.e., TPMT/TPGT/TPGW-32.5)。  
 90° 埋头孔加工刀片 (i.e., TPGM/TPGB-32.5) 不适合这款刀具。

■ 配件

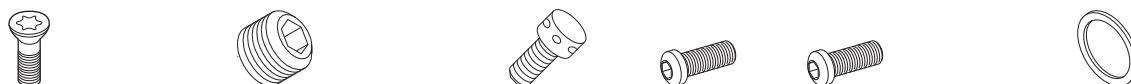

D min	刀片螺钉	Torx	径向调节螺钉	六角	轴向调整螺钉	安装螺钉	安装螺钉	六角	垫片
25	MS1152	T7	KUAM34	1.5 mm	KUAM20	MS2175	—	2.5 mm	CSWM 040 050
40	MS1153	T7	KUAM28	2 mm	KUAM30	191.405	—	4 mm	CSWM 060 050
50	MS1155	T15	KUAM23	2.5 mm	KUAM31	—	191.406	4 mm	CSWM 060 050

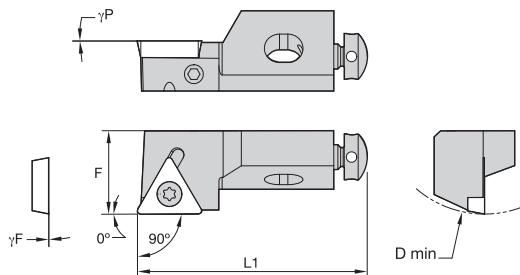
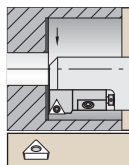

### ■ STGP 90°

订货号	目录编号	D min	F	L1	$\gamma_F^\circ$	$\gamma_P^\circ$	刀片
右手							
1098567	STGPR10CA11	40	14,0	50	0.0	0.0	TP..110204/TP..2151
1098566	STGPR12CA16	50	20,0	55	0.0	0.0	TP..16T308/TP..3252
左手							
1098762	STGPL08CA09	25	10,0	32	0.0	0.0	TP..090204/TP..18151
1098760	STGPL10CA11	40	14,0	50	0.0	0.0	TP..110204/TP..2151

注: ANSI/ISO 兼容 60° 埋头孔加工刀片。  
 这款刀具还可应用 TPGM/TPGT/TPGW-21.5\_ 刀片。  
 ANSI/ISO 兼容 60° 埋头孔加工刀片 (i.e., TPMT/TPGT/TPGW-32.5\_)。  
 90° 埋头孔加工刀片 (i.e., TPGM/TPGB-32.5\_) 不适合这款刀具。

### ■ 配件



D min	刀片螺钉	Torx	径向调节螺钉	六角	轴向调节螺钉	安装螺钉	安装螺钉	六角	垫片
25	MS1152	T7	KUAM34	1.5 mm	KUAM20	MS2175	—	2.5 mm	CSWM 040 050
40	MS1153	T7	KUAM28	2 mm	KUAM30	191.405	—	4 mm	CSWM 060 050
50	MS1155	T15	KUAM23	2.5 mm	KUAM31	—	191.406	4 mm	CSWM 060 050

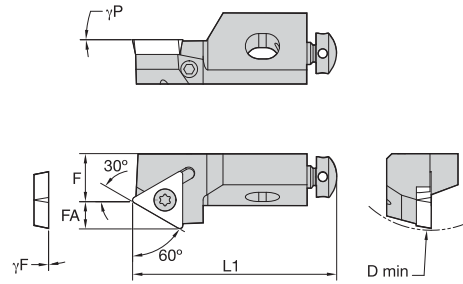
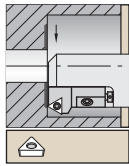

■ STTP 60°

订货号	目录编号	D min	F	L1	$\gamma_F^\circ$	$\gamma_P^\circ$	刀片
右手							
1098744	STTPR08CA09	25	6,0	32	0.0	0.0	TP..090204/TP..18151
1098742	STTPR10CA11	40	9,0	50	0.0	0.0	TP..110204/TP..2151
1098741	STTPR12CA16	50	13,0	55	0.0	0.0	TP..16T308/TP..3252

注: ANSI/ISO 兼容 60° 埋头孔加工刀片。  
这款刀具还可应用 TPGM/TPGT/TPGW-21.5\_ 刀片。

■ 配件



D min	刀片螺钉	Torx	径向调节螺钉	六角	轴向调整螺钉	安装螺钉	安装螺钉	六角	垫片
25	MS1152	T7	KUAM34	1.5 mm	KUAM20	MS2175	—	2.5 mm	CSWM 040 050
40	MS1153	T7	KUAM28	2 mm	KUAM30	191.405	—	4 mm	CSWM 060 050
50	MS1155	T15	KUAM23	2.5 mm	KUAM31	—	191.406	4 mm	CSWM 060 050

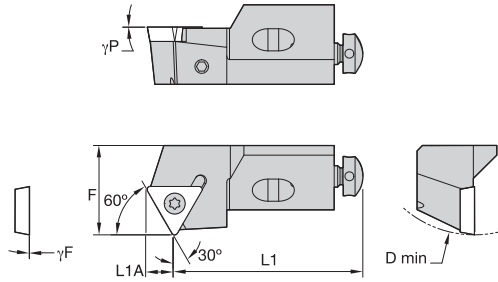
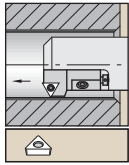

### ■ STWP 60°

订货号	目录编号	D min	F	L1	γF°	γP°	刀片
右手							
1098750	STWPR10CA11	40	14,0	44	0.0	0.0	TP..110204/TP..2151
1098749	STWPR12CA16	50	20,0	47	0.0	0.0	TP..16T308/TP..3252

注: ANSI/ISO 兼容 60° 埋头孔加工刀片。  
 这款刀具还可应用 TPGM/TPGT/TPGW-21.5\_ 刀片。

### ■ 配件



D min	刀片螺钉	Torx	径向调节螺钉	六角	轴向调整螺钉	安装螺钉	安装螺钉	六角	垫片
40	MS1153	T7	KUAM28	2 mm	KUAM30	191.405	—	4 mm	CSWM 060 050
50	MS1155	T15	KUAM23	2.5 mm	KUAM31	—	191.406	4 mm	CSWM 060 050





● 首选  
○ 备选

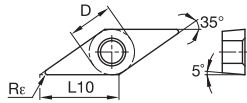
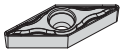

■ VBMT-FP

目录编号	D	L10	Re	KCP05	KCP10B	KCP10	KCP25B	KCP25	KCP30	KCP40	KCK05B	KCK05	KCK15B	KCK15	KCK20B	KCK20	KCM15B	KCM15	KCM25B	KCM25	KCM35	KU10	K313	K68	KCS10	KCU10	KCU25	KC5010	KC5025	KC5410	KT315	KTP10
VBMT110302FP	6,35	11,07	0,2	-	-	-	-	-	-	-	-	-	-	-	-	-	-	-	-	-	-	-	-	-	-	-	-	-	-	-	-	-
VBMT110304FP	6,35	11,07	0,4	-	-	●	-	●	-	-	-	-	-	-	-	-	-	-	-	-	-	-	-	-	-	●	-	-	-	-	-	-
VBMT110308FP	6,35	11,07	0,8	-	-	-	-	●	-	-	-	-	-	-	-	-	-	-	-	-	-	-	-	-	-	●	-	-	-	-	-	-
VBMT160402FP	9,53	16,61	0,2	-	-	-	-	●	-	-	-	-	-	-	-	-	-	-	-	-	-	-	-	-	-	-	-	-	-	-	-	-
VBMT160404FP	9,53	16,61	0,4	●	●	●	●	●	-	-	-	-	-	-	-	-	-	-	-	-	-	-	-	-	-	●	-	-	-	-	-	-
VBMT160408FP	9,53	16,61	0,8	●	●	●	●	●	-	-	-	-	-	-	-	-	-	-	-	-	-	-	-	-	-	●	-	-	-	-	-	-
VBMT160412FP	9,53	16,61	1,2	-	●	-	●	●	-	-	-	-	-	-	-	-	-	-	-	-	-	-	-	-	-	-	-	-	-	-	-	-

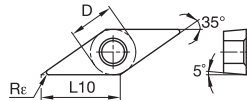
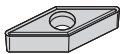

■ VBMT-LF

目录编号	D	L10	Re	KCP05	KCP10B	KCP10	KCP25B	KCP25	KCP30	KCP40	KCK05B	KCK05	KCK15B	KCK15	KCK20B	KCK20	KCM15B	KCM15	KCM25B	KCM25	KCM35	KU10	K313	K68	KCS10	KCU10	KCU25	KC5010	KC5025	KC5410	KT315	KTP10
VBMT110302LF	6,35	11,07	0,2	-	-	-	-	-	-	-	-	-	-	-	-	-	-	-	-	-	-	-	-	-	-	-	-	-	-	-	-	-
VBMT110304LF	6,35	11,07	0,4	-	●	●	-	●	-	-	-	-	-	-	-	-	-	-	-	-	-	-	-	-	-	-	-	-	-	-	-	-
VBMT110308LF	6,35	11,07	0,8	●	-	●	●	●	-	-	-	-	-	-	-	-	-	-	-	-	-	-	-	-	-	-	-	-	-	-	-	-
VBMT160402LF	9,53	16,61	0,2	-	-	-	-	-	-	-	-	-	-	-	-	-	-	-	-	-	-	-	-	-	-	-	-	-	-	-	-	-
VBMT160404LF	9,53	16,61	0,4	-	●	●	●	●	●	-	-	-	-	-	-	-	-	-	-	-	-	-	-	-	-	-	-	-	-	-	-	-
VBMT160408LF	9,53	16,61	0,8	●	●	●	●	●	●	-	-	-	-	-	-	-	-	-	-	-	-	-	-	-	-	-	-	-	-	-	-	-
VBMT160412LF	9,53	16,61	1,2	-	-	-	-	-	-	-	-	●	-	-	-	-	-	-	-	-	-	-	-	-	-	-	-	-	-	-	-	-

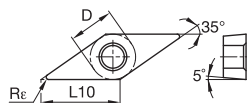

■ VBMT-MP

目录编号	D	L10	Re	KCP05	KCP10B	KCP10	KCP25B	KCP25	KCP30	KCP40	KCK05B	KCK05	KCK15B	KCK15	KCK20B	KCK20	KCM15B	KCM15	KCM25B	KCM25	KCM35	KU10	K313	K68	KCS10	KCU10	KCU25	KC5010	KC5025	KC5410	KT315	KTP10
VBMT160404MP	9,53	16,61	0,4	-	-	-	●	●	-	-	-	-	-	-	-	-	-	-	-	-	-	-	-	-	-	-	-	-	-	-	-	-
VBMT160408MP	9,53	16,61	0,8	-	-	-	●	●	-	-	-	-	-	-	-	-	-	-	-	-	-	-	-	-	-	-	-	-	-	-	-	-

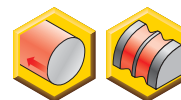
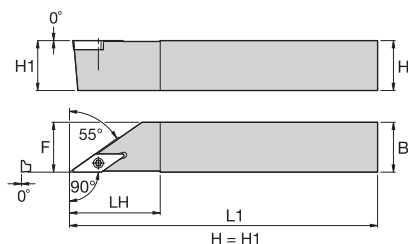
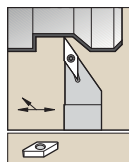

■ SVAB 90°



订货号	目录编号	H	B	F	L1	LH	刀片	刀片螺钉	Torx
<b>右手</b>									
1097722	SVABR1010M11Q	10	10	10,0	150	22,0	VB..110304	MS1153	T7
1097724	SVABR1212M11Q	12	12	12,0	150	22,0	VB..110304	MS1153	T7
1097726	SVABR1616K16Q	16	16	16,0	125	30,0	VB..160408	MS1155	T15
<b>左手</b>									
1097725	SVABL1212M11Q	12	12	12,0	150	22,0	VB..110304	MS1153	T7
1097727	SVABL1616K16Q	16	16	16,0	125	30,0	VB..160408	MS1155	T15

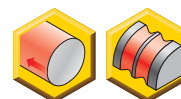
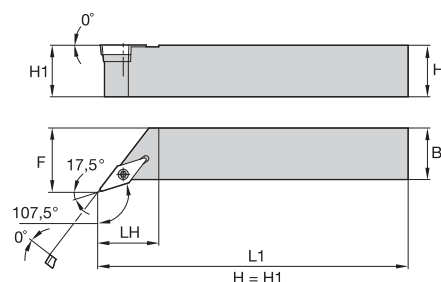
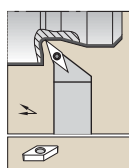

■ SVHB 107,5°

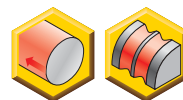
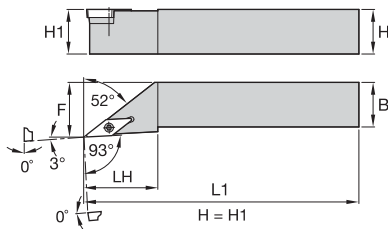
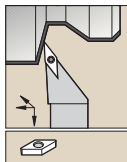

订货号	目录编号	H	B	F	L1	LH	刀片	垫片	垫片螺钉	六角	刀片螺钉	Torx
<b>右手</b>												
1097804	SVHBR1212N11	12	12	16,0	160	19,0	VB..110304	—	—	—	MS1153	T7
1097805	SVHBR1616H11	16	16	20,0	100	19,0	VB..110304	—	—	—	MS1153	T7
1244953	SVHBR2020K11	20	20	25,0	125	26,0	VB..110304	—	—	—	MS1153	T7
1097806	SVHBR2020K16	20	20	25,0	125	28,0	VB..160408	SKVN343	SRS3	3.5 mm	MS1156	T15
1097807	SVHBR2525M16	25	25	32,0	150	28,0	VB..160408	SKVN343	SRS3	3.5 mm	MS1156	T15
<b>左手</b>												
1097949	SVHBL1212N11	12	12	16,0	160	19,0	VB..110304	—	—	—	MS1153	T7
1097950	SVHBL1616H11	16	16	20,0	100	19,0	VB..110304	—	—	—	MS1153	T7
1244949	SVHBL2020K11	20	20	25,0	125	26,0	VB..110304	—	—	—	MS1153	T7
1097951	SVHBL2020K16	20	20	25,0	125	28,0	VB..160408	SKVN343	SRS3	3.5 mm	MS1156	T15
1097952	SVHBL2525M16	25	25	32,0	150	28,0	VB..160408	SKVN343	SRS3	3.5 mm	MS1156	T15

**SVJB 93°**

订货号	目录编号	H	B	F	L1	LH	刀片	垫片	垫片螺钉	六角	刀片螺钉	Torx
<b>右手</b>												
1097800	SVJBR1212N11	12	12	16,0	160	22,0	VB..110304	—	—	—	MS1153	T7
1097801	SVJBR1616H11	16	16	20,0	100	22,0	VB..110304	—	—	—	MS1153	T7
1244959	SVJBR1616H16	16	16	20,0	100	35,0	VB..160408	SKVN343	SRS3	3.5 mm	MS1156	T15
1252235	SVJBR2020K11	20	20	25,0	125	26,0	VB..110304	—	—	—	MS1153	T7
1097802	SVJBR2020K16	20	20	25,0	125	35,0	VB..160408	SKVN343	SRS3	3.5 mm	MS1156	T15
1097803	SVJBR2525M16	25	25	32,0	150	35,0	VB..160408	SKVN343	SRS3	3.5 mm	MS1156	T15
1244992	SVJBR3225P16	32	25	32,0	170	35,0	VB..160408	SKVN343	SRS3	3.5 mm	MS1156	T15
<b>左手</b>												
1097945	SVJBL1212N11	12	12	16,0	160	22,0	VB..110304	—	—	—	MS1153	T7
1097946	SVJBL1616H11	16	16	20,0	100	22,0	VB..110304	—	—	—	MS1153	T7
1244957	SVJBL1616H16	16	16	20,0	100	35,0	VB..160408	SKVN343	SRS3	3.5 mm	MS1156	T15
1252234	SVJBL2020K11	20	20	25,0	125	26,0	VB..110304	—	—	—	MS1153	T7
1097947	SVJBL2020K16	20	20	25,0	125	35,0	VB..160408	SKVN343	SRS3	3.5 mm	MS1156	T15
1097948	SVJBL2525M16	25	25	32,0	150	35,0	VB..160408	SKVN343	SRS3	3.5 mm	MS1156	T15
1192560	SVJBL3225P16	32	25	32,0	170	35,0	VB..160408	SKVN343	SRS3	3.5 mm	MS1156	T15

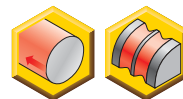
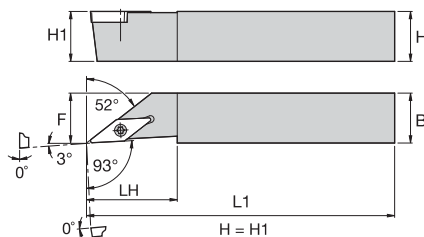
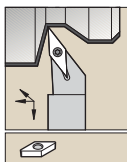
**SVJB-F 93°**

订货号	目录编号	H	B	F	L1	LH	刀片	刀片螺钉	Torx
<b>右手</b>									
1097797	SVJBRF1010M11Q	10	10	10,0	150	23,0	VB..110304	MS1153	T7
1097798	SVJBRF1212M11Q	12	12	12,0	150	23,0	VB..110304	MS1153	T7
1097799	SVJBRF1616K16Q	16	16	16,0	125	31,0	VB..160408	MS1155	T15
<b>左手</b>									
1097942	SVJBLF1010M11Q	10	10	10,0	150	23,0	VB..110304	MS1153	T7
1097943	SVJBLF1212M11Q	12	12	12,0	150	23,0	VB..110304	MS1153	T7
1097944	SVJBLF1616K16Q	16	16	16,0	125	31,0	VB..160408	MS1155	T15

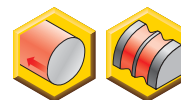
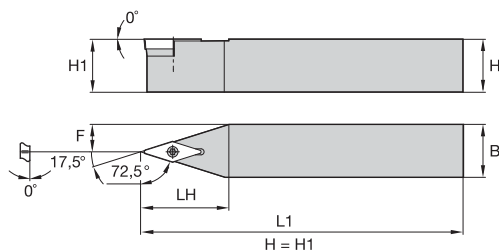
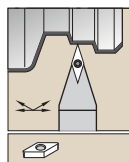

■ SVWB 72,5°



订货号	目录编号	H	B	F	L1	LH	刀片	垫片	垫片螺钉	六角	刀片螺钉	Torx
1097990	SVBN1212N11	12	12	6,0	160	26,0	VB..110304	—	—	—	MS1153	T7
1097991	SVBN1616H11	16	16	8,0	100	26,0	VB..110304	—	—	—	MS1153	T7
1244961	SVBN1616H16	16	16	8,0	100	33,0	VB..160408	SKVN343	SRS3	3.5 mm	MS1156	T15
1244962	SVBN2020K11	20	20	10,0	125	26,0	VB..110304	—	—	—	MS1153	T7
1097992	SVBN2020K16	20	20	10,0	125	33,0	VB..160408	SKVN343	SRS3	3.5 mm	MS1156	T15
1097993	SVBN2525M16	25	25	12,5	150	33,0	VB..160408	SKVN343	SRS3	3.5 mm	MS1156	T15
1192561	SVBN3225P16	32	25	12,5	170	33,0	VB..160408	SKVN343	SRS3	3.5 mm	MS1156	T15

螺纹接口镗杆

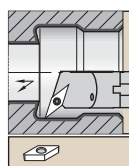

带内冷功能的钢质刀柄。

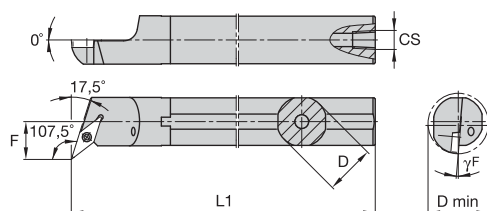

■ A-SVQB 107,5°



订货号	目录编号	D	D min	F	L1	CS	γF°	刀片	刀片螺钉	Torx
右手										
1098232	A16RSVQBR11	16	20,0	11,0	200	1/8-27 NPT	-7.0	VB..110304	MS1153	T7
1098248	A20SSVQBR11	20	25,0	13,0	250	1/8-27 NPT	-6.0	VB..110304	MS1153	T7
1098274	A25TSVQBR16	25	32,0	17,0	300	1/4-18 NPT	-6.0	VB..160408	MS1155	T15
左手										
1098233	A16RSVQBL11	16	20,0	11,0	200	1/8-27 NPT	-7.0	VB..110304	MS1153	T7
1098253	A20SSVQBL11	20	25,0	13,0	250	1/8-27 NPT	-6.0	VB..110304	MS1153	T7
1098277	A25TSVQBL16	25	32,0	17,0	300	1/4-18 NPT	-6.0	VB..160408	MS1155	T15

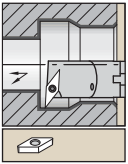

带内冷功能的钢质刀柄。

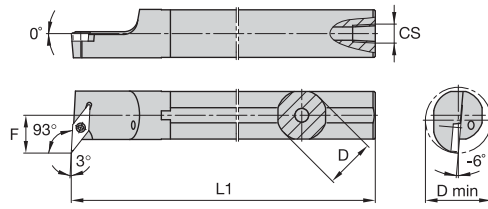

■ A-SVUB 93°



订货号	目录编号	D	D min	F	L1	CS	刀片	刀片螺钉	Torx
右手									
1098249	A20SSVUBR11	20	25,0	13,0	250	1/8-27 NPT	VB..110304	MS1153	T7
1098275	A25TSVUBR16	25	32,0	17,0	300	1/4-18 NPT	VB..160408	MS1155	T15
左手									
1098254	A20SSVUBL11	20	25,0	13,0	250	1/8-27 NPT	VB..110304	MS1153	T7
1098278	A25TSVUBL16	25	32,0	17,0	300	1/4-18 NPT	VB..160408	MS1155	T15

ISO 车削刀具



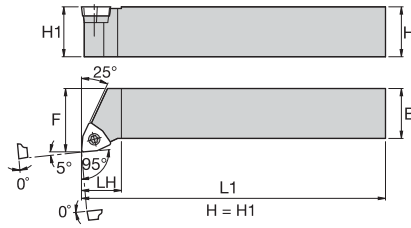
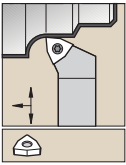

**■ SWLC 95°**

订货号	目录编号	H	B	F	L1	LH	刀片	垫片	垫片螺钉	六角	刀片螺钉	Torx
右手												
1097732	SWLCR2020K06	20	20	25,0	125	16,0	WC..06T308	SKWP343	SRS3	3.5 mm	MS1156	T15

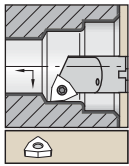
## 螺纹接口镗杆

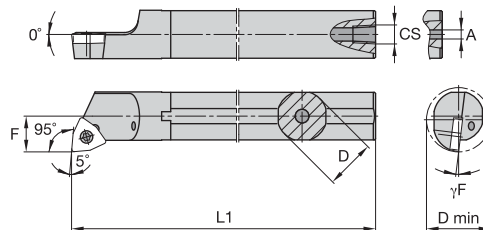

带内冷功能的钢质刀柄。

**■ A-SWLC 95°**

订货号	目录编号	D	D min	F	L1	A	CS	γF°	刀片	刀片螺钉	Torx
右手											
1328642	A06MSWLCR2	10	12,2	6,4	152	3,2	—	-8.0	WC..2151	MS1939	T7
1328644	A08RSWLCR2	13	15,2	7,9	203	4,0	1/16-27 NPT	-6.0	WC..2151	MS1153	T7
1098062	A10KSWLCR04	10	13,0	7,0	125	3,0	—	-7.0	WC..040204	MS1153	T7
1328646	A10SSWLCR3	16	19,6	10,3	254	4,0	1/8-27 NPT	-7.0	WC..3252	MS1155	T15
1098063	A12MSWLCR04	12	16,0	9,0	150	—	1/16-27 NPT	-6.0	WC..040204	MS1153	T7
1098064	A16RSWLCR06	16	20,0	11,0	200	4,0	1/8-27 NPT	-7.0	WC..06T308	MS1155	T15
1098065	A20SSWLCR06	20	25,0	13,0	250	4,0	1/8-27 NPT	-5.0	WC..06T308	MS1155	T15
左手											
1098069	A16RSWLCR06	16	20,0	11,0	200	4,0	1/8-27 NPT	-7.0	WC..06T308	MS1155	T15





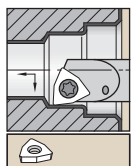

带内冷功能的钢质刀柄。

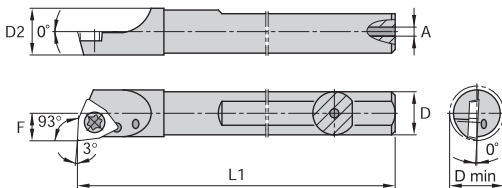

■ A-SWUP 93°



订货号	目录编号	D	D min	D2	F	L1	A	刀片	刀片螺钉	Torx
右手										
1930544	A06HSWUPRS3	6	6,8	6,2	3,4	102	1,0	WP..S30104	CT11	T6
1930546	A08HSWUPRS3	8	8,8	8,2	4,4	102	2,4	WP..S30104	CT11	T6
1930556	A12MSWUPR04	12	12,9	12,2	6,6	152	4,0	WP..040204	QTM20	T7

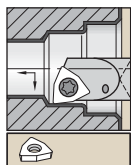

硬质合金刀柄（带内冷功能）。

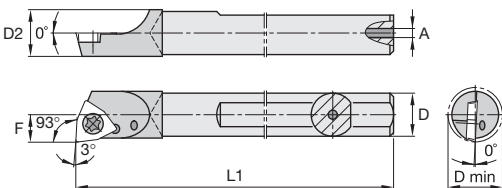

■ E-SWUP 93°



订货号	目录编号	D	D min	D2	F	L1	A	刀片	刀片螺钉	Torx
右手										
1930550	E06MSWUPRS3	6	6,8	6,2	3,4	152	1,2	WP..S30104	CT11	T6
1930552	E08MSWUPRS3	8	8,8	—	4,4	152	2,4	WP..S30104	CT11	T6
1930558	E10SSWUPR04	10	11,0	—	5,6	254	3,2	WP..040204	QTM20	T7
1930560	E12SSWUPR04	12	12,9	—	6,6	254	4,7	WP..040204	QTM20	T7
左手										
1930549	E06MSWUPLS3	6	6,8	6,2	3,4	152	1,2	WP..S30104	CT11	T6

# 应用超硬材料材质刀片进行车削加工

## 陶瓷、PcBN 和 PCD 刀片

这些先进材料制成的刀片，包括陶瓷、PcBN (多晶立方氮化硼)，以及 PCD (多晶金刚石)，可以用于硬材料车削，以及铸铁材料、硬化材料、高温合金和非铁材料的加工应用。

提供陶瓷、PcBN 和 PCD 刀片：

- 改善性能。
- 更出色的耐磨性。



### 陶瓷刀片

- 用于铸铁材料加工的氮化硅陶瓷材质。
- 用于硬切削和铸铁材料精加工的混合陶瓷材质。
- 用于高温合金材料加工和硬切削的晶须陶瓷材质。



## PcBN

### 整体刀片

- 刀片仅采用 PcBN 材料。
- 无材料接合点。
- 最佳的热吸收性能。
- 可在极高温环境中使用。

KBK45



### 焊刃刀片

- 需要载体和 PcBN 刀刃。
- 刀刃钎焊至载体上。
- 载体上应当具备刀槽，可以安装并夹持刀刃。

KBH20™

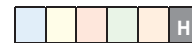

## PCD

- 专门用于非铁金属材料加工。
- 与硬质合金刀具相比具有明显的硬度优势。
- 更高的切削速度和更长的刀具寿命，因此可提高生产率。
- 在常规刀具无法加工的材料应用中具有最佳的性能。

KD1400

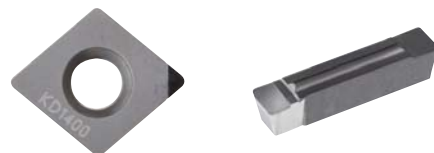



这份指南使用非常方便，可以快速找到客户需要查找的产品。

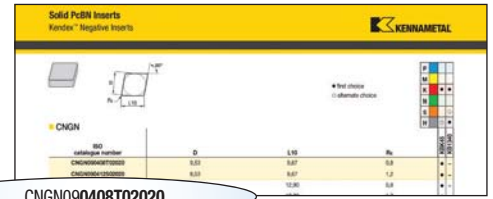

CNGN090408T020

04	08		T	020	20																																																																																														
厚度 “S”	刀尖 半径 “Re”	刀片方向 (可选)	切削刃 (可选)	T型倒棱宽度 (可选)	T型倒棱 角度 (可选)	刀尖 类型 (可选)	断屑器 (可选)																																																																																												
<table border="1"> <tr><th>图标</th><th>厚度</th></tr> <tr><th>mm</th><th>mm</th></tr> <tr><td>—</td><td>0,79</td></tr> <tr><td>T0</td><td>1,00</td></tr> <tr><td>01</td><td>11,59</td></tr> <tr><td>T1</td><td>1,98</td></tr> <tr><td>02</td><td>2,38</td></tr> <tr><td>03</td><td>3,18</td></tr> <tr><td>T3</td><td>3,97</td></tr> <tr><td>04</td><td>4,76</td></tr> <tr><td>05</td><td>5,56</td></tr> <tr><td>06</td><td>6,35</td></tr> <tr><td>07</td><td>7,94</td></tr> <tr><td>09</td><td>9,52</td></tr> <tr><td>11</td><td>11,11</td></tr> <tr><td>12</td><td>12,70</td></tr> </table>	图标	厚度	mm	mm	—	0,79	T0	1,00	01	11,59	T1	1,98	02	2,38	03	3,18	T3	3,97	04	4,76	05	5,56	06	6,35	07	7,94	09	9,52	11	11,11	12	12,70	<table border="1"> <tr><th>图标</th><th>圆角</th></tr> <tr><th>mm</th><th>mm</th></tr> <tr><td>X0</td><td>0,4</td></tr> <tr><td>01</td><td>0,1</td></tr> <tr><td>02</td><td>0,2</td></tr> <tr><td>04</td><td>0,4</td></tr> <tr><td>08</td><td>0,8</td></tr> <tr><td>12</td><td>1,2</td></tr> <tr><td>16</td><td>1,6</td></tr> <tr><td>20</td><td>2,0</td></tr> <tr><td>24</td><td>2,4</td></tr> <tr><td>28</td><td>2,8</td></tr> <tr><td>32</td><td>3,2</td></tr> <tr><td>00</td><td>圆形刀片</td></tr> <tr><td>M0</td><td></td></tr> </table>	图标	圆角	mm	mm	X0	0,4	01	0,1	02	0,2	04	0,4	08	0,8	12	1,2	16	1,6	20	2,0	24	2,4	28	2,8	32	3,2	00	圆形刀片	M0		<p>R = 右手</p> <p>L = 左手</p> <p>N = 中性</p>	<p>F* 尖角型</p> <p>E 圆角型</p> <p>T* 倒角型</p> <p>S* 倒角型和圆角型</p> <p>K 双倒角</p> <p>P 双倒角和圆角形</p> <p>* 同时提供修光刃类型产品。</p>	<table border="1"> <tr><th>图标</th><th>倒棱宽度</th></tr> <tr><th>ISO</th><th>mm</th></tr> <tr><td>010</td><td>0,01</td></tr> <tr><td>020</td><td>0,02</td></tr> </table>	图标	倒棱宽度	ISO	mm	010	0,01	020	0,02	<table border="1"> <tr><th>图标</th><th>倒棱角度</th></tr> <tr><td>10</td><td>10°</td></tr> <tr><td>15</td><td>15°</td></tr> <tr><td>20</td><td>20°</td></tr> <tr><td>25</td><td>25°</td></tr> <tr><td>30</td><td>30°</td></tr> </table>	图标	倒棱角度	10	10°	15	15°	20	20°	25	25°	30	30°	<p>FW = 精加工修光刃</p> <p>MW = 一般加工修光刃</p>	<table border="1"> <tr><th>图标</th><th>应用</th></tr> <tr><td>C</td><td>整面式</td></tr> <tr><td>M</td><td>微型刀尖</td></tr> <tr><td>MT</td><td>多刃</td></tr> <tr><td>ST</td><td>单刃</td></tr> </table>	图标	应用	C	整面式	M	微型刀尖	MT	多刃	ST	单刃
图标	厚度																																																																																																		
mm	mm																																																																																																		
—	0,79																																																																																																		
T0	1,00																																																																																																		
01	11,59																																																																																																		
T1	1,98																																																																																																		
02	2,38																																																																																																		
03	3,18																																																																																																		
T3	3,97																																																																																																		
04	4,76																																																																																																		
05	5,56																																																																																																		
06	6,35																																																																																																		
07	7,94																																																																																																		
09	9,52																																																																																																		
11	11,11																																																																																																		
12	12,70																																																																																																		
图标	圆角																																																																																																		
mm	mm																																																																																																		
X0	0,4																																																																																																		
01	0,1																																																																																																		
02	0,2																																																																																																		
04	0,4																																																																																																		
08	0,8																																																																																																		
12	1,2																																																																																																		
16	1,6																																																																																																		
20	2,0																																																																																																		
24	2,4																																																																																																		
28	2,8																																																																																																		
32	3,2																																																																																																		
00	圆形刀片																																																																																																		
M0																																																																																																			
图标	倒棱宽度																																																																																																		
ISO	mm																																																																																																		
010	0,01																																																																																																		
020	0,02																																																																																																		
图标	倒棱角度																																																																																																		
10	10°																																																																																																		
15	15°																																																																																																		
20	20°																																																																																																		
25	25°																																																																																																		
30	30°																																																																																																		
图标	应用																																																																																																		
C	整面式																																																																																																		
M	微型刀尖																																																																																																		
MT	多刃																																																																																																		
ST	单刃																																																																																																		

“D”	“D”公差±				“D”	“B”公差±			
	形状 S, T, C, R, & W	M级公差		U级公差		形状 S, T, C, R, & W	M级公差		U级公差
		形状 D	形状 V	形状 S, T, & C			形状 D	形状 V	形状 S, T, & C
mm	mm	mm	mm	mm	mm	mm	mm	mm	
3,97	0,05	—	—	—	3,97	0,08	—	—	—
4,76	0,05	—	—	0,08	4,76	0,08	—	—	0,13
5,56	0,05	0,05	0,05	0,08	5,56	0,08	0,11	—	0,13
6,35	0,05	0,05	0,05	0,08	6,35	0,08	0,11	—	0,13
7,94	0,05	0,05	0,05	0,08	7,94	0,08	0,11	—	0,13
9,52	0,05	0,05	0,05	0,08	9,52	0,08	0,11	0,18	0,13
11,11	0,08	0,08	0,08	0,13	11,11	0,13	0,15	—	—
12,70	0,08	0,08	0,08	0,13	12,70	0,13	0,15	0,25	0,20
14,29	0,08	0,08	0,08	0,13	14,29	0,13	0,15	—	—
15,88	0,10	0,10	0,10	0,18	15,88	0,15	0,18	—	0,27
17,46	0,10	0,10	0,10	0,18	17,46	0,15	0,18	—	0,27
19,05	0,10	0,10	0,10	0,18	19,05	0,15	0,18	—	0,27
22,22	0,13	—	—	0,25	22,22	0,15	—	—	0,38
25,40	0,13	—	—	0,25	25,40	0,18	—	—	0,38
31,75	0,15	—	—	0,25	31,75	0,20	—	—	0,38

# ➤ 用于铸铁材料加工的先进材质



## 主要应用

肯纳金属公司利用 Beyond™ 技术，并根据加工特点制成的先进材质具有更好的耐磨性和韧性。

KYK 刀片是对铸铁材料进行高速、连续车削以及轻微断续车削加工的首选。该产品的优势包括改善了刀片的抗断裂韧性和耐磨性，并拓宽了应用范围。在铸铁材料加工中，肯纳金属公司将 KYK10™、CVD 涂层 KYK25™、以及其它陶瓷材质结合在一起，为客户提供完整的高性能陶瓷系列刀片产品，可以缩短客户的加工周期，并降低加工成本。

肯纳金属 SiAlON 材质产品，例如 KYK10，可用于高速切削加工，切削速度可达到 PcBN 产品的速度范围，并可用于各种加工性能的铸铁材料加工。在铸铁材料加工中，肯纳金属公司将 SiAlON 材料技术、CVD 涂层技术，以及 PcBN 材质技术结合在一起，为客户提供完整的高性能刀具系列产品，可以帮助客户缩短加工周期，并降低加工成本。

## 特点及优势

### 整体 PcBN 刀片

#### KBK45™

- 产品设计具有更好的耐磨性。
- 是单位工件成本较低应用的首选。
- 可用于粗加工和精加工。
- 金色外观，改善使用状态监控性能。

#### KB1340™

- 产品设计具有更好的耐磨性。
- 耐高温。
- 可用于粗加工和精加工。

### PcBN 焊刃刀片

#### KB5630™

- 层迭材料超精加工。
- 极佳的刃口稳定性。
- PVD 涂层确保更稳定的刀具寿命，在多种加工性能材料应用中也是如此。

#### KB1345™

- 高 CBN 含量，耐磨型焊刃刀片材质。
- 超细晶粒 PcBN 结构，适合超精加工应用。

**KBK45™** 在铸铁材料加工中具有卓越的单位工件成本优势。

**KB5630™** 在冷硬铁材料加工中具有极佳的耐磨性能。



## 陶瓷刀片

### **KYK10™**

- 提高了材质的耐磨性及韧性，比现有的KY1310™提高了20%的寿命。
- 特别适合铸铁材料的连续车削和轻微断续车削加工。

### **KYK25™**

- 12微米厚度涂层具有极佳的耐磨性，预涂层处理使刀片在铸铁材料加工中具有更加稳定的性能，以及更长的使用寿命。
- 与竞争性CVD涂层陶瓷材质相比，这种材质可以延迟刀具寿命达30%。

### **KY3500™**

- 在切削速度高达1000米/分钟的湿式切削或干式切削加工中，具有卓越的粗加工和精加工性能。
- 在对球墨铸铁或可锻铸铁(<70 KSI 抗拉强度)进行苛刻断续加工，切削速度为250-450米/分钟时具有良好的加工性能。

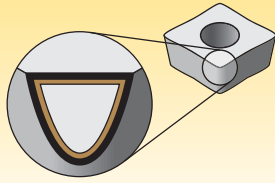

涂层更适合高速加工，并且可用于精加工至轻型粗加工的应用范围。

P	钢
M	不锈钢
K	铸铁
N	非铁金属
S	高温合金
H	硬材料

耐磨性 ←————→ 韧性

涂层		材质说明		05	10	15	20	25	30	35	40	45
整体 PcBN 材质	KBK45	成分：一种 PVD TiN 涂层，高 CBN 含量，有多个切削刃的整体 PcBN 刀片。 应用：用于灰铸铁和硬铸铁材料的粗加工应用。还可用于冷硬铸铁以及全珠光体铸铁材料的精加工应用。与 PcBN 焊刃刀片相比，整体 PcBN 刀片具有更好的加工安全性和抗冲击性，同时具有更好的切深性能。 	K									
	KB1340	成份：一种具有高 CBN 含量，有多个切削刃的整体 PcBN 刀片。 应用范围：可用于珠光体灰铸铁、冷淬铸铁、高铬合金钢材料的粗加工至精加工；还可用于硬化钢材料 (>45 HRC) 的重型切削加工。与 PcBN 焊刃刀片相比，整体 PcBN 刀片具有更好的加工安全性和抗冲击性，同时具有更好的切深性能。	K									
PcBN 焊刃刀片	KB1345	成分：一种具有高 CBN 含量的材质，PCBN 刀刃钎焊至硬质合金刀片上。 应用：可用于珠光体灰铸铁、冷淬铁、高铬合金钢、和烧结粉末金属材料的粗加工至精加工；还可用于硬化钢材料 (>45 HRC) 的重型切削加工。还可用于冷硬铸铁以及全珠光体铸铁材料的精加工应用。PcBN 焊刃刀片有多种刀片类型，包括特别适合镗削加工的正前角槽型刀片。	K									
	KB5630	成分：一种高 PcBN 含量的材质，PVD AlTiN 涂层具有更高的耐磨性。 应用：用于对硬化钢材料（硬度大于45 HRC），高磨损性的工件材料，如烧结阀座材料，粉末冶金钢，以及高硬度的高合金铸铁材料，进行粗加工至精加工。PVD 涂层可以避免月牙洼磨损，并提高抗崩刃性能。提供多种类型产品，包括特别适合镗削加工的螺纹接口槽型产品。	K									
陶瓷材质	KYK10	成分：一种最新型的 SiAlON 陶瓷材质。 应用：更出色的耐磨性。用于对灰铸铁材料，包括出现鳞刺的材料的高速连续车削加工。用于对各种加工性能的铸铁材料的加工。 	K									
	KYK25	成分：纯氮化硅陶瓷材质，涂层为氧化铝 TiCN CVD 材料。 应用：具有极高的韧性和卓越的抗刃口磨损性能。用于对灰铸铁、球墨铸铁及蠕墨铸铁材料的通用机械加工。用于对各种加工性能的铸铁材料的加工。 	K									
	KY3500	成分：纯氮化硅的材质。 应用：具有出色的韧性。用于对灰铸铁材料进行大进给的粗加工，包括断续切削加工。	K									



### ■ 铸铁材料的机加工性能

- 非时效铸铁难加工，会缩短刀具寿命。
- 含硫量低会缩短刀具寿命。
- 高钛含量会显著缩短刀具寿命。
- 增加铁素体含量会导致化学磨损增加，并显著缩短刀具寿命。
- 蠕墨铸铁材料的化学损性高。

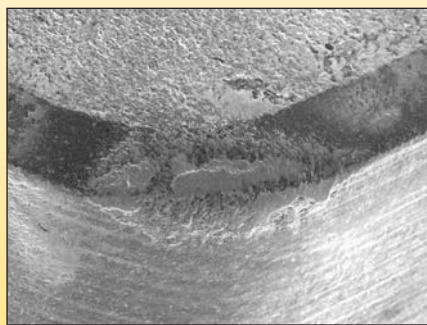

KB1340™ 的正确应用 — 保护层结构，  
刀具寿命应超过 70 公里的加工长度。

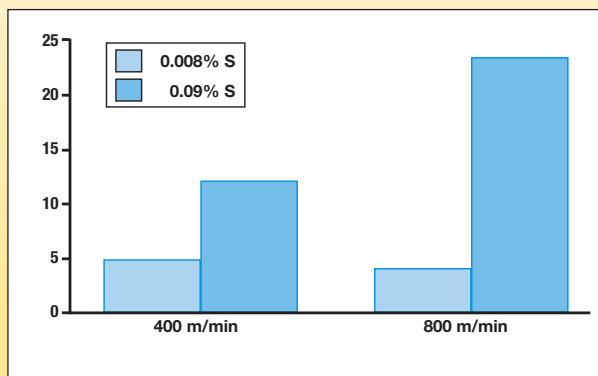

PcBN 刀具在对两种不同灰口铸铁材料  
(主要是硫含量不同) 进行加工时刀具寿命的对比。

### ■ 灰口铸铁制动盘加工 • 陶瓷刀片与 PcBN 刀片



(a)

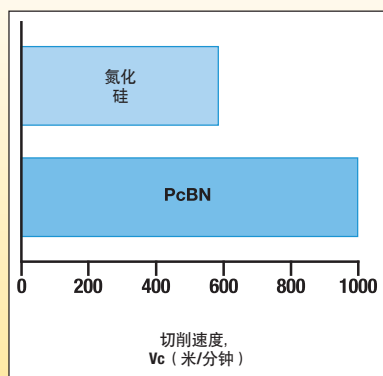

(b)

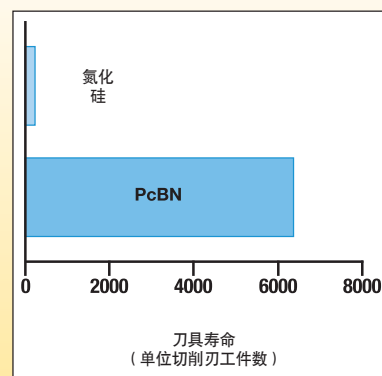

(c)

与氮化硅陶瓷刀片相比，PcBN 刀片在加工灰口铸铁制动盘零件 (a) 时，  
可以提高切削速度 (b)，延长刀具寿命 (c)，从而可以提高生产率。

■ 选择切削材料

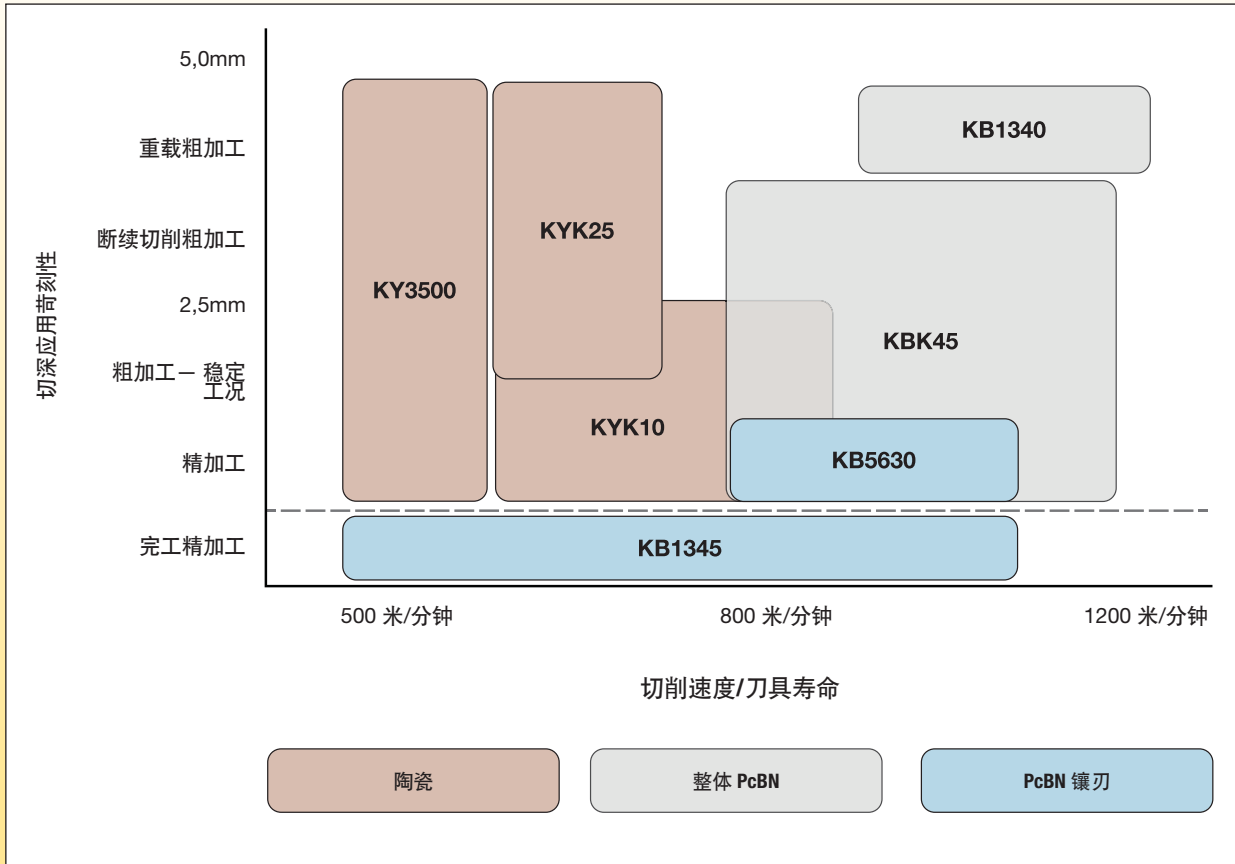

■ 切削深度

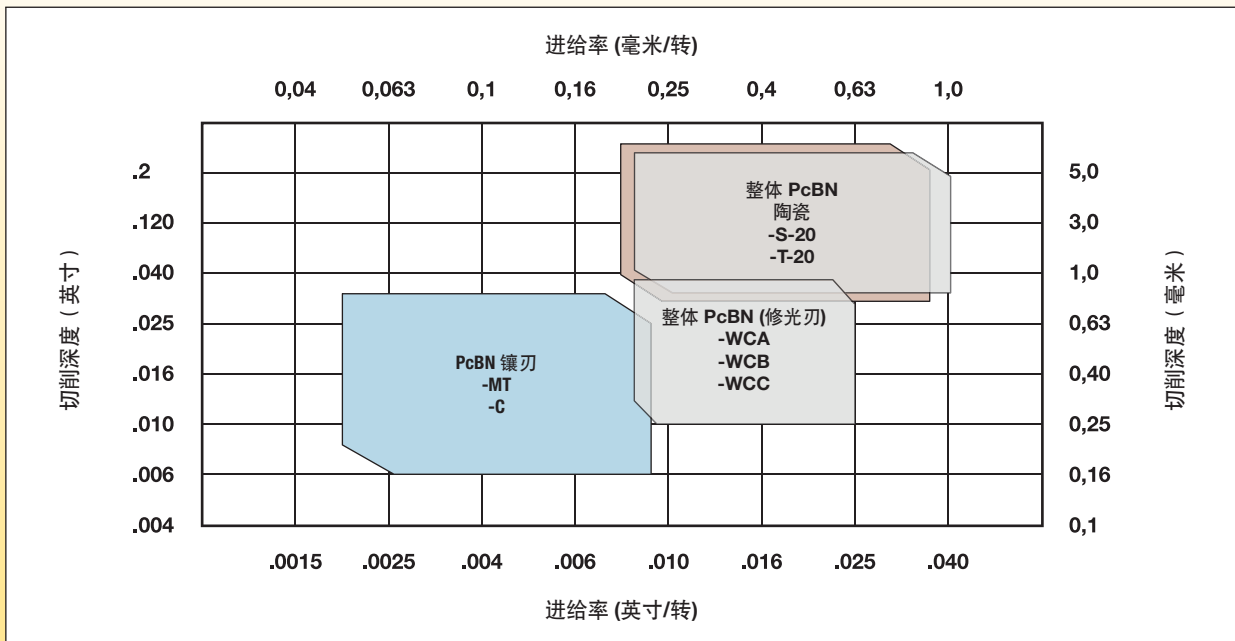

## ■ 中间内凹夹持系统，提高夹持装置稳定性

### 典型应用

因为不断增长的成本压力，生产灰口铸铁制动盘的厂家开始寻求低成本的加工解决方案。CBN 刀片具有更高的生产率，以及更长的刀具寿命。肯纳金属公司开发了整体高含量的 KB1340™ 材质，在对灰口铸铁零件加工时，例如制动盘和飞轮，具有卓越的加工性能。为了确保稳固的刀柄安装性能，刀片采用凹槽夹持设计方案。刀夹装置适合陶瓷刀柄产品，这使得更换肯纳金属刀具产品更加容易。

### 高效率 高收益

- 确保紧密坚固的夹持性能。
- 带有特别夹持性能的凹槽刀片可以增加刀片在刀窝内的稳定性。
- 特别适合重型加工。
- 在要求情况下，可提供经过电镀处理的夹持装置，这种装置具有预防切屑冲蚀的性能。
- 浅凹槽设计方案使得应用成本较低的 4.76mm (3/16"英寸) 刀片成为可能。
- 圆形凹槽设计可与定制刀具配合使用，这种刀具的夹持方向因为空间限制必须经过补偿。

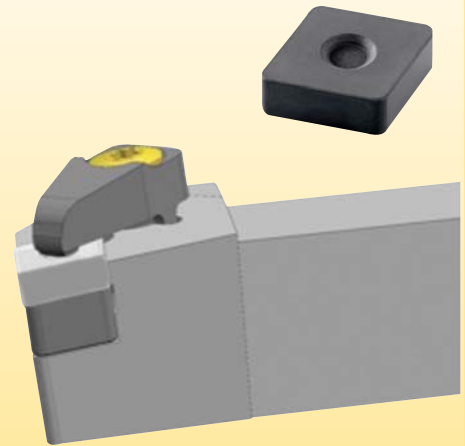

## ■ 夹持装置选择图表

刀片		夹具	
目录编号	目录编号	目录编号	订货号
CNGX433S0415	CNGX120412S01015	551.718-100° Corner	3968904
CNGX433S0415FW	CNGX120412S01015FW	551.718-100° Corner	3968904
CNGX434S0820	CNGX120416S02020	551.718-100° Corner	3968904
CNGF432	CNGF120408	551.718-100° Corner	3968904
DNGX434S0820	DNGX150416S02020	551.720	4094234
SNGX434S0820	SNGX120416S02020	551.718	3968904
SNGX534S0820	SNGX150416S02020	551.718	3968904
VNGX333S0820	VNGX160412S02020	551.721	4094236
TNGX333EFW	TNGX160412EFW	551.733	4094235

## ■ 用于铸铁材料加工的修光刃

### WCA

用于铸铁材料加工的修光刃，进给率可达  $f = 0,25$  毫米/转。

### WCB

用于铸铁材料加工的修光刃，进给率可达  $f = 0,45$  毫米/转。

### WCC

用于铸铁材料加工的修光刃，进给率可达  $f = 0,65$  毫米/转。

ISO 车削刀具

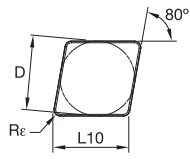
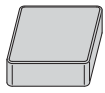

● 首选  
○ 备选

P			
M			
K	●	●	
N			
S			○
H		○	●

■ CNGN

目录编号	D	L10	Re	KBK45	KB1340
CNGN090408T02020	9,53	9,67	0,8	●	-
CNGN090412S02020	9,53	9,67	1,2	●	-
CNGN120408T02020	12,70	12,90	0,8	●	-
CNGN120412S02020	12,70	12,90	1,2	●	-
CNGN120416S02020	12,70	12,90	1,6	●	-

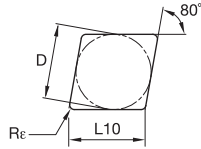
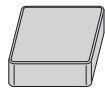

■ CNMN

目录编号	D	L10	Re	KBK45	KB1340
CNMN120408S02020	12,70	12,90	0,8	-	●
CNMN120412S02020	12,70	12,90	1,2	-	●

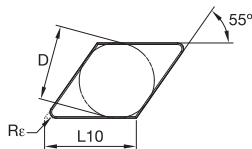
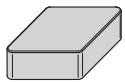

■ DNGN

目录编号	D	L10	Re	KBK45	KB1340
DNGN120408S02020	10,00	12,21	0,8	●	-
DNGN120412S02020	10,00	12,21	1,2	●	-

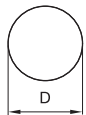

■ RNGN

目录编号	D	L10	Re	KBK45	KB1340
RNGN090400S02020	9,53	-	-	●	-
RNGN120400S02020	12,70	-	-	●	-

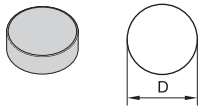

■ RNMN

- 首选
- 备选

P	■	■	■
M	■	■	■
K	■	●	●
N	■	■	■
S	■	○	○
H	■	○	●
		KBK45	KB1340

目录编号	D	L10	Re	KBK45	KB1340
RNMN090300S02020	9,53	—	—	—	●
RNMN120300S02020	12,70	—	—	—	●
RNMN120400S02020	12,70	—	—	—	●

Kendex™ 正前角刀片

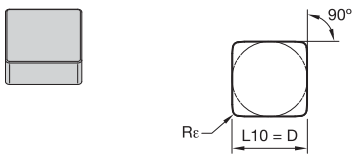

■ SNGN

- 首选
- 备选

P	■	■	■
M	■	■	■
K	■	●	●
N	■	■	■
S	■	○	○
H	■	○	●
		KBK45	KB1340

目录编号	D	L10	Re	KBK45	KB1340
SNGN120408T02020	12,70	12,70	0,8	●	—
SNGN120412S02020	12,70	12,70	1,2	●	—
SNGN120416S02020	12,70	12,70	1,6	●	—

Kendex™ 正角修光刃刀片

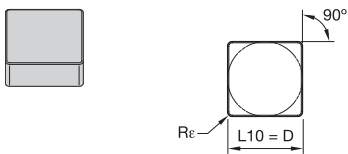

■ SNGN-WCB

- 首选
- 备选

P	■	■	■
M	■	■	■
K	■	●	●
N	■	■	■
S	■	○	○
H	■	○	●
		KBK45	KB1340

目录编号	D	L10	Re	KBK45	KB1340
SNGN090408S01015WCB	9,53	9,52	0,8	●	—

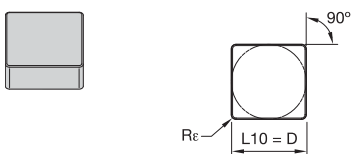

■ SNGN-WCC

目录编号	D	L10	Re	KBK45	KB1340
SNGN090408S01015WCC	9,53	9,53	0,8	●	—

ISO 车削刀具

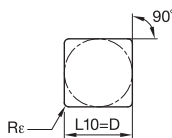

● 首选  
○ 备选

P	■	■	■
M	■	■	■
K	■	●	●
N	■	■	■
S	■	○	○
H	■	○	●

■ SNMN

目录编号	D	L10	Rr	KBK45	KB1340
SNMN090308S02020	9,53	9,53	0,8	-	●
SNMN090316S02020	9,53	9,53	1,6	-	●
SNMN120316S02020	12,70	12,70	1,6	-	●
SNMN120416T02020	12,70	12,70	1,6	-	●

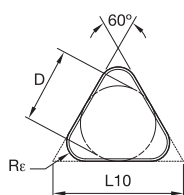

■ TNGN

目录编号	D	L10	Rr	KBK45	KB1340
TNGN110416S02020	6,35	11,00	1,6	●	-
TNGN160416S02020	9,53	16,50	1,6	●	-

Kendex™ 负前角凹槽型刀片

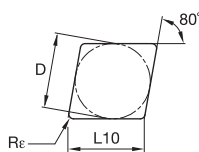
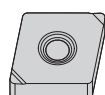

● 首选  
○ 备选

P	■	■	■
M	■	■	■
K	■	●	●
N	■	■	■
S	■	○	○
H	■	○	●

■ CNGF

目录编号	D	L10	Rr	KBK45	KB1340
CNGF120408	12,70	12,90	0,8	-	●



P	■	■	■
M	■	■	■
K	■	●	●
N	■	■	■
S	■	○	○
H	■	○	●

● 首选  
○ 备选

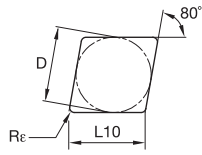

■ CNGX

目录编号	D	L10	Rε	KBK45	KB1340
CNGX120408T02020	12,70	12,90	0,8	●	-
CNGX120412S01015	12,70	12,90	1,2	-	●
CNGX120412S02020	12,70	12,90	1,2	●	-
CNGX120416S02020	12,70	12,90	1,6	●	●

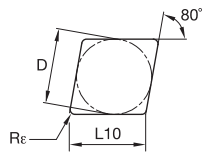
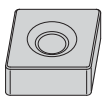

■ CNGX-FW

目录编号	D	L10	Rε	KBK45	KB1340
CNGX120412S01015FW	12,70	12,90	1,2	-	●

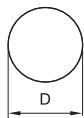
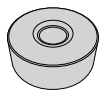

■ RNGX

目录编号	D	L10	Rε	KBK45	KB1340
RNGX120400S02020	12,70	-	-	●	-

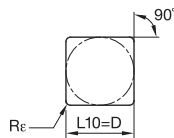

■ SNGX

目录编号	D	L10	Rε	KBK45	KB1340
SNGX120408T02020	12,70	12,70	0,8	●	-
SNGX120412S02020	12,70	12,70	1,2	●	-
SNGX120416S02020	12,70	12,70	1,6	●	●

ISO 车削刀具

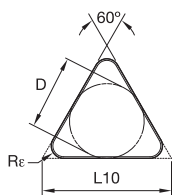
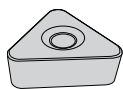

● 首选  
○ 备选

P	■	■	■
M	■	■	■
K	■	●	●
N	■	■	■
S	■	○	○
H	■	○	●

■ TNGX

目录编号	D	L10	Re	KBK45	KB1340
TNGX160416S02020	9,53	16,50	1,6	●	-

Kendex™ 正角刀片

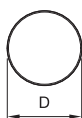
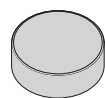

● 首选  
○ 备选

P	■	■	■
M	■	■	■
K	■	●	●
N	■	■	■
S	■	○	○
H	■	○	●

■ RCGN

目录编号	D	L10	Re	KBK45	KB1340
RCGN090400T01015	9,53	-	-	●	-

Kendex™ 负角修光刃刀片

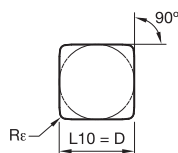

● 首选  
○ 备选

P	■	■	■
M	■	■	■
K	■	●	●
N	■	■	■
S	■	○	○
H	■	○	●

■ SCGN-WCB

目录编号	D	L10	Re	KBK45	KB1340
SCGN090408S01015WCB	9,53	9,52	0,8	●	-

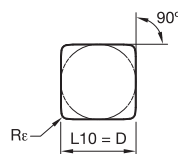

■ SCGN-WCC

目录编号	D	L10	Re	KBK45	KB1340
SCGN090408S01015WCC	9,53	9,52	0,8	●	-



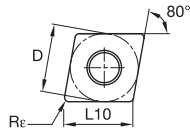
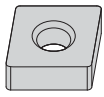

- 首选
- 备选

P	■	■	■
M	■	■	■
K	■	●	●
N	■	■	■
S	■	○	○
H	■	○	●

### ■ CNMA

目录编号	D	L10	Rε	KBK45	KB1340
CNMA120408S02020	12,70	12,90	0,8	-	●
CNMA120412S02020	12,70	12,90	1,2	-	●

注: 刀杆和刀镗杆, 请见 B58-B73.

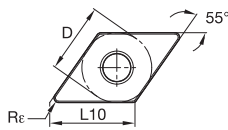
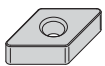

### ■ DNMA

目录编号	D	L10	Rε	KBK45	KB1340
DNMA110408S02020	9,53	11,63	0,8	-	●
DNMA110412S02020	9,53	11,63	1,2	-	●

注: 刀杆和刀镗杆, 请见 B85-B93.

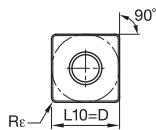

### ■ SNMA

目录编号	D	L10	Rε	KBK45	KB1340
SNMA120412S02020	12,70	12,70	1,2	-	●

注: 刀杆和刀镗杆, 请见 B105-B121.

## 先进材料刀片 • 硬车削材料Kenloc™ 刀片

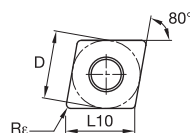

- 首选
- 备选

P	■	■	■
M	■	■	■
K	■	●	●
N	■	■	■
S	■	○	○
H	■	●	●

### ■ CNGA-FWMT

目录编号	D	L10	Rε	KB1345	KB5630
CNGA120404S01025FWMT	12,70	12,90	0,4	-	●
CNGA120408S01025FWMT	12,70	12,90	0,8	-	●

注: 刀杆和刀镗杆, 请见 B58-B73.

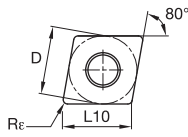

- 首选
- 备选

P	■	■	■
M	■	■	■
K	■	●	●
N	■	■	■
S	■	○	●
H	■	●	●

■ CNGA-MT

目录编号	D	L10	Re	KB1345	KB5630
CNGA120404S01025MT	12,70	12,90	0,4	-	●
CNGA120408S01020MT	12,70	12,90	0,8	●	-
CNGA120408S01025MT	12,70	12,90	0,8	-	●
CNGA120408S02020MT	12,70	12,90	0,8	●	-
CNGA120412S01020MT	12,70	12,90	1,2	-	●
CNGA120412S01025MT	12,70	12,90	1,2	-	●

注: 刀杆和刀镗杆, 请见 B58-B73.

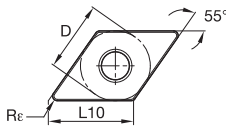
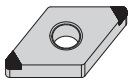

■ DNGA-MT

目录编号	D	L10	Re	KB1345	KB5630
DNGA150404S01025MT	12,70	15,50	0,4	-	●
DNGA150408S01020MT	12,70	15,50	0,8	●	-
DNGA150408S01025MT	12,70	15,50	0,8	-	●

注: 刀杆和刀镗杆, 请见 B85-B93.

先进材料刀片 • 硬车削材料

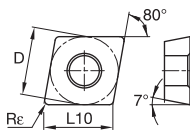

- 首选
- 备选

P	■	■	■
M	■	■	■
K	■	●	●
N	■	■	■
S	■	○	●
H	■	●	●

■ CCGW-C

目录编号	D	L10	Re	KB1345	KB5630
CCGW060202S01015C	6,35	6,45	0,2	-	●
CCGW060204S01015C	6,35	6,45	0,4	-	●
CCGW09T308EC	9,53	9,67	0,8	●	-

注: 刀杆和刀镗杆, 请见 B179-B183.

P	●	●
M	●	●
K	●	●
N	○	●
S	○	●
H	●	●

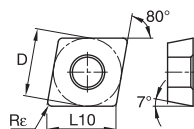

- 首选
- 备选

### ■ CCGW-MT

目录编号	D	L10	Re	KB1345	KB5630
CCGW09T304S01015MT	9,53	9,67	0,4	-	●
CCGW09T308S01015MT	9,53	9,67	0,8	-	●

注: 刀杆和刀镗杆, 请见 B179-B183.

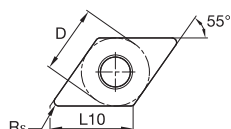
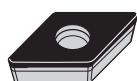

### ■ DCGW-C

目录编号	D	L10	Re	KB1345	KB5630
DCGW070202S01015C	6,35	7,75	0,2	-	●
DCGW070204S01015C	6,35	7,75	0,4	-	●

注: 刀杆和刀镗杆, 请见 B209-B213.

## PcBN 焊刃刀片 • 螺纹接口刀片

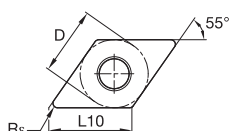
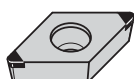

- 首选
- 备选

### ■ DCGW-MT

目录编号	D	L10	Re	KB1345	KB5630
DCGW11T304S01015MT	9,53	11,63	0,4	●	●
DCGW11T308S01015MT	9,53	11,63	0,8	●	●

注: 刀杆和刀镗杆, 请见 B209-B213.

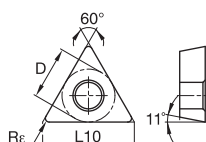

### ■ TPGW-C

目录编号	D	L10	Re	KB1345	KB5630
TPGW110204EC	6,35	11,00	0,4	●	-
TPGW110208S01015C	6,35	11,00	0,8	-	●

注: 刀杆和刀镗杆, 请见 B257-B263.

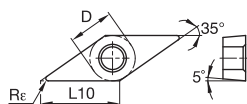
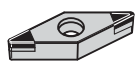

- 首选
- 备选

P	■		
M	■		
K	■	●	●
N	■		
S	■	○	●
H	■	●	●

■ VBGW-MT

目录编号	D	L10	Rε	KB1345	KB5630
VBGW160404S01015MT	9,53	16,61	0,4	-	●
VBGW160408S01015MT	9,53	16,61	0,8	-	●

注: 刀杆和刀镗杆, 请见 B266-B269.

Kenloc™ 刀片

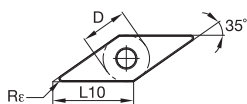
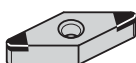

- 首选
- 备选

P	■		
M	■		
K	■	●	●
N	■		
S	■	○	●
H	■	●	●

■ VNGA-MT

目录编号	D	L10	Rε	KB1345	KB5630
VNGA160404S01025MT	9,53	16,61	0,4	-	●
VNGA160408S01025MT	9,53	16,61	0,8	-	●

注: 刀杆和刀镗杆, 请见 B149-B153.

ISO 陶瓷刀片 • Kenloc™ 刀片

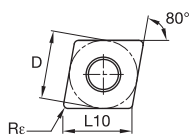

- 首选
- 备选

P	■		
M	■		
K	■	●	●
N	■		
S	■		
H	■		

■ CNGA

目录编号	D	L10	Rε	KYK25	KYK10	KY3500
CNGA120408T02020	12,70	12,90	0,8	●	●	●
CNGA120412T02020	12,70	12,90	1,2	●	●	●
CNGA120416T02020	12,70	12,90	1,6	●	●	●
CNGA160612T02020	15,88	16,12	1,2	●	-	●
CNGA160616T02020	15,88	16,12	1,6	-	-	●
CNGA190612T02020	19,05	19,34	1,2	-	-	●
CNGA190616T02020	19,05	19,34	1,6	●	-	●

注: 刀杆和刀镗杆, 请见 B58-B73.



P	■	■	■
M	■	■	■
K	●	●	●
N	■	■	■
S	■	■	■
H	■	■	■

● 首选  
○ 备选

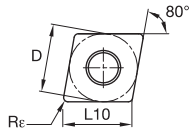

### ■ CNGA-FW

目录编号	D	L10	Rε	KYK25	KYK10	KY3500
CNGA120408T01020FW	12,70	12,90	0,8	●	-	●
CNGA120412T01020FW	12,70	12,90	1,2	●	●	●
CNGA120412T02020FW	12,70	12,90	1,2	-	●	-
CNGA120416T01020FW	12,70	12,90	1,6	-	-	●

注: 刀杆和刀镗杆, 请见 B58-B73.

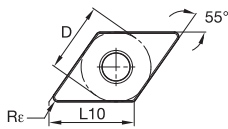
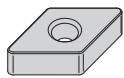

### ■ DNGA

目录编号	D	L10	Rε	KYK25	KYK10	KY3500
DNGA150408T02020	12,70	15,50	0,8	-	-	●
DNGA150412T02020	12,70	15,50	1,2	-	-	●
DNGA150416T02020	12,70	15,50	1,6	●	●	●
DNGA150608T02020	12,70	15,50	0,8	-	-	●
DNGA150612T02020	12,70	15,50	1,2	-	-	●

注: 刀杆和刀镗杆, 请见 B85-B93.

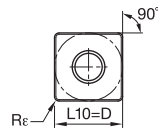

### ■ SNGA

目录编号	D	L10	Rε	KYK25	KYK10	KY3500
SNGA120408T02020	12,70	12,70	0,8	●	●	●
SNGA120412T02020	12,70	12,70	1,2	●	-	●
SNGA120416T02020	12,70	12,70	1,6	-	-	●
SNGA150612T02020	15,88	15,88	1,2	-	-	●
SNGA150612T02020	15,88	15,88	1,2	●	-	-
SNGA150616T02020	15,88	15,88	1,6	-	-	●
SNGA190612T02020	19,05	19,05	1,2	-	-	●

注: 刀杆和刀镗杆, 请见 B105-B121.

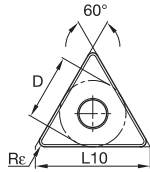
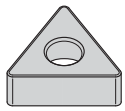

● 首选  
○ 备选

P			
M			
K	●	●	●
N			
S			
H			

■ TNGA

目录编号	D	L10	Re	KYK25	KYK10	KY3500
TNGA160408T02020	9,53	16,50	0,8	-	●	●
TNGA160412T02020	9,53	16,50	1,2	-	●	●
TNGA160416T02020	9,53	16,50	1,6	-	●	●

注: 刀杆和刀镗杆, 请见 B132-B142.

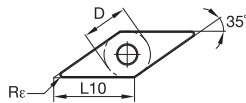
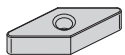

■ VNGA

目录编号	D	L10	Re	KYK25	KYK10	KY3500
VNGA160408T02020	9,53	16,61	0,8	-	-	●
VNGA220408T02020	12,70	22,14	0,8	●	-	-

注: 刀杆和刀镗杆, 请见 B149-B153.

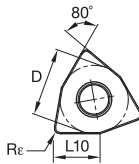
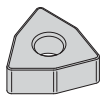

■ WNGA

目录编号	D	L10	Re	KYK25	KYK10	KY3500
WNGA080408T02020	12,70	8,69	0,8	●	-	●
WNGA080412T02020	12,70	8,69	1,2	●	-	●
WNGA080416T02020	12,70	8,69	1,6	-	-	●

注: 刀杆和刀镗杆, 请见 B161-B165.

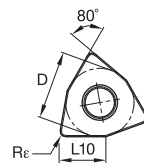
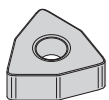

■ WNGA-FW

目录编号	D	L10	Re	KYK25	KYK10	KY3500
WNGA080408T01020FW	12,70	8,69	0,8	-	-	●

注: 刀杆和刀镗杆, 请见 B161-B165.

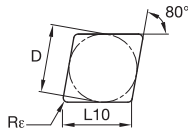

● 首选  
○ 备选

P			
M			
K	●	●	●
N			
S			
H			

■ CNGN

目录编号	D	L10	Rε	KYK25	KYK10	KY3500
CNGN120408T02020	12,70	12,90	0,8	-	-	●
CNGN120412T02020	12,70	12,90	1,2	-	-	●
CNGN120416T02020	12,70	12,90	1,6	-	-	●
CNGN120712T02020	12,70	12,90	1,2	-	-	●
CNGN120716T02020	12,70	12,90	1,6	-	●	-

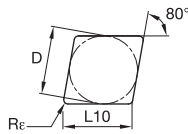
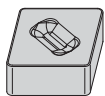

■ CNGX-FW

目录编号	D	L10	Rε	KYK25	KYK10	KY3500
CNGX120708T01020FW	12,70	12,90	0,8	-	-	●
CNGX120712T01020FW	12,70	12,90	1,2	-	-	●
CNGX120716T01020FW	12,70	12,90	1,6	-	-	●

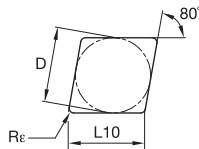

■ CNMX

目录编号	D	L10	Rε	KYK25	KYK10	KY3500
CNMX120708T02020	12,70	12,90	0,8	-	-	●
CNMX120712T02020	12,70	12,90	1,2	-	-	●
CNMX120716T02020	12,70	12,90	1,6	-	-	●

ISO 车削刀具

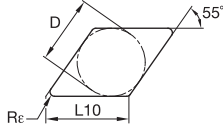
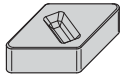

● 首选  
○ 备选

P			
M			
K	●	●	●
N			
S			
H			

■ DNGX

目录编号	D	L10	Rε	KYK25	KYK10	KY3500
DNGX120708T02020	10,00	12,21	0,8	-	-	●
DNGX120712T02020	10,00	12,21	1,2	●	-	●
DNGX120716T02020	10,00	12,21	1,6	-	-	●
DNGX150708T02020	12,70	15,50	0,8	-	-	●
DNGX150712T02020	12,70	15,50	1,2	●	-	●
DNGX150716T02020	12,70	15,50	1,6	-	-	●

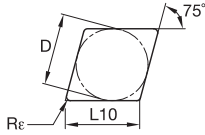

■ ENGX

目录编号	D	L10	Rε	KYK25	KYK10	KY3500
ENGX130716T02020	12,70	13,15	1,6	-	-	●

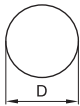

■ RNGN

目录编号	D	L10	Rε	KYK25	KYK10	KY3500
RNGN120400T02020	12,70	-	-	-	●	●
RNGN120700T02020	12,70	-	-	-	●	●
RNGN190700T02020	19,05	-	-	-	-	●



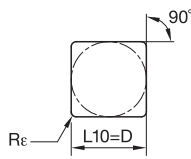

- 首选
- 备选

P			
M			
K	●	●	●
N			
S			
H			

■ SNGN

目录编号	D	L10	Re	KYK25	KYK10	KY3500
SNGN090308T02020	9,53	9,53	0,8	-	-	●
SNGN120408T02020	12,70	12,70	0,8	●	-	●
SNGN120412T02020	12,70	12,70	1,2	●	-	●
SNGN120416T02020	12,70	12,70	1,6	-	-	●
SNGN120432T02020	12,70	12,70	3,2	-	-	●
SNGN120712T02020	12,70	12,70	1,2	●	-	-
SNGN120716T02020	12,70	12,70	1,6	-	-	●
SNGN190416T02020	19,05	19,05	1,6	-	-	●

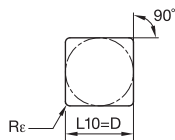

■ SNGX

目录编号	D	L10	Re	KYK25	KYK10	KY3500
SNGX120712T02020	12,70	12,70	1,2	●	●	●
SNGX120716T02020	12,70	12,70	1,6	●	●	●
SNGX150716T02020	15,88	15,88	1,6	-	-	●
SNGX150724T02020	15,88	15,88	2,4	-	-	●

ISO 车削刀具

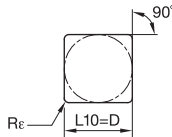

● 首选  
○ 备选

■ SNMX

目录编号	D	L10	Rε	KYK25	KYK10	KY3500
SNMX120712T02020	12,70	12,70	1,2	-	-	●
SNMX120716T02020	12,70	12,70	1,6	-	-	●
SNMX150716T02020	15,88	15,88	1,6	-	-	●

P	■	■	■	■
M	■	■	■	■
K	■	●	●	●
N	■	■	■	■
S	■	■	■	■
H	■	■	■	■

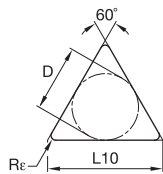
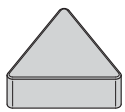

■ TNGN

目录编号	D	L10	Rε	KYK25	KYK10	KY3500
TNGN160408T02020	9,53	16,50	0,8	-	-	●
TNGN220416T02020	12,70	22,00	1,6	-	-	●

KYK25	■	■	■	■
KYK10	■	■	■	■
KY3500	■	■	■	■

Kendex™ 负前角凹槽型刀片

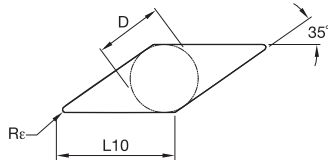
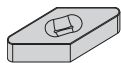

● 首选  
○ 备选

■ VNGX

目录编号	D	L10	Rε	KYK25	KYK10	KY3500
VNGX160712T02020	9,52	16,61	1,2	-	-	●
VNGX160716T02020	9,53	16,61	1,6	-	-	●

P	■	■	■	■
M	■	■	■	■
K	■	●	●	●
N	■	■	■	■
S	■	■	■	■
H	■	■	■	■

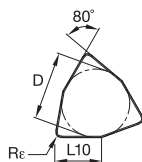

■ WNGX

目录编号	D	L10	Rε	KYK25	KYK10	KY3500
WNGX080712T02020	12,70	8,69	1,2	-	●	●

KYK25	■	■	■	■
KYK10	■	■	■	■
KY3500	■	■	■	■

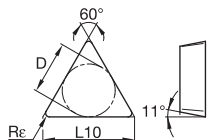
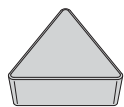

● 首选  
○ 备选

P	■	■	■
M	■	■	■
K	■	●	●
N	■	■	■
S	■	■	■
H	■	■	■

■ TPGN

目录编号	D	L10	Rε	KYK25	KYK10	KY3500
TPGN160308T02020	9,53	16,50	0,8	-	-	●
TPGN160312T02020	9,53	16,50	1,2	-	●	●
TPGN220408T02020	12,70	22,00	0,8	-	-	●
TPGN220412T02020	12,70	22,00	1,2	-	-	●

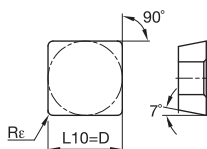
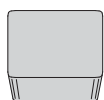

■ SCGN-FW

目录编号	D	L10	Rε	KYK25	KYK10	KY3500
SCGN090408EFW	9,53	9,53	0,8	-	-	●

■ 夹持装置选择图表

订货号	目录编号	夹具	
3960807	CNGX120412S01015	551.718-100° Corner	551.716-80° Corner
3960808	CNGX120412S01015FW	551.718-100° Corner	551.716-80° Corner
3960806	CNGX120416S02020	551.718-100° Corner	551.716-80° Corner
3960811	DNGX150416S02020	551.720	551.720
3960812	SNGX120416S02020	551.718	551.718
3960823	SNGX150416S02020	551.718	551.718
3876843	CNGF120408	551.718-100° Corner	551.716-80° Corner
3960825	TNGX160412EFW	551.733	551.733

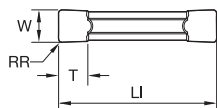
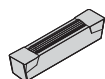

- 首选
- 备选

P	■
M	■
K	●
N	■
S	■
H	■

■ A4G-P-T

目录编号	刀片尺寸	W	RR	LI	T	KY3500
A4G0300M03P04T01025	3	3,00	0,4	20	3,4	●
A4G125I03P1T0425	3	3,18	0,4	20	3,4	●
A4G0400M04P04T01025	4	4,00	0,4	20	3,4	●
A4G0500M05P08T01025	5	5,00	0,8	25	4,2	●
A4G0600M06P08T01025	6	6,00	0,8	30	4,8	●
A4G250I06P2T0425	6	6,35	0,8	30	4,9	●
A4G0800M08P08T01025	8	8,00	0,8	30	6,4	●

注: A4刀杆, 镗刀杆, 刀板请见 C104-C135.

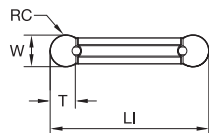
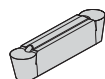

■ A4R-P-T

目录编号	刀片尺寸	W	RC	LI	T	KY3500
A4R0300M03P00T01025	3	3,00	1,5	20	2,4	●
A4R0500M05P00T01025	5	5,00	2,5	25	4,1	●
A4R0600M06P00T01025	6	6,00	3,0	30	4,3	●
A4R250I06P00T0425	6	6,35	3,2	30	4,8	●
A4R0800M08P00T01025	8	8,00	4,0	30	6,4	●

注: A4刀杆, 镗刀杆, 刀板请见 C104-C135.

# 肯纳金属在线服务

kennametal.com

## 查找最近产品信息

无论是车削、铣削，或是孔加工应用，肯纳金属公司都能为您提供高性能的刀具产品，满足您的加工需求。我们为广泛的应用领域提供标准型和定制型产品。

查找我们最近活动及产品目录的信息。

在 Konnect 网站上注册，使用肯纳金属在线订购的全部功能。

## 联系我们

我们注重客户的需求。我们为客户提供行业内最佳的售后服务。如果您有任何意见或问题，请发送给我们。所有的提问，我们将尽可能在 24 小时内回复。

## 在当地查找授权经销商

肯纳金属公司向全球市场提供一流的产品和服务。我们的经销商了解我们，更重要的是，他们还了解客户的需要。与业内其它经销商相比，他们更加了解如何利用肯纳金属公司在全球的技术优势，为客户提供最好的产品和服务。我们的经销商在客户所在行业 and 地区内有更加出色的表现。

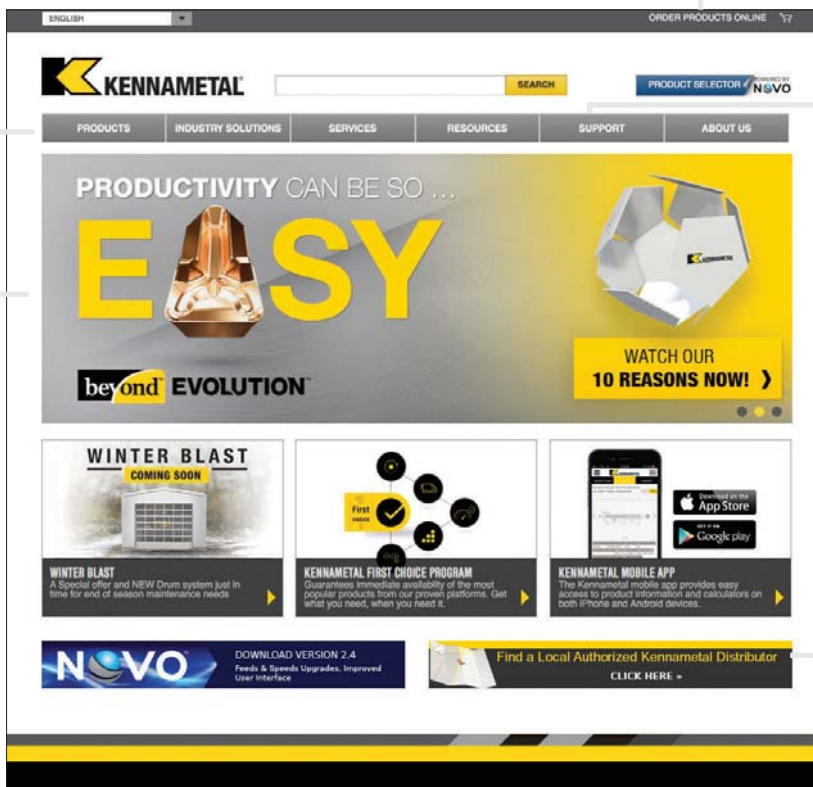

# ► 硬车削刀具

## 高含量和低含量的PcBN刀片产品

目前，全球范围内的金属加工行业开始更多关注高效率，低成本的切削刀具产品。这种行业需求促成了在切削刀具制造过程中，广泛采用超硬材料的发展趋势。正如其名称一样，这些材质与常规材质相比，在硬度方面具有明显的优势。对用户而言，这些优势可以转化成生产率的提高（更高的切削速度、更长的刀具寿命，等），单位工件加工成本的降低，并且可以加工之前采用常规刀具无法加工的材料。

肯纳金属在超硬材料的开发及应用领域位于行业的前沿，在所有系列产品中，包括标准产品和定制产品都采用了超硬材料。我们是根据客户的需要，也是应客户的要求，而在刀具产品的制造过程中开始研发超硬刀具材料。我们于是根据客户的特定需求而开发了最佳性能的超硬刀具产品。



对比而言，PcBN 在大约 1200° C 时仍具有热稳定性，并且具有极佳的耐化学侵蚀性。因此，在硬质黑色金属材料的加工中，或是在其他加工中产生的极端温度不会导致加工的困难，并且可提高自激式热切削加工性能。这将提高技术和生产率优势，特别是与磨削加工相比。在多数情况下，刀具的加工性能要比传统材质刀具具有明显的改善，例如碳化钨和陶瓷材质。

但是，PcBN 刀具在奥氏体钢和铁素体铸铁加工中具有局限性；因为更多的反应相增加了 PcBN 刀具的刃口磨损。

## PcBN 刀片

### KBH10™

大批量加工

- 全新的、具有专利保护的PcBN材质，用于连续切削
- 在低碳硬化钢加工中有出色的表现
- 提供焊尖式及整体式刀片

### KBH20™

高效率 高收益

- 最新开发的基体材料，可确保刀具用于多种苛刻条件下的加工应用。
- 纳米材料涂层可以提高加工速度，并延长刀具寿命。经过改良的刃口处理方式可确保刀具寿命更长，性能更加可靠，加工精度更高，工件公差等级更高。
- 型号齐全的标准产品系列。
- CB1 断屑槽具有正前角和负前角槽型，具有良好的断屑和切屑控制性能。



### KB5630™

- 苛刻切削条件及严重断续切削加工的最佳选择。
- 卓越的耐磨性能。
- PVD 涂层确保更好的热障效果，减少月牙洼磨损，延长刀具寿命。
- 在硬钢材料和粉末金属材料加工中具有卓越的性能。
- 提供焊刃型和整面 PcBN 刀片。



## 陶瓷刀片

### KY1615

小批量加工，灵活性强

- 混合陶瓷（黑色）。
- 卓越的耐磨性以及优秀的韧性。
- 在硬钢和铁基材料的精加工和半精加工中具有卓越的性能。

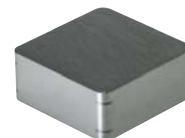



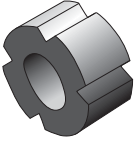
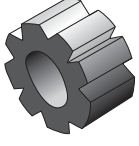

## ■ 刀具测试信息

	材质	尖角型	轻型切削刃口 公制 英制	标准型切削刃口 公制 英制	重型切削刃口 公制 英制
	KBH10*	E	10 15 04 15	12 25 05 25	定制
	KBH20*	定制	10 15 04 15	12 25 05 25	17 35 07 35
	KB5630***	定制	定制	10 25 04 25	17 35 07 35

- ⬆
- ✘ 月牙洼磨损
- ✔ 崩刃
- ✔ 断裂
- ✔ 稳定性
- ⬆
- ✔ 月牙洼磨损
- ✘ 崩刃
- ✔ 断裂
- ✘ 稳定性
- ⬇

注: KBH20™ 刀片和 1225 (0525 为英制) 刀片为初始测试的首选刀片。  
 在精密调整中, 请继续使用相同材质刀片, 但在轻型切削加工中可以使用尖角型刀片, 获胜在断续切削和振动情况下使用重型刀片。  
 如果 KBH20 刀片失效, 请更换为耐磨性更好的材质, 或抗断裂性能更好的材质。  
 \*韧性差  
 \*\*韧性一般  
 \*\*\*韧性好

E = 倒圆  
 T = 带角度的 T 型倒棱  
 S = 带角度和倒圆的 T 型倒棱

举例: S01015 是一个 100 微米的 T 型倒棱, 角度为 15 度, 带倒圆。

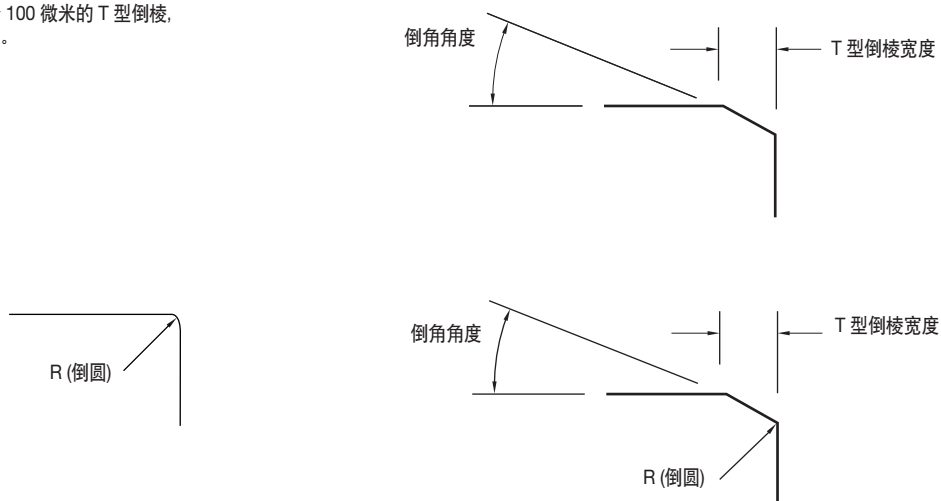

### 步骤一 • 选择刀片槽型

负前角修光刃刀片

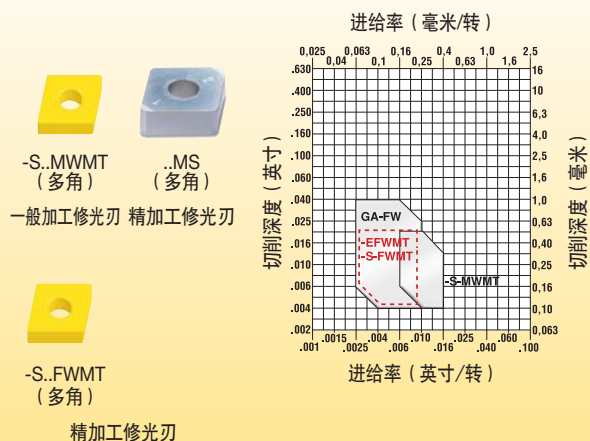

正前角修光刃刀片

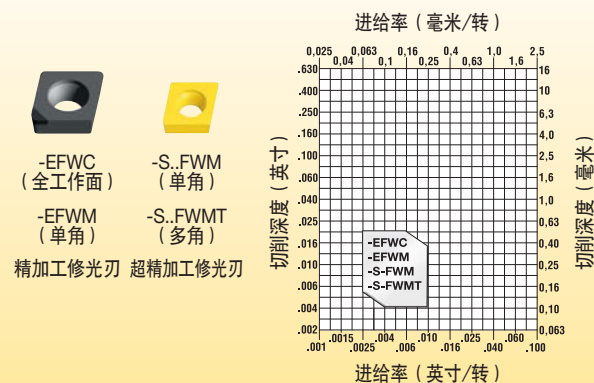

### 步骤二 • 选择刀片材质

工况条件	负前角刀片槽型			正前角刀片槽型		
	-S..FWMT	-EFWMT	-S..FWM	-S..FWM -S..FWMT	-EFWM -EFC	
重型断续切削	KB5630	KB1625	-	-	-	-
轻微断续切削	KB5630/KBH20	KB5625	KBH20	KBH20	KBH20	KBH20
变深切削, 铸造, 或锻造表皮	KBH20	KB1610/KBH10	KBH20	KBH20	KBH20	KBH20
平滑切削, 预车削表面	KBH10	KBH10	KBH10	KBH10	KBH10	KBH10

### 步骤一 • 选择刀片槽型

负前角修光刃刀片

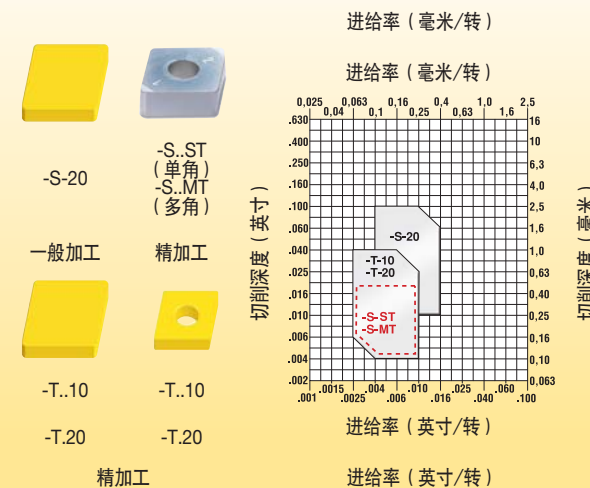

正前角修光刃刀片

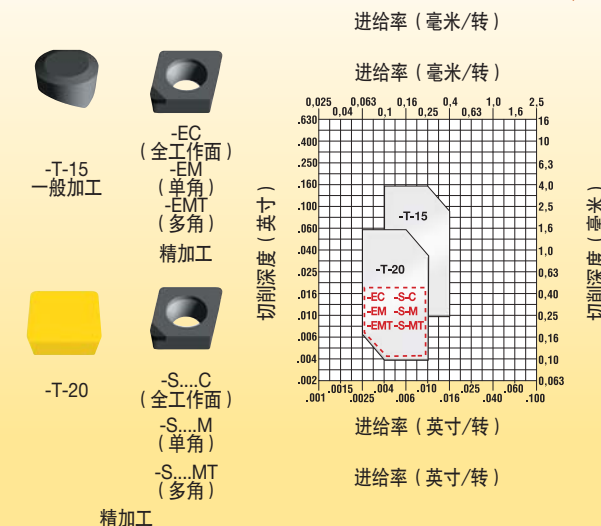

### 步骤二 • 选择刀片材质

工况条件	负前角刀片槽型		正前角刀片槽型
	-T..10 -T..20		-T-15
重型断续切削		-	-
轻微断续切削		-	KY1615
变深切削, 铸造, 或锻造表皮		KY1615	KY1615
平滑切削, 预车削表面		KY1615	KY1615

### ■ 步骤1 • 选择切削速度

材料组	材质	切削速度 - m/min ( SFM )										初始条件	
		15 (50)	45 (150)	75 (250)	110 (350)	140 (450)	170 (550)	200 (650)	230 (750)	260 (850)	m/min	SFM	
H1	KBH20											155	510
	KB5610											150	490
	KB5630											105	345
	KY1615											100	325

### ■ 负倒棱宽度

例一：如果进给率、切削深度、以及刀尖半径等参数已经确定，可以使用这些参数选择恰当的负倒棱宽度。

例二：如果你想使用一个特定宽度的负倒棱或是仅倒圆刀刃，使用以下图表，了解对应不同刀尖半径的推荐最大进给率和切削深度

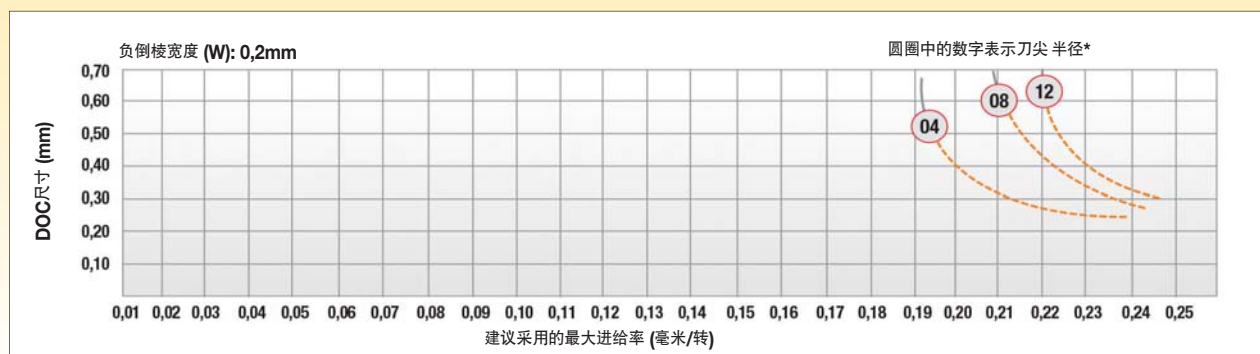
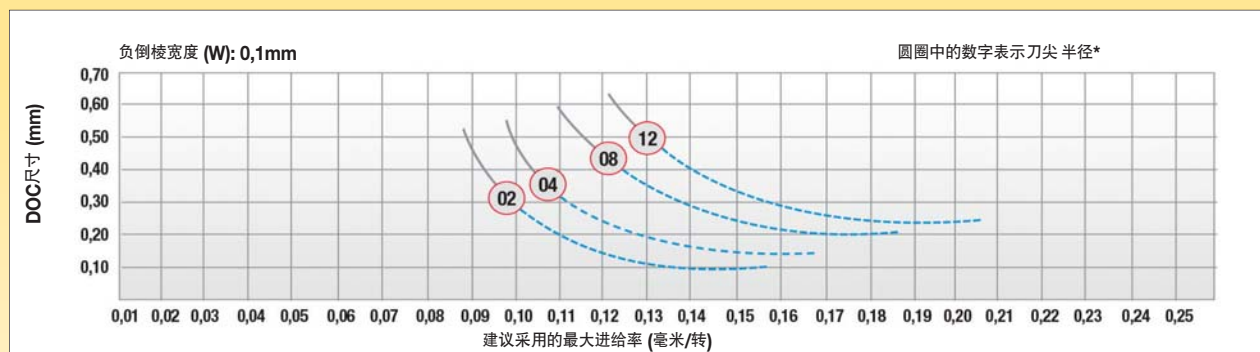
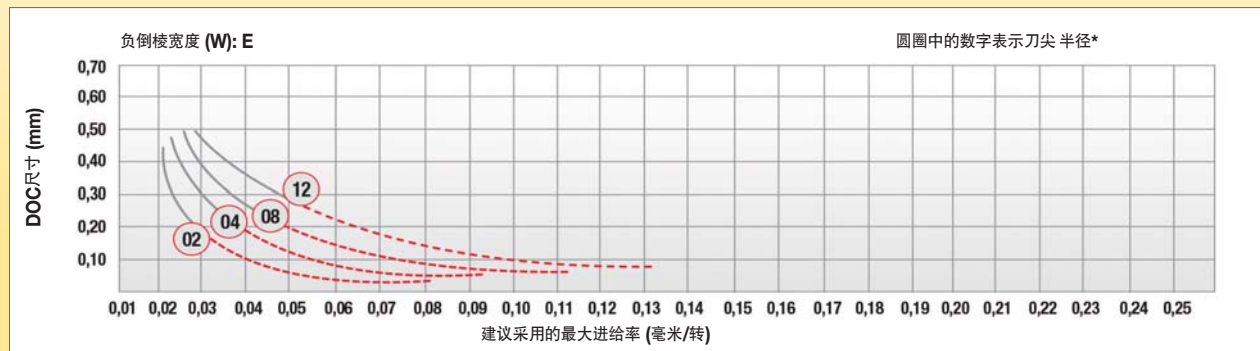
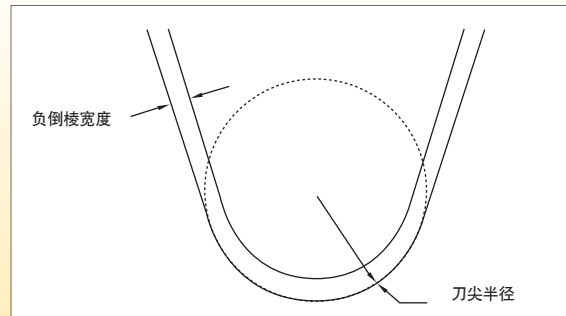

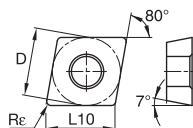
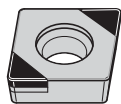

● 首选  
○ 备选

P	●				●
M	●				
K	●				●
N	●				
S	●				●
H	●	●	●	●	●

■ CCGM

目录编号	D	L10	Rε	KBH10	KBH20	KB5630	KY1615
CCGM09T304S01325MTCB1	9,53	9,67	0,4	-	●	-	-
CCGM09T308S01325MTCB1	9,53	9,67	0,8	-	●	-	-

注: 刀杆和刀镗杆, 请见 B179-B183.

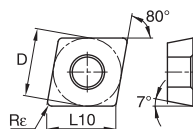

■ CCGW-C

目录编号	D	L10	Rε	KBH10	KBH20	KB5630	KY1615
CCGW060202S01015C	6,35	6,45	0,2	-	-	●	-
CCGW060204S01015C	6,35	6,45	0,4	-	-	●	-

注: 刀杆和刀镗杆, 请见 B179-B183.

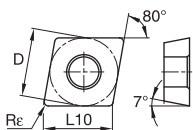
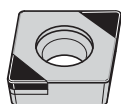

■ CCGW-FWMT

目录编号	D	L10	Rε	KBH10	KBH20	KB5630	KY1615
CCGW09T304S01015FWMT	9,53	9,67	0,4	-	●	-	-
CCGW09T308S01015FWMT	9,53	9,67	0,8	●	●	-	-

注: 刀杆和刀镗杆, 请见 B179-B183.

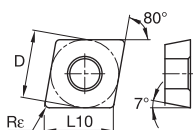
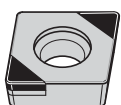

■ CCGW-MT

目录编号	D	L10	Rε	KBH10	KBH20	KB5630	KY1615
CCGW060202S01015MT	6,35	6,45	0,2	●	-	-	-
CCGW060202S01225MT	6,35	6,45	0,2	-	●	-	-
CCGW060204S01015MT	6,35	6,45	0,4	●	-	-	-
CCGW060204S01225MT	6,35	6,45	0,4	-	●	-	-
CCGW09T302S01015MT	9,53	9,67	0,2	●	-	-	-
CCGW09T302S01225MT	9,53	9,67	0,2	-	●	-	-
CCGW09T304S01015MT	9,53	9,67	0,4	●	●	●	-
CCGW09T304S01225MT	9,53	9,67	0,4	●	●	-	-
CCGW09T308S01015MT	9,53	9,67	0,8	●	●	●	-
CCGW09T308S01225MT	9,53	9,67	0,8	●	●	-	-
CCGW120408S01015MT	12,70	12,90	0,8	-	●	-	-

注: 刀杆和刀镗杆, 请见 B179-B183.

P	●				●
M	●				
K	●				●
N	●				
S	●				●
H	●	●	●	●	●

● 首选  
○ 备选

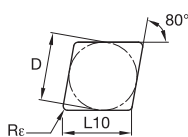

### ■ CNGN

目录编号	D	L10	Rε	KBH10	KBH20	KB5630	KY1615
CNGN120404T02020	12,70	12,90	0,4	-	-	-	●
CNGN120408T02020	12,70	12,90	0,8	-	-	-	●
CNGN120708T02020	12,70	12,90	0,8	-	-	-	●
CNGN120412T02020	12,70	12,90	1,2	-	-	-	●
CNGN120712T02020	12,70	12,90	1,2	-	-	-	●
CNGN120716T02020	12,70	12,90	1,6	-	-	-	●
CNGN160716T02020	15,88	16,12	1,6	-	-	-	●
CNGN160716T05015	15,88	16,12	1,6	-	-	-	●

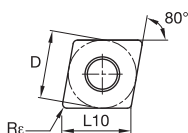
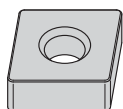

### ■ CNGA

目录编号	D	L10	Rε	KBH10	KBH20	KB5630	KY1615
CNGA120404T02020	12,70	12,90	0,4	-	-	-	●
CNGA120408T00520	12,70	12,90	0,8	-	-	-	●
CNGA120408T02020	12,70	12,90	0,8	-	-	-	●
CNGA120412T02020	12,70	12,90	1,2	-	-	-	●
CNGA120416T02020	12,70	12,90	1,6	-	-	-	●
CNGA160612T02020	15,88	16,12	1,2	-	-	-	●
CNGA190612T02020	19,05	19,34	1,2	-	-	-	●
CNGA190616T02020	19,05	19,34	1,6	-	-	-	●

注: 刀杆和刀镗杆, 请见 B58-B73.

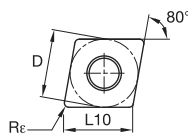
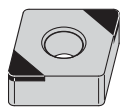

● 首选  
○ 备选

P	●				●
M	●				
K	●				●
N	●				
S	●				●
H	●	●	●	●	●

### ■ CNGA-FWMT

目录编号	D	L10	Re	KBH10	KBH20	KB5630	KY1615
CNGA120404S01015FWMT	12,70	12,90	0,4	●	●	-	-
CNGA120404S01025FWMT	12,70	12,90	0,4	-	-	●	-
CNGA120408S01015FWMT	12,70	12,90	0,8	●	●	-	-
CNGA120408S01025FWMT	12,70	12,90	0,8	-	-	●	-
CNGA120408S01225FWMT	12,70	12,90	0,8	●	●	-	-
CNGA120412S01015FWMT	12,70	12,90	1,2	-	-	-	-
CNGA120412S01225FWMT	12,70	12,90	1,2	●	-	-	-

注: 刀杆和刀镗杆, 请见 B58-B73.

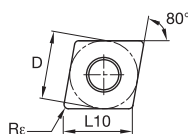
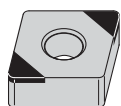

### ■ CNGA-MT

目录编号	D	L10	Re	KBH10	KBH20	KB5630	KY1615
CNGA120404S01015MT	12,70	12,90	0,4	●	●	-	-
CNGA120404S01025MT	12,70	12,90	0,4	-	-	●	-
CNGA120404S01225MT	12,70	12,90	0,4	-	●	-	-
CNGA120404S01735MT	12,70	12,90	0,4	-	●	-	-
CNGA120408S01015MT	12,70	12,90	0,8	●	●	-	-
CNGA120408S01025MT	12,70	12,90	0,8	-	-	●	-
CNGA120408S01225MT	12,70	12,90	0,8	●	●	-	-
CNGA120408S01735MT	12,70	12,90	0,8	●	●	-	-
CNGA120412S01015MT	12,70	12,90	1,2	●	●	-	-
CNGA120412S01020MT	12,70	12,90	1,2	-	-	●	-
CNGA120412S01025MT	12,70	12,90	1,2	-	-	●	-
CNGA120412S01225MT	12,70	12,90	1,2	●	●	-	-
CNGA120412S01735MT	12,70	12,90	1,2	●	●	-	-

注: 刀杆和刀镗杆, 请见 B58-B73.

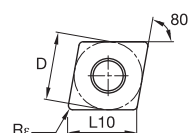
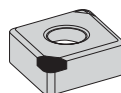

### ■ CNGM-CB1

目录编号	D	L10	Re	KBH10	KBH20	KB5630	KY1615
CNGM120404S01325MTCB1	12,70	12,90	0,4	-	●	-	-
CNGM120408S01325MTCB1	12,70	12,90	0,8	-	●	-	-
CNGM120412S01325MTCB1	12,70	12,90	1,2	-	●	-	-

注: 刀杆和刀镗杆, 请见 B58-B73.

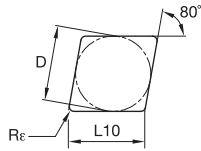
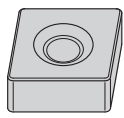

● 首选  
○ 备选

P	●			●
M	●			●
K	●			●
N	●			●
S	●			●
H	●	●	●	●

■ CNGX

目录编号	D	L10	Rε	KBH10	KBH20	KB5630	KY1615
CNGX120708T02020	12,70	12,90	0,8	-	-	-	●
CNGX120712T02020	12,70	12,90	1,2	-	-	-	●

注: 刀杆和刀镗杆, 请见 B58-B73.

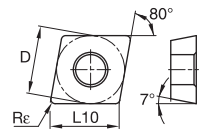
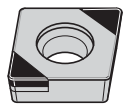

■ CPGW-MT

目录编号	D	L10	Rε	KBH10	KBH20	KB5630	KY1615
CPGW09T304S01015MT	9,53	9,67	0,4	-	-	●	-
CPGW09T308S01015MT	9,53	9,67	0,8	-	-	●	-

注: 刀杆和刀镗杆, 请见 B192-B205.

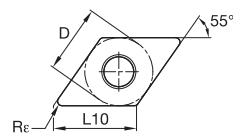
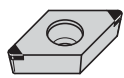

■ DCGM

目录编号	D	L10	Rε	KBH10	KBH20	KB5630	KY1615
DCGM11T304S01325MTCB1	9,53	11,63	0,4	-	●	-	-

注: 刀杆和刀镗杆, 请见 B209-B213.

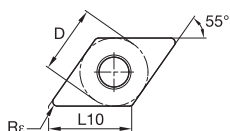
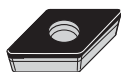

● 首选  
○ 备选

P	●				
M	●				
K	●				
N	●				
S	●				
H	●	●	●	●	●

■ DCGW-C

目录编号	D	L10	Rε	KBH10	KBH20	KB5630	KY1615
DCGW070202S01015C	6,35	7,75	0,2	-	-	●	-
DCGW070204S01015C	6,35	7,75	0,4	-	-	●	-

注: 刀杆和刀镗杆, 请见 B209-B213.

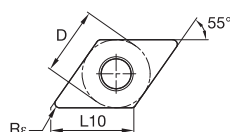
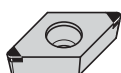

■ DCGW-FWMT

目录编号	D	L10	Rε	KBH10	KBH20	KB5630	KY1615
DCGW11T308S01015FWMT	9,53	11,63	0,4	●	●	-	-
DCGW11T308S01225FWMT	9,53	11,63	0,4	●	-	-	-

注: 刀杆和刀镗杆, 请见 B209-B213.

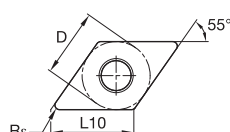
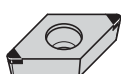

■ DCGW-MT

目录编号	D	L10	Rε	KBH10	KBH20	KB5630	KY1615
DCGW070202S01225MT	6,35	7,75	0,2	-	●	-	-
DCGW070204S01015MT	6,35	7,75	0,4	-	●	-	-
DCGW070204S01225MT	6,35	7,75	0,4	-	●	-	-
DCGW070202S01015MT	6,35	7,75	0,4	●	-	-	-
DCGW070204S01015MT	6,35	7,75	0,4	●	-	-	-
DCGW070204S01225MT	6,35	7,75	0,4	●	-	-	-
DCGW11T302S01015MT	9,53	11,63	0,2	●	-	-	-
DCGW11T302S01225MT	9,53	11,63	0,2	-	●	-	-
DCGW11T304S01225MT	9,53	11,63	0,4	●	●	-	-
DCGW11T304S01015MT	9,53	11,63	0,4	●	●	●	-
DCGW11T308S01015MT	9,53	11,63	0,8	●	●	●	-
DCGW11T308S01225MT	9,53	11,63	0,8	●	●	-	-

注: 刀杆和刀镗杆, 请见 B209-B213.



P	●				●
M	●				
K	●				●
N	●				
S	●				●
H	●	●	●	●	●

● 首选  
○ 备选

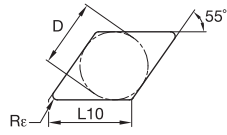
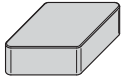

■ DNGN/DNG

目录编号	D	L10	Re	KBH10	KBH20	KB5630	KY1615
DNGN150704T02020	12,70	15,50	0,4	-	-	-	●
DNGN150708T02020	12,70	15,50	0,8	-	-	-	●
DNGN150712T02020	12,70	15,50	1,2	-	-	-	●
DNGN150716T02020	12,70	15,50	1,6	-	-	-	●

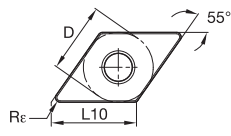
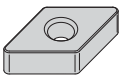

■ DNGA

目录编号	D	L10	Re	KBH10	KBH20	KB5630	KY1615
DNGA150404T02020	12,70	15,50	0,4	-	-	-	●
DNGA150604T02020	12,70	15,50	0,4	-	-	-	●
DNGA150408T02020	12,70	15,50	0,8	-	-	-	●
DNGA150608T02020	12,70	15,50	0,8	-	-	-	●
DNGA150412T02020	12,70	15,50	1,2	-	-	-	●
DNGA150612T02020	12,70	15,50	1,2	-	-	-	●
DNGA150416T02020	12,70	15,50	1,6	-	-	-	●

注: 刀杆和刀镗杆, 请见 B85-B93.

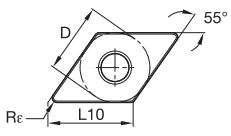
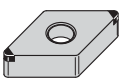

■ DNGA-FWMT

目录编号	D	L10	Re	KBH10	KBH20	KB5630	KY1615
DNGA150408S01015FWMT	12,70	15,50	0,4	●	●	-	-
DNGA150408S01225FWMT	12,70	15,50	0,4	●	●	-	-
DNGA150412S01015FWMT	12,70	15,50	0,8	-	●	-	-
DNGA150412S01225FWMT	12,70	15,50	0,8	●	-	-	-

注: 刀杆和刀镗杆, 请见 B85-B93.

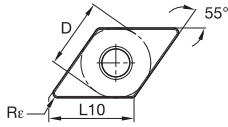
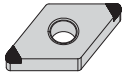

● 首选  
○ 备选

P	●			●
M	●			
K	●		●	
N	●			
S	●		●	
H	●	●	●	●

■ DNGA-MT

目录编号	D	L10	Re	KBH10	KBH20	KB5630	KY1615
DNGA150404S01015MT	12,70	15,50	0,4	●	●	-	-
DNGA150404S01025MT	12,70	15,50	0,4	-	-	●	-
DNGA150404S01225MT	12,70	15,50	0,4	-	●	-	-
DNGA150404S01735MT	12,70	15,50	0,4	-	●	-	-
DNGA150604S01015MT	12,70	15,50	0,4	●	●	-	-
DNGA150604S01225MT	12,70	15,50	0,4	-	●	-	-
DNGA150604S01735MT	12,70	15,50	0,4	-	●	-	-
DNGA150408S01735MT	12,70	15,50	0,8	●	●	-	-
DNGA150408S01015MT	12,70	15,50	0,8	●	●	-	-
DNGA150408S01025MT	12,70	15,50	0,8	-	-	●	-
DNGA150408S01225MT	12,70	15,50	0,8	●	●	-	-
DNGA150608S01015MT	12,70	15,50	0,8	●	●	-	-
DNGA150608S01225MT	12,70	15,50	0,8	●	●	-	-
DNGA150608S01735MT	12,70	15,50	0,8	-	●	-	-
DNGA150412S01015MT	12,70	15,50	1,2	●	●	-	-
DNGA150412S01225MT	12,70	15,50	1,2	●	●	-	-
DNGA150412S01735MT	12,70	15,50	1,2	●	●	-	-
DNGA150612S01015MT	12,70	15,50	1,2	●	●	-	-
DNGA150612S01225MT	12,70	15,50	1,2	●	●	-	-
DNGA150612S01735MT	12,70	15,50	1,2	-	●	-	-

注: 刀杆和刀镗杆, 请见 B85-B93.

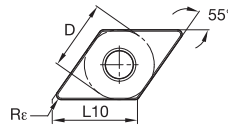
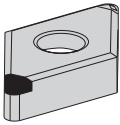

■ DNGM-CB1

目录编号	D	L10	Re	KBH10	KBH20	KB5630	KY1615
DNGM150408S01325MTCB1	12,70	15,50	0,8	-	●	-	-
DNGM150412S01325MTCB1	12,70	15,50	1,2	-	●	-	-
DNGM150608S01325MTCB1	12,70	15,50	0,8	-	●	-	-
DNGM150612S01325MTCB1	12,70	15,50	1,2	-	●	-	-

注: 刀杆和刀镗杆, 请见 B85-B93.

P	●				●
M	●				
K	●				●
N	●				
S	●				●
H	●	●	●	●	●

● 首选  
○ 备选

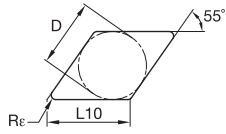
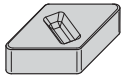

■ DNGX

目录编号	D	L10	Rε	KBH10	KBH20	KB5630	KY1615
DNGX150708T02020	12,70	15,50	0,8	-	-	-	●

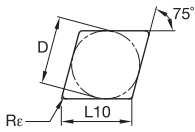
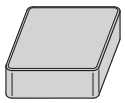

■ ENGN

目录编号	D	L10	Rε	KBH10	KBH20	KB5630	KY1615
ENGN130704T02020	12,70	13,15	0,4	-	-	-	●
ENGN130708T02020	12,70	13,15	0,8	-	-	-	●
ENGN130712T02020	12,70	13,15	1,2	-	-	-	●
ENGN130716T02020	12,70	13,15	1,6	-	-	-	●

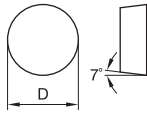
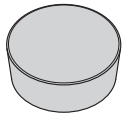

■ RCGX

目录编号	D	L10	Rε	KBH10	KBH20	KB5630	KY1615
RCGX090700T01020	9,53	-	-	-	-	-	●
RCGX090700T02020	9,53	-	-	-	-	-	●
RCGX090700T10015	9,53	-	-	-	-	-	●
RCGX090700T20015	9,53	-	-	-	-	-	●
RCGX120700T02020	12,70	-	-	-	-	-	●
RCGX120700T10015	12,70	-	-	-	-	-	●
RCGX120700T20015	12,70	-	-	-	-	-	●
RCGX151000T20015	15,88	-	-	-	-	-	●
RCGX191000T20015	19,05	-	-	-	-	-	●
RCGX251200T20015	25,40	-	-	-	-	-	●

ISO 车削刀具

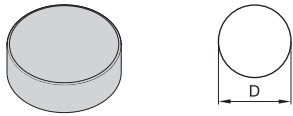

■ RCGW-T

目录编号	D	L10	R <sub>ε</sub>	KBH10	KBH20	KB5630	KY1615
RCGW1204M0T01020	12,00	—	—	—	—	—	●

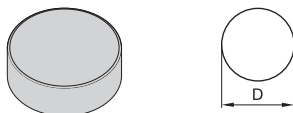

■ RCGX

目录编号	D	L10	R <sub>ε</sub>	KBH10	KBH20	KB5630	KY1615
RCGX0907-001	9,53	—	—	—	—	—	●

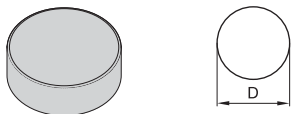

■ RNGN

目录编号	D	L10	R <sub>ε</sub>	KBH10	KBH20	KB5630	KY1615
RNGN090300T02020	9,53	—	—	—	—	—	●
RNGN090400T02020	9,53	—	—	—	—	—	●
RNGN120300T02020	12,70	—	—	—	—	—	●
RNGN120400T02020	12,70	—	—	—	—	—	●
RNGN120700T02020	12,70	—	—	—	—	—	●
RNGN120700T10015	12,70	—	—	—	—	—	●
RNGN120700T20015	12,70	—	—	—	—	—	●
RNGN190700T02020	19,05	—	—	—	—	—	●

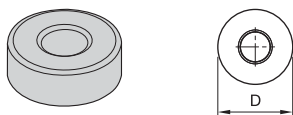

■ RNGA

目录编号	D	L10	R <sub>ε</sub>	KBH10	KBH20	KB5630	KY1615
RNGA090300T02020	9,53	—	—	—	—	—	●
RNGA120400T02020	12,70	—	—	—	—	—	●

注: 刀杆和刀镗杆, 请见 B95.

P	●						
M	●						
K	●						
N	●						
S	●						
H	●	●	●	●	●	●	●

● 首选  
○ 备选

P	●				
M	●				
K	●				
N	●				
S	●				
H	●	●	●	●	●

● 首选  
○ 备选

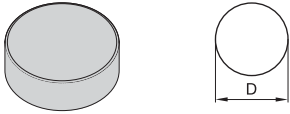

■ RNGN-C

目录编号	D	L10	Rε	KBH10	KBH20	KB5630	KY1615
RNGN090300S02015C	9,53	—	—	—	—	●	—

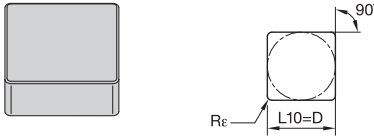

■ SNGN

目录编号	D	L10	Rε	KBH10	KBH20	KB5630	KY1615
SNGN090308T02020	9,53	9,53	0,8	—	—	—	●
SNGN120704T02020	12,70	12,70	0,4	—	—	—	●
SNGN120408T00520	12,70	12,70	0,8	—	—	—	●
SNGN120408T02020	12,70	12,70	0,8	—	—	—	●
SNGN120708T02020	12,70	12,70	0,8	—	—	—	●
SNGN120412T02020	12,70	12,70	1,2	—	—	—	●
SNGN120712T02020	12,70	12,70	1,2	—	—	—	●
SNGN120416T02020	12,70	12,70	1,6	—	—	—	●
SNGN120716T02020	12,70	12,70	1,6	—	—	—	●
SNGN120720T02020	12,70	12,70	2,0	—	—	—	●
SNGN120720T10015	12,70	12,70	2,0	—	—	—	●
SNGN120720T20015	12,70	12,70	2,0	—	—	—	●
SNGN150716T02020	15,88	15,88	1,6	—	—	—	●

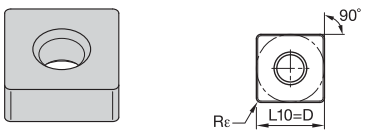

■ SNGA

目录编号	D	L10	Rε	KBH10	KBH20	KB5630	KY1615
SNGA120408T02020	12,70	12,70	0,8	—	—	—	●
SNGA120412T02020	12,70	12,70	1,2	—	—	—	●

注: 刀杆和刀镗杆, 请见 B105-B121.

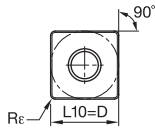
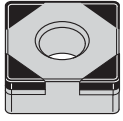

● 首选  
○ 备选

P	●				●
M	●				
K	●				●
N	●				
S	●				●
H	●	●	●	●	●

■ SNGA-MT

目录编号	D	L10	Rε	KBH10	KBH20	KB5630	KY1615
SNGA120408S01015MT	12,70	12,70	0,8	●	-	-	-
SNGA120408S01225MT	12,70	12,70	0,8	●	●	-	-
SNGA120412S01225MT	12,70	12,70	1,2	●	●	-	-

注: 刀杆和刀镗杆, 请见 B105-B121.

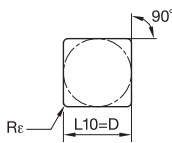
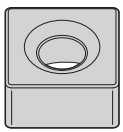

■ SNGX

目录编号	D	L10	Rε	KBH10	KBH20	KB5630	KY1615
SNGX120712T02020	12,70	12,70	1,2	-	-	-	●

注: 刀杆和刀镗杆, 请见 B105-B121.

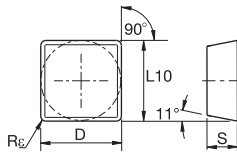
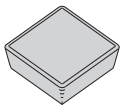

■ SPG-T

目录编号	D	L10	Rε	KBH10	KBH20	KB5630	KY1615
SPGN090308T01020	9,53	9,53	0,8	-	-	-	●
SPGN120308T01020	12,70	12,70	0,8	-	-	-	●

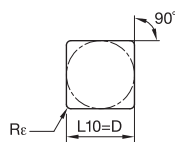
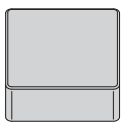

■ SPU-T

目录编号	D	L10	Rε	KBH10	KBH20	KB5630	KY1615
SPUN120308T00520	12,70	12,70	0,8	-	-	-	●

P	●	●	●	●
M	●	●	●	●
K	●	●	●	●
N	●	●	●	●
S	●	●	●	●
H	●	●	●	●

● 首选  
○ 备选

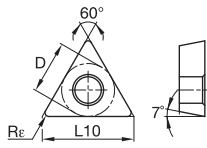

TCGW-MT

目录编号	D	L10	Re	KBH10	KBH20	KB5630	KY1615
TCGW090202S01015MT	5,56	9,62	0,2	-	-	-	-
TCGW090204S01015 MT	5,56	9,62	0,4	-	●	-	-
TCGW110202S01015MT	6,35	11,00	0,2	●	●	-	-
TCGW110204S01015MT	6,35	11,00	0,4	●	●	-	-
TCGW110204S01225MT	6,35	11,00	0,4	●	-	-	-
TCGW110208S01015MT	6,35	11,00	0,8	●	●	-	-
TCGW110208S01225MT	6,35	11,00	0,8	●	-	-	-

注: 刀杆和刀镗杆, 请见 B247-B248.

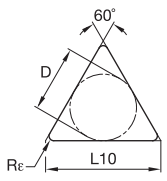
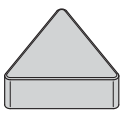

TNGN

目录编号	D	L10	Re	KBH10	KBH20	KB5630	KY1615
TNGN110308T02020	6,35	11,00	0,8	-	-	-	●
TNGN160404T02020	9,53	16,50	0,4	-	-	-	●
TNGN160408T02020	9,53	16,50	0,8	-	-	-	●
TNGN160708T02020	9,53	16,50	0,8	-	-	-	●
TNGN160412T02020	9,53	16,50	1,2	-	-	-	●
TNGN160712T02020	9,53	16,50	1,2	-	-	-	●
TNGN160416T02020	9,53	16,50	1,6	-	-	-	●
TNGN220408T02020	12,70	22,00	0,8	-	-	-	●

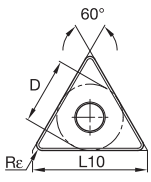
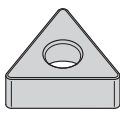

TNGA

目录编号	D	L10	Re	KBH10	KBH20	KB5630	KY1615
TNGA160408T02020	9,53	16,50	0,8	-	-	-	●
TNGA160412T02020	9,53	16,50	1,2	-	-	-	●
TNGA220408T02020	12,70	22,00	0,8	-	-	-	●
TNGA220412T02020	12,70	22,00	1,2	-	-	-	●

注: 刀杆和刀镗杆, 请见 B132-B142.

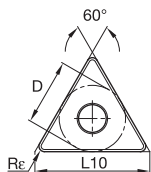
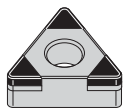

● 首选  
○ 备选

P	●				●
M	●				
K	●				●
N	●				
S	●				●
H	●	●	●	●	●

■ TNGA-MT

目录编号	D	L10	Rε	KBH10	KBH20	KB5630	KY1615
TNGA160404S01015MT	9,53	16,50	0,4	●	●	-	-
TNGA160404S01225MT	9,53	16,50	0,4	-	●	-	-
TNGA160404S01735MT	9,53	16,50	0,4	-	●	-	-
TNGA160408S01015MT	9,53	16,50	0,8	●	●	-	-
TNGA160408S01225MT	9,53	16,50	0,8	●	●	-	-
TNGA160408S01735MT	9,53	16,50	0,8	●	●	-	-
TNGA160412S01015MT	9,53	16,50	1,2	●	●	-	-
TNGA160412S01225MT	9,53	16,50	1,2	●	●	-	-
TNGA160412S01735MT	9,53	16,50	1,2	●	●	-	-

注: 刀杆和刀镗杆, 请见 B132-B142.

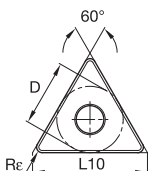

■ TNGM • 一般加工

目录编号	D	L10	Rε	KBH10	KBH20	KB5630	KY1615
TNGM160408S01325MTCB1	9,53	16,50	0,8	-	●	-	-

注: 刀杆和刀镗杆, 请见 B132-B142.

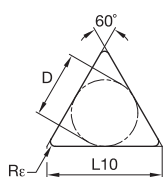
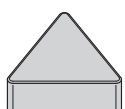

■ TPGN

目录编号	D	L10	Rε	KBH10	KBH20	KB5630	KY1615
TPGN110304T01020	6,35	11,00	0,4	-	-	-	●
TPGN110308T01020	6,35	11,00	0,8	-	-	-	●
TPGN110312T01020	6,35	11,00	1,2	-	-	-	●
TPGN160304T00520	9,53	16,50	0,4	-	-	-	●
TPGN160304T01020	9,53	16,50	0,4	-	-	-	●
TPGN160308T00520	9,53	16,50	0,8	-	-	-	●
TPGN160308T01020	9,53	16,50	0,8	-	-	-	●
TPGN160312T01020	9,53	16,50	1,2	-	-	-	●



P	●				
M	●				
K	●				
N	●				
S	●				
H	●	●	●	●	●

● 首选  
○ 备选

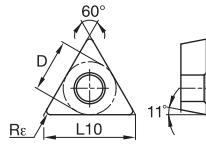

■ TPGW-C

目录编号	D	L10	Rε	KBH10	KBH20	KB5630	KY1615
TPGW110208S01015C	6,35	11,00	0,8	-	-	●	-

注: 刀杆和刀镗杆, 请见 B257-B263.

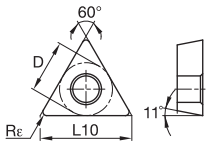

■ TPGW-MT

目录编号	D	L10	Rε	KBH10	KBH20	KB5630	KY1615
TPGW110308S01225MT	6,35	10,96	0,8	●	-	-	-
TPGW110202S01015MT	6,35	11,00	0,2	-	●	-	-
TPGW110304S01015MT	6,35	11,00	0,4	●	-	-	-
TPGW110304S01225MT	6,35	11,00	0,4	●	-	-	-
TPGW110204S01015MT	6,35	11,00	0,4	-	●	-	-
TPGW110208S01015MT	6,35	11,00	0,8	-	●	-	-
TPGW160404S01015MT	9,53	16,50	0,4	●	-	-	-
TPGW160404S01225MT	9,53	16,50	0,4	●	-	-	-
TPGW16T304S01015MT	9,53	16,50	0,4	-	●	-	-
TPGW160408S01015MT	9,53	16,50	0,8	●	-	-	-
TPGW160408S01225MT	9,53	16,50	0,8	●	-	-	-
TPGW16T308S01015MT	9,53	16,50	0,8	-	●	-	-
TPGW16T308S01225MT	9,53	16,50	0,8	-	●	-	-

注: 刀杆和刀镗杆, 请见 B257-B263.

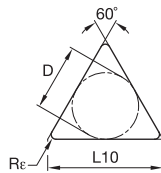
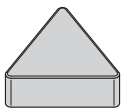

■ TPU-T

目录编号	D	L10	Rε	KBH10	KBH20	KB5630	KY1615
TPUN110304T00520	6,35	11,00	0,4	-	-	-	●
TPUN110308T00520	6,35	11,00	0,8	-	-	-	●
TPUN160304T00520	9,53	16,50	0,4	-	-	-	●
TPUN160308T00520	9,53	16,50	0,8	-	-	-	●
TPUN160312T00520	9,53	16,50	1,2	-	-	-	●

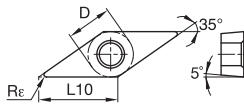
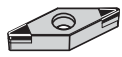

● 首选  
○ 备选

■ VBGW-MT

目录编号	D	L10	Re	KBH10	KBH20	KB5630	KY1615
VBGW110304S01015MT	6,35	11,07	0,4	●	●	-	-
VBGW110304S01225MT	6,35	11,07	0,4	-	●	-	-
VBGW110308S01015MT	6,35	11,07	0,8	●	-	-	-
VBGW110308S01225MT	6,35	11,07	0,8	-	●	-	-
VBGW160404S01015MT	9,53	16,61	0,4	●	●	●	-
VBGW160408S01015MT	9,53	16,61	0,8	●	●	●	-
VBGW160412S01015MT	9,53	16,61	1,2	-	●	-	-

注: 刀杆和刀镗杆, 请见 B266-B269.

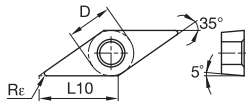
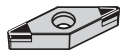

■ VCGW • 轻型加工

目录编号	D	L10	Re	KBH10	KBH20	KB5630	KY1615
VCGW160404S01015MT	9,53	16,61	0,4	-	●	-	-
VCGW160404S01225MT	9,53	16,61	0,4	-	●	-	-
VCGW160408S01015MT	9,53	16,61	0,8	-	●	-	-
VCGW160408S01225MT	9,53	16,61	0,8	-	●	-	-

注: 刀杆和刀镗杆, 请见 B266-B269.

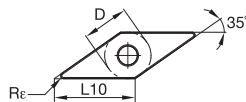
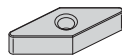

■ VNGA

目录编号	D	L10	Re	KBH10	KBH20	KB5630	KY1615
VNGA160404T02020	9,53	16,61	0,4	-	-	-	●
VNGA160408T02020	9,53	16,61	0,8	-	-	-	●
VNGA160412T02020	9,53	16,61	1,2	-	-	-	●
VNGA220408T02020	12,70	22,14	0,8	-	-	-	●

注: 刀杆和刀镗杆, 请见 B149-B153.

P	●	●	●	●
M	●	●	●	●
K	●	●	●	●
N	●	●	●	●
S	●	●	●	●
H	●	●	●	●

P	●				●
M	●				
K	●				●
N	●				
S	●				●
H	●	●	●	●	●

● 首选  
○ 备选

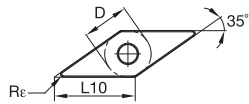
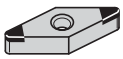

### VNGA-MT

目录编号	D	L10	Rε	KBH10	KBH20	KB5630	KY1615
VNGA160404S01015MT	9,53	16,61	0,4	●	●	-	-
VNGA160404S01025MT	9,53	16,61	0,4	-	-	●	-
VNGA160404S010225MT	9,53	16,61	0,4	●	●	-	-
VNGA160404S01735MT	9,53	16,61	0,4	-	●	-	-
VNGA160408S01015MT	9,53	16,61	0,8	●	●	-	-
VNGA160408S01025MT	9,53	16,61	0,8	-	-	●	-
VNGA160408S01225MT	9,53	16,61	0,8	●	●	-	-
VNGA160408S01735MT	9,53	16,61	0,8	-	●	-	-
VNGA160412S01225MT	9,53	16,61	1,2	-	●	-	-

注: 刀杆和刀镗杆, 请见 B149-B153.

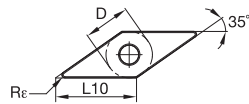
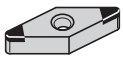

### VNGM

目录编号	D	L10	Rε	KBH10	KBH20	KB5630	KY1615
VNGM160408S01325MTCB1	9,53	16,61	0,8	-	●	-	-
VNGM160412S01325MTCB1	9,53	16,61	1,2	-	●	-	-

注: 刀杆和刀镗杆, 请见 B149-B153.

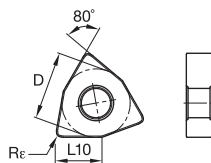
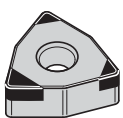

### WNGA

目录编号	D	L10	Rε	KBH10	KBH20	KB5630	KY1615
WNGA080408S01015FWMT	12,70	8,69	0,8	-	●	-	-

注: 刀杆和刀镗杆, 请见 B161-B165.

ISO 车削刀具

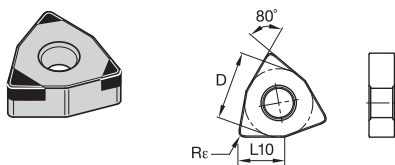

● 首选  
○ 备选

P	■	■	■	●
M	■	■	■	■
K	■	■	■	●
N	■	■	■	■
S	■	■	■	●
H	■	●	●	●

■ WNGA-FWMT

目录编号	D	L10	Re	KBH10	KBH20	KB5630	KY1615
WNGA080408S01015FWHBM	12,70	8,69	0,8	-	●	-	-

注: 刀杆和刀镗杆, 请见 B161-B165.

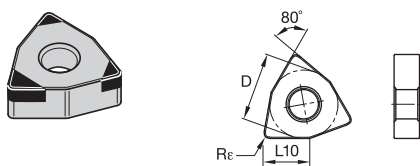

■ WNGA-MT

目录编号	D	L10	Re	KBH10	KBH20	KB5630	KY1615
WNGA080404S01015MT	12,70	8,69	0,4	-	●	-	-
WNGA080408S01015MT	12,70	8,69	0,8	-	●	-	-
WNGA080408S01225MT	12,70	8,69	0,8	-	●	-	-
WNGA080408S01735MT	12,70	8,69	0,8	-	●	-	-
WNGA80408S01015MT	12,70	8,69	0,8	●	-	-	-
WNGA80408S01225MT	12,70	8,69	0,8	●	-	-	-

注: 刀杆和刀镗杆, 请见 B161-B165.

# A4™ 刀具及 Beyond™ 刀片



选择 A4 刀具系统，可用于多种工件材料的车削、端面、切槽、端面切槽，以及切断加工。独特的装夹系统，多样的断屑槽型保证了高效的金属去除率。

## 特点及优势

### A4切槽及车削刀具

- 一款可用于车削、端面加工、切槽、端面切槽、切断，外圆、以及内圆加工的刀具产品 - 可以大幅缩短加工周期，转塔不会出现转位现象。
- 超长的夹持区域，底部120度的棱形支持面，以及具有专利权的顶部导轨设计，使产品在进行切槽和横向车削时具有无以比拟的稳定性。
- 精确的刀片定位性能 - 可用于精确切削加工。
- 即使在加工条件最为苛刻的切削加工中，具有良好刚性的夹具系统仍然可以稳固地锁定刀片。
- 多功能的设计方案，单个刀具系统既可进行外圆、内圆、切槽、端面切槽、背车、根切加工，甚至还可进行螺纹加工。
- 具有切屑控制性能的刀片可在切槽加工中顺利排出切屑，并且在多向车削加工中具有更好的切屑控制性能。

联系肯纳金属授权经销商，或是登录 [kennametal.com](http://kennametal.com)，了解更多的产品优势。



[kennametal.com](http://kennametal.com)

关于PDF内容涉及《广告法》违禁词、极限词用语作废声明  
本PDF文字、图片中涉及《广告法》中违禁词、极限词等词语的，在此申明一律作废，不作为产品介绍的依据。谢谢配合。

# ► 使用陶瓷和 PcBN 刀片加工高温合金材料

肯纳金属公司利用 Beyond™ 技术，并根据加工特点制成的先进材质具有更好的耐磨性和韧性。

KYS 陶瓷刀片是用于高温合金铝材料高速切削加工的首选产品。与未经涂层处理产品相比，复合涂层产品具有更好的化学稳定性和耐磨性。与晶须增强铝基陶瓷材质相比，硅铝氧氮陶瓷基体材质具有更加卓越的抗切深处破损性能。

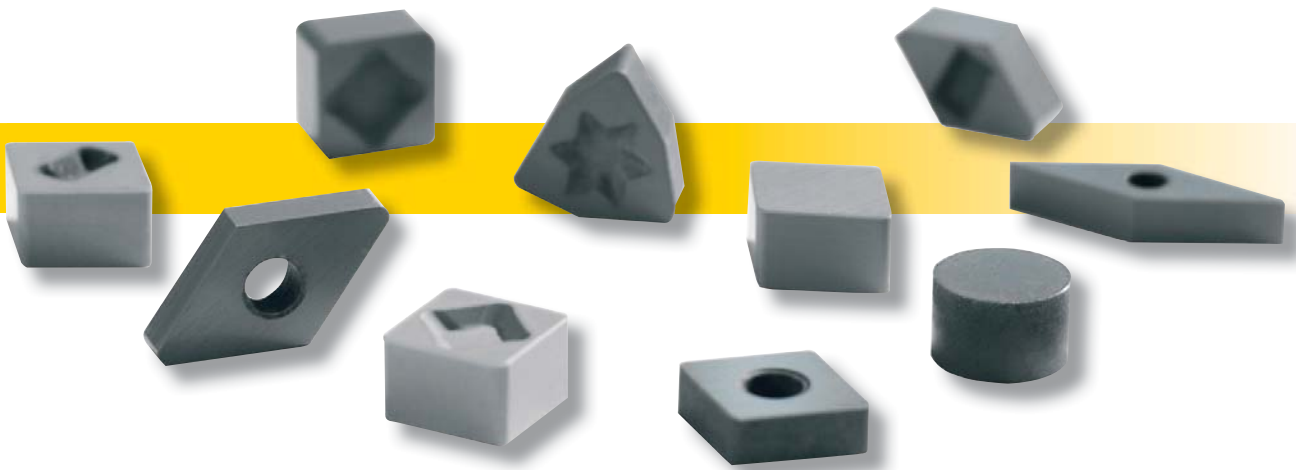

## 陶瓷刀片

### KYS25™

- 卓越的表面光洁度，更低的切削力，更高的切削速度。
- 先进的 CVD 涂层具有卓越的化学稳定性和抗切深处破损性能。

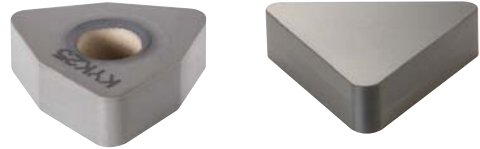

### KYS30™

- 超长的刀具寿命。
- 极佳的韧性和抗切深处破损性能。
- 可用于多种加工工况，包括断续切削和鳞刺工件加工。



## PcBN 焊刃刀片

### KB1630

- 超长的刀具寿命。
- 极佳的韧性和抗切深处破损性能。
- 可用于多种加工工况，包括断续切削和鳞刺工件加工。



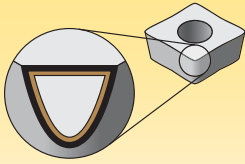

涂层更适合高速加工，并且可用于精加工至轻型粗加工的应用范围。

P	钢
M	不锈钢
K	铸铁
N	非铁金属
S	高温合金
H	硬材料

耐磨性 ←————→ 韧性

涂层		材质说明		05	10	15	20	25	30	35	40	45
陶瓷材质	KYS25	成分: SiAlON陶瓷材质, 涂层为氧化铝TiCN CVD材料。 应用: 作为 KYS30™ 材质的补充, 可对高温合金材料、镍基合金材料、以及高布氏硬度的铸造材料进行加工。与晶须陶瓷材料相比, 这种先进的 CVD 涂层具有卓越的化学性能和抗切深处破损性能。										
陶瓷材质	KYS30	成份: 最新开发的最新型硅铝氧氮聚合材料 (SiAlON)。 应用范围: 具有出色的耐磨性, 抗断裂韧性, 以及抗热冲击性能, 可用于高温合金工件的一般加工至精加工。与晶须陶瓷材料相比, 具有更出色的抗切深处破损的性能。										
PcBN - 立方氮化硼材质	KB1630	成分: 一种非涂层高 PcBN 含量的材质。PcBN 刃口钎焊至硬质合金刀片上。 应用: 用于对硬化钢材料 (硬度大于 45 HRC) 进行断续切削的粗加工至精加工应用。同时还用于灰铸铁、冷硬铁、高铬合金钢、高温合金以及烧结粉末金属材料加工。PcBN 焊刃刀片有多种刀片类型, 包括 Top Notch™ 和螺纹接口槽型。										



## NOVO 查询查询

通过 NOVO™ 的刀具咨询和刀具选择功能查询刀具信息—可节省大量时间和金钱。

### 刀具咨询

NOVO 通过应用一个规则引擎, 可以提供切削刀具推荐方案:

- 确定加工类型 (端面铣削、槽铣、盲孔加工等)。
- 设定限制性要求 (槽型、材料、公差等)。
- 设定加工顺序 (一次或多次走刀, 粗加工后进行精加工等)。
- 获得排序后的查找结果。

### 选择

在树形结构内以层级搜索或参数搜索方式查找刀具产品:

- 如果用户了解自己需要查找的产品, 可以在输入目录编号, 或产品名称的情况下进行快速查找。
- 智能筛选器可将大量不符合筛选条件的刀具产品排除在外。
- 在选定刀具后, NOVO 还可根据您的应用需求提供适用的刀具配件及配套产品。

应用 NOVO 系统, 您可以在正确的时间, 为自己的机床设备选择正确的刀具。从而可以完美地完成整个工艺过程, 缩短加工周期, 提高单班加工效率。 [kenametal.com/novo](http://kenametal.com/novo)

■ 步骤1 • 选择刀片槽型



负前角刀片

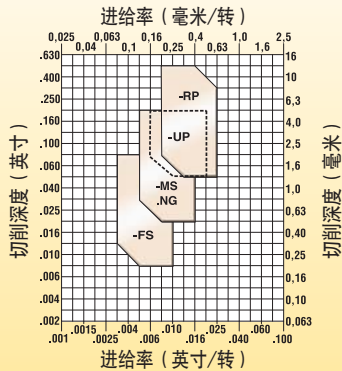

正前角刀片

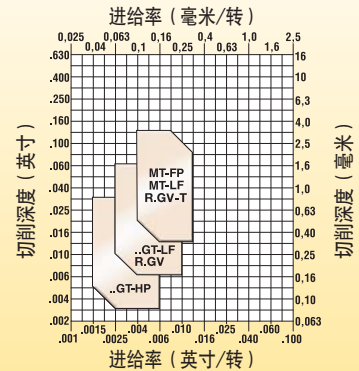

■ 步骤2 • 选择刀片材质

		负前角刀片槽型
工况条件		.NG
重型断续切削		-
轻微断续切削		KYS30/KY1540
变深切削, 铸造, 或锻造表皮		KYS30/KY1540/KYS25/KY4300
平滑切削、预车削表面		KYS25/KY4300

		正前角刀片槽型
工况条件		R.GV-T
重型断续切削		-
轻微断续切削		KYS30/KY1540
变深切削, 铸造, 或锻造表皮		KYS30/KY1540/KYS25/KY4300
平滑切削、预车削表面		KYS25/KY4300

**步骤3 • 选择切削速度**

铁基合金耐热合金 (135-320 HB) (≤34 HRC)

切削速度 - m/min (SFM)

初始条件

材料组	材质	15	45	75	105	140	170	200	230	260	290	310	350	380	m/min	SFM
		(50)	(150)	(250)	(350)	(450)	(550)	(650)	(750)	(850)	(950)	(1050)	(1150)	(1250)		
S1	KB1630	◇												260	850	
	KYS25/KY4300	◇												200	650	
	KYS30/KY1540	◇												170	550	

钴基耐热合金 (150-425 HB) (≤45 HRC)

切削速度 - m/min (SFM)

初始条件

材料组	材质	15	45	75	105	140	170	200	230	260	290	310	350	380	m/min	SFM
		(50)	(150)	(250)	(350)	(450)	(550)	(650)	(750)	(850)	(950)	(1050)	(1150)	(1250)		
S2	KB1630	◇												260	850	
	KYS25/KY4300	◇												220	720	
	KYS30/KY1540	◇												185	600	

镍基耐热合金 (140-475 HB) (≤48 HRC)

切削速度 - m/min (SFM)

初始条件

材料组	材质	15	45	75	105	140	170	200	230	260	290	310	350	380	m/min	SFM
		(50)	(150)	(250)	(350)	(450)	(550)	(650)	(750)	(850)	(950)	(1050)	(1150)	(1250)		
S3	KB1630	◇												260	850	
	KYS25/KY4300	◇												250	820	
	KYS30/KY1540	◇												215	700	

ISO 车削刀具

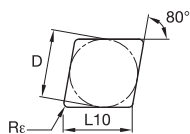
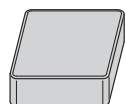

● 首选  
○ 备选

■ CNGN

目录编号	D	L10	Rε		KYS25	KYS30	KB1630
CNGN120416T01020	12,70	12,90	1,6	●	-	-	-
CNGN120712T01020	12,70	12,90	1,2	●	●	-	-
CNGN120716T01020	12,70	12,90	1,6	-	●	-	-

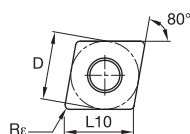
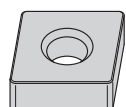

■ CNGA

目录编号	D	L10	Rε		KYS25	KYS30	KB1630
CNGA120408E	12,70	12,90	0,8	●	●	-	-
CNGA120408T01020	12,70	12,90	0,8	●	●	-	-
CNGA120412T01020	12,70	12,90	1,2	●	●	-	-

注: 刀杆和刀镗杆, 请见 B58-B73.

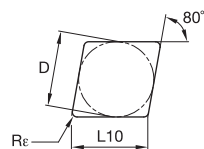
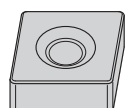

■ CNGX

目录编号	D	L10	Rε		KYS25	KYS30	KB1630
CNGX120708T01020	12,70	12,90	0,8	●	●	-	-
CNGX120712T01020	12,70	12,90	1,2	●	●	-	-
CNGX120716E	12,70	12,90	1,6	-	●	-	-

注: 刀杆和刀镗杆, 请见 B58-B73.

P	●		
M	●		
K	●		
N	●		
S	●	●	○
H	○	●	●

P			
M			
K			
N			
S	●	●	○
H	○		●

● 首选  
○ 备选

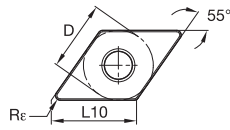
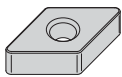

■ DNGA

目录编号	D	L10	Rε	KYS25	KYS30	KB1630
DNGA150408T01020	12,70	15,50	0,8	-	●	-
DNGA150412T01020	12,70	15,50	1,2	-	●	-

注: 刀杆和刀镗杆, 请见 B85-B93.

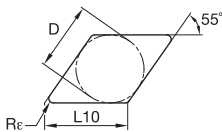
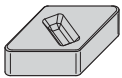

■ DNGX

目录编号	D	L10	Rε	KYS25	KYS30	KB1630
DNGX150708T01020	12,70	15,50	0,8	●	-	-
DNGX150712T01020	12,70	15,50	1,2	●	●	-
DNGX150716T01020	12,70	15,50	1,6	-	●	-

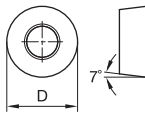
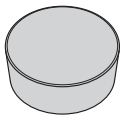

■ RCGX

目录编号	D	L10	Rε	KYS25	KYS30	KB1630
RCGX060400E	6,35	-	-	●	●	-
RCGX090700E	9,53	-	-	●	●	-
RCGX090700T00525	9,53	-	-	-	●	-
RCGX090700T01020	9,53	-	-	●	●	-
RCGX120700E	12,70	-	-	●	●	-
RCGX120700T01020	12,70	-	-	●	●	-
RCGX120700T01025	12,70	-	-	●	●	-

ISO 车削刀具

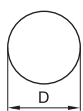
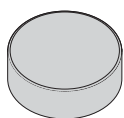

● 首选  
○ 备选

■ RNGN

P			
M			
K			
N			
S	●	●	○
H	○		●

目录编号	D	L10	Rε	KYS25	KYS30	KB1630
RNGN120400T01020	12,70	—	—	—	●	—
RNGN120700T00525	12,70	—	—	—	●	—
RNGN120700T01020	12,70	—	—	—	●	—
RNGN120700T01025	12,70	—	—	●	●	—
RNGN190700T01020	19,05	—	—	—	●	—

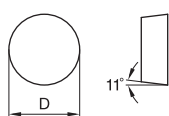
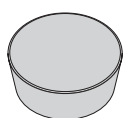

■ RPGN

目录编号	D	L10	Rε	KYS25	KYS30	KB1630
RPGN060200E	6,35	—	—	—	●	—
RPGN090300E	9,53	—	—	—	●	—
RPGN090300T01020	9,53	—	—	—	●	—
RPGN120400E	12,70	—	—	—	●	—
RPGN120400T01020	12,70	—	—	—	●	—

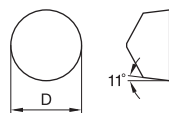
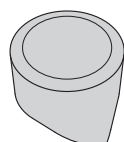

■ RPGX

目录编号	D	L10	Rε	KYS25	KYS30	KB1630
RPGX090700E	9,53	—	—	●	●	—
RPGX090700T01020	9,53	—	—	—	●	—
RPGX120700E	12,70	—	—	●	●	—
RPGX120700T01020	12,70	—	—	—	●	—

P				
M				
K				
N				
S	●	●	○	
H	○		●	

● 首选  
○ 备选

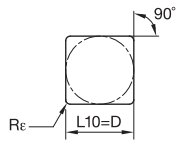
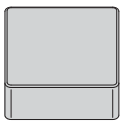

■ SNGN

目录编号	D	L10	Rε	KYS25	KYS30	KB1630
SNGN120408T01020	12,70	12,70	0,8	-	●	-
SNGN120412T01020	12,70	12,70	1,2	-	●	-
SNGN120416T01020	12,70	12,70	1,6	●	●	-
SNGN120716T01020	12,70	12,70	1,6	-	●	-
SNGN190616E	19,05	19,05	1,6	●	-	-
SNGN190616T01020	19,05	19,05	1,6	-	●	-
SNGN190724E	19,05	19,05	2,4	-	●	-

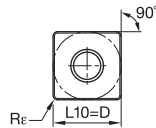
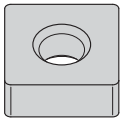

■ SNGA

目录编号	D	L10	Rε	KYS25	KYS30	KB1630
SNGA120412T01020	12,70	12,70	1,2	●	●	-

注: 刀杆和刀镗杆, 请见 B105-B121.

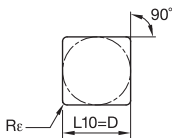
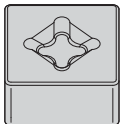

■ SNGX

目录编号	D	L10	Rε	KYS25	KYS30	KB1630
SNGX120712T01020	12,70	12,70	1,2	-	●	-
SNGX120716T01020	12,70	12,70	1,6	-	●	-

ISO 车削刀具

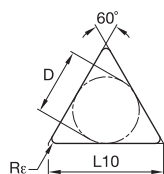
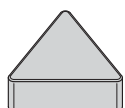

● 首选  
○ 备选

■ TNGN

目录编号	D	L10	Rε		KYS25	KYS30	KB1630
TNGN220412T01020	12,70	22,00	1,2	●	-	-	-
TNGN220416T01020	12,70	22,00	1,6	●	-	-	-

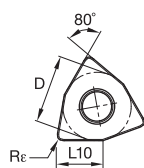
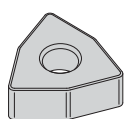

■ WNGA

目录编号	D	L10	Rε		KYS25	KYS30	KB1630
WNGA080408T01020	12,70	8,69	0,8	-	●	-	-
WNGA080416T01020	12,70	8,69	1,6	-	●	-	-

注: 刀杆和刀镗杆, 请见 B161-B165.

P	■	■	■
M	■	■	■
K	■	■	■
N	■	■	■
S	●	●	○
H	○	○	●



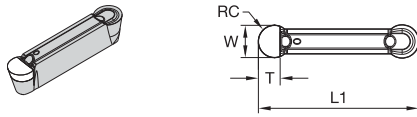

● 首选  
○ 备选

■ 平板圆角精磨 • PcBN

目录编号	刀片尺寸	W	RC	LI	T	KCU10	KCU25	KCP10	KCP25	KCK20	K313	KC5010	KC5025	KY3500	KT315	KB1630	KB5625	KD1405	
A4R0300M03P00EST	3	3,00	1,5	20	2,2	-	-	-	-	-	-	-	-	-	-	-	-	-	-
A4R0400M04P00EST	4	4,00	2,0	20	2,9	-	-	-	-	-	-	-	-	-	-	-	-	-	-
A4R0500M05P00EST	5	5,00	2,5	25	3,7	-	-	-	-	-	-	-	-	-	-	-	-	-	-
A4R0600M06P00EST	6	6,00	3,0	30	4,4	-	-	-	-	-	-	-	-	-	-	-	-	-	-

注: A4刀杆, 镗刀杆, 刀板请见 C104-C135.

P	●	●	●	○	○	○	○	○	○	○	○	○	○	○	○	○	○	○	○
M	●	●	○	○	○	○	○	○	○	○	○	○	○	○	○	○	○	○	○
K	○	○	○	○	○	○	○	○	○	○	○	○	○	○	○	○	○	○	○
N	●	○	○	○	○	○	○	○	○	○	○	○	○	○	○	○	○	○	○
S	●	●	○	○	○	○	○	○	○	○	○	○	○	○	○	○	○	○	○
H	○	○	○	○	○	○	○	○	○	○	○	○	○	○	○	○	○	○	○

ISO 车削刀具

# 多晶金刚石刀片



## 多晶金刚石 (PCD) 刀片

- 用于高温合金材料的加工，以及非铁金属材料的特定加工。
- 与硬质合金刀片相比具有显著的硬度优势。
- 更高的切削速度和更长的刀具寿命，因此可提高生产率。
- 在常规刀具无法加工的材料应用中具有极佳的性能。

### KD1400™

- 特别适合非铁材料的通用车削加工。
- 用于较低硅含量至适当硅含量的铝合金材料、非金属材料、铜、以及铜合金和锌合金材料的加工。
- 卓越的抗机械冲击性能。
- 可用于多种连续切削和断续切削，同时可用于对表面精度有极高要求的加工应用。



### KD1405™

- 肯纳金属公司生产的，在非铁材料和非金属材料的加工中抗磨损性能最好的刀具材质。
- 用于对耐磨损性能有较高要求的应用。
- CVD金刚石材质。



### KD1425™

- 产品设计具有极佳的耐磨性。
- 在苛刻条件下的应用中具有良好的刃口强度。
- 一种用于高硅铝合金材料、双金属材料、碳纤维强化分子化合物塑料、以及其它高磨损非金属材料加工的理想材质。



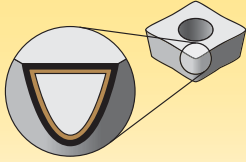

涂层更适合高速加工，并且可用于精加工至轻型粗加工的应用范围。

P	钢
M	不锈钢
K	铸铁
N	非铁金属
S	高温合金
H	硬材料

耐磨性 ←————→ 韧性

PCD — 多晶金刚石材质

涂层	材质说明		05	10	15	20	25	30	35	40	45
KD1400	成分：一种超细晶粒的多晶金刚石（PCD）镶刃硬质合金刀片。 应用：主要用于非铁材料的通用车削加工。可以用于多种连续切削和断续切削，同时对表面精加工质量有极高要求的加工。用于较低硅含量至适当硅含量的铝合金材料、非金属材料、铜、以及铜合金和锌合金材料的加工。超细的金刚石晶粒粒度具有卓越的表面精加工质量，同时在各种 PCD 切削刀具产品中，具有最佳的抗机械冲击性能。										
KD1405	成分：一种将纯 CVD 材料熔敷至金刚石片上的材质，并直接钎焊至硬质合金材料的基体上。 应用：KD1405™ 是肯纳金属公司研发的抗磨损性能最佳的刀具材质，可用于非铁材料和非金属材料的加工。特别适合对耐磨性要求极高的加工应用。										
KD1425	成分：一种多尺度分布的PCD细晶粒材质，具有多种晶粒粒度，并钎焊至硬质合金基体上。 应用：具有极好的耐磨性，以及良好的刀刃强度，可用于苛刻条件的加工应用。一种用于高硅铝合金材料、双金属材料（AL/GCI）、MMC、碳纤维强化分子化合物塑料、以及其它高磨损非金属材料加工的理想材质。										

# Beyond™ PVD 材质

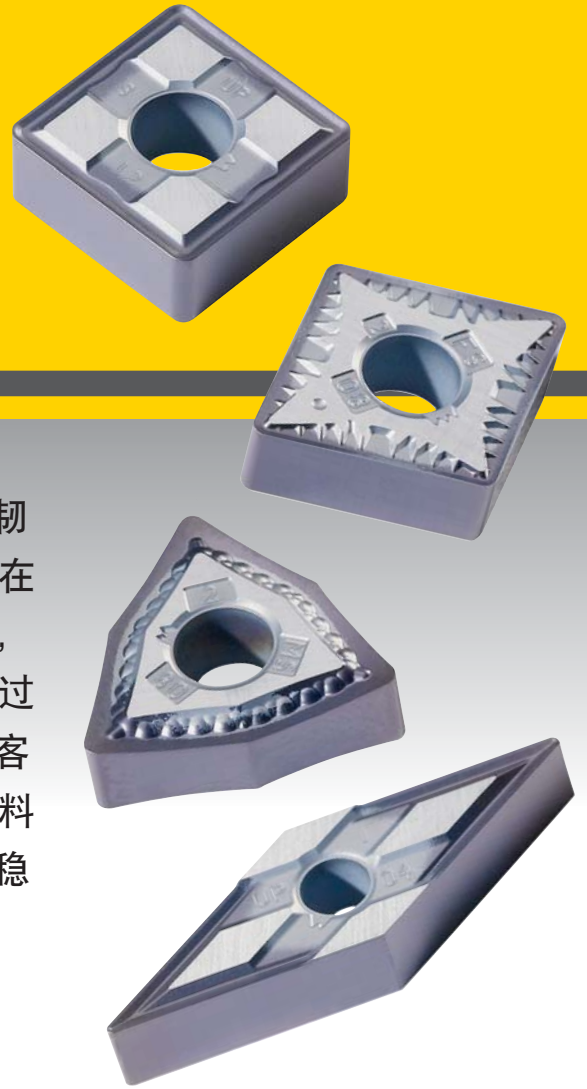

Beyond™ 高级 PVD 涂层非常适合容易导致高温的韧性材料加工。这些涂层产品可延长刀具寿命，在通用加工行业、交通行业、航天工业、能源行业，以及筑路与采矿行业都可提高客户的生产率。通过利用Beyond PVD 涂层以及产品型号齐全的优势，客户可在车削、切槽、以及切断加工，以及多种材料的加工中应用这些产品。Beyond PVD 涂层有助于稳定的切屑控制性能，并见到刀片刃口的磨损。

beyond

## KCU10™

- PVD 涂层材质具有卓越的抗磨损性能。用于精加工至一般加工。
- 用于各种材料加工，特别适合不锈钢及高温合金工件的加工。

## KCU25™

- 具有良好刀刃韧性和耐磨性的 PVD 涂层刀片。一般加工至粗加工应用
- 可用于各种材料加工。

联系肯纳金属授权经销商，或是登录 [kennametal.com](http://kennametal.com)，了解更多的产品优势。



[kennametal.com](http://kennametal.com)

关于PDF内容涉及《广告法》违禁词、极限词用语作废声明  
本PDF文字、图片中涉及《广告法》中违禁词、极限词等词语的，在此申明一律作废，不作为产品介绍的依据。谢谢配合。

### 步骤一 • 选择刀片槽型

负前角刀片

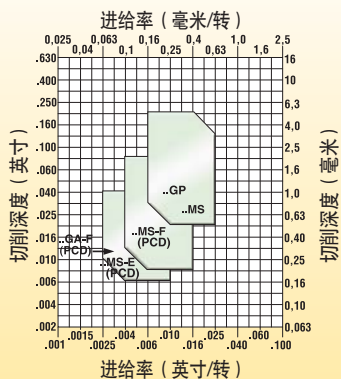

正前角刀片

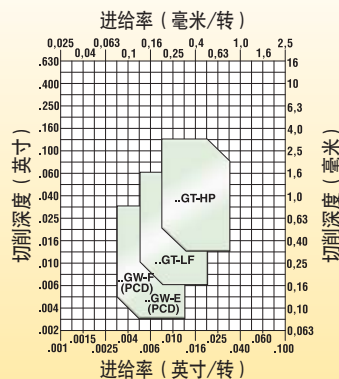
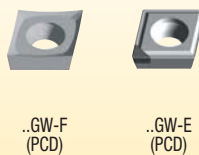

### 步骤二 • 选择刀片材质

工况条件	负前角刀片槽型			正前角刀片槽型	
	..GA-E (PCD)	..MS-E (PCD)	..GA-F (PCD)	..GW-E (PCD)	..GW-F (PCD)
重型断续切削	-	-	KD1400	-	KD1400
轻微断续切削	KD1405	KD1405	KD1400	KD1405	KD1400
变深切削, 铸造, 或锻造表皮	KD1405	KD1405	KD1425	KD1405	KD1425
平滑切削, 预车削表面	KD1405	KD1405	KD1425	KD1405	KD1425

### 步骤三 • 选择切削速度

低硅铝合金  
(亚共晶体<12.2% Si) 和 锰合金

材料组	材质	切削速度 - m/min (SFM)										初始条件	
		250 (800)	500 (1600)	750 (2400)	1000 (3200)	1250 (4000)	1500 (4800)	1750 (5600)	2000 (6400)	2250 (7200)	2500 (8000)	m/min	SFM
N1	KD1400	◇										765	2500

低硅铝合金  
(亚共晶体>12.2% Si) 和 锰合金

材料组	材质	切削速度 - m/min (SFM)				初始条件	
		250 (800)	500 (1600)	750 (2400)	1000 (3200)	m/min	SFM
N3	KD1405	◇				550	1800
	KD1425	◇				765	2500

### ■ 其它工件材料的推荐切削速度

机械加工性能指数范围 70-100 内的铜基材料、黄铜基材料和锌基材料

切削速度 - m/min (SFM)

初始条件



材料组	材质	250 (800)	500 (1600)	750 (2400)	1000 (3200)	m/min	SFM
N4	KD1400/KD1405	◇				520	1700
	KD1425	◇				500	1600

尼龙、塑料、橡胶、酚醛塑料、树脂、玻璃纤维、玻璃

切削速度 - m/min (SFM)

初始条件



材料组	材质	250 (800)	500 (1600)	750 (2400)	1000 (3200)	m/min	SFM
N5	KD1400/KD1405	◇				400	1300
	KD1425	◇				365	1200

碳及石墨复合材料:

铍铜合金、凯夫拉尔纤维, 以及石墨 (280-400 HB) (30-43 HRC)

切削速度 - m/min (SFM)

初始条件



材料组	材质	250 (800)	500 (1600)	750 (2400)	1000 (3200)	m/min	SFM
N6	KD1400/KD1405	◇				760	2500

MMCs (铝基复合材料)

切削速度 - m/min (SFM)

初始条件



材料组	材质	250 (800)	500 (1600)	750 (2400)	1000 (3200)	m/min	SFM
N7	KD1405	◇				460	1500
	KD1400	◇				365	1200

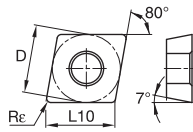
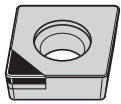

● 首选  
○ 备选

P			
M			
K			
N	●	○	●
S		●	●
H			

■ CCGW-FST

目录编号	D	L10	Rε	KD1400	KD1405	KD1425
CCGW060204FST	6,35	6,45	0,4	●	-	●
CCGW09T304FST	9,53	9,67	0,4	●	-	●
CCGW09T308FST	9,53	9,67	0,8	●	-	●

注: 刀杆和刀镗杆, 请见 B179-B183.

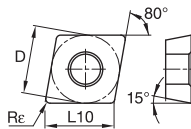
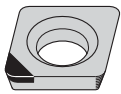

■ CDHB-FST

目录编号	D	L10	Rε	KD1400	KD1405	KD1425
CDHBS4T002FST	3,97	4,03	0,2	●	-	●
CDHBS4T0X0FST	3,97	4,03	0,1	●	-	-

注: 刀杆和刀镗杆, 请见 B185-B187.

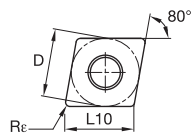
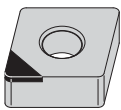

■ CNGA

目录编号	D	L10	Rε	KD1400	KD1405	KD1425
CNGA120404E	12,70	12,90	0,4	-	●	-
CNGA120408E	12,70	12,90	0,8	-	●	-

注: 刀杆和刀镗杆, 请见 B58-B73.

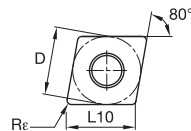
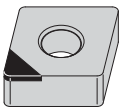

■ CNGA-FST

目录编号	D	L10	Rε	KD1400	KD1405	KD1425
CNGA120404FST	12,70	12,90	0,4	●	-	●
CNGA120408FST	12,70	12,90	0,8	●	-	●

注: 刀杆和刀镗杆, 请见 B58-B73.



P			
M			
K			
N	●	○	●
S	●	●	●
H			

- 首选
- 备选

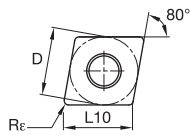
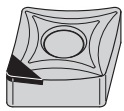

### ■ CNMS-E

目录编号	D	L10	Rε	KD1400	KD1405	KD1425
CNMS120408E	12,70	12,90	0,8	-	●	-

注: 刀杆和刀镗杆, 请见 B58-B73.

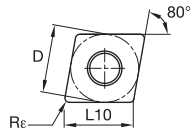
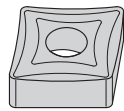

### ■ CNMS-FST

目录编号	D	L10	Rε	KD1400	KD1405	KD1425
CNMS120404FST	12,70	12,90	0,4	●	-	-
CNMS120408FST	12,70	12,90	0,8	●	-	●

注: 刀杆和刀镗杆, 请见 B58-B73.

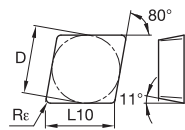
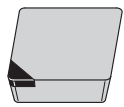

### ■ CPGN

目录编号	D	L10	Rε	KD1400	KD1405	KD1425
CPGN120304F	12,70	12,90	0,4	-	-	●
CPGN120308F	12,70	12,90	0,8	-	-	●

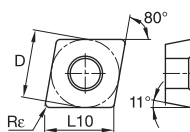
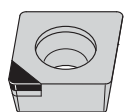

### ■ CPGW-E-F

目录编号	D	L10	Rε	KD1400	KD1405	KD1425
CPGW060204E	6,35	6,45	0,4	-	●	-
CPGW09T304E	9,53	9,67	0,4	-	●	-

注: 刀杆和刀镗杆, 请见 B192-B205.

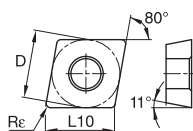

● 首选  
○ 备选

P			
M			
K			
N	●	○	●
S	●	●	●
H			

■ CPGW-FWST

目录编号	D	L10	Rε	KD1400	KD1405	KD1425
CPGW060204FWST	6,35	6,45	0,4	●	-	●
CPGW09T308FWST	9,53	9,67	0,8	●	-	●
CPGW120408FWST	12,70	12,90	0,8	●	-	●

注：刀杆和刀镗杆，请见 B192-B205.

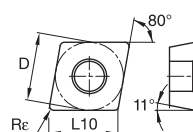

■ CPGW-ST

目录编号	D	L10	Rε	KD1400	KD1405	KD1425
CPGW060202FST	6,35	6,45	0,2	●	-	●
CPGW060204FST	6,35	6,45	0,4	●	-	●
CPGW060208FST	6,35	6,45	0,8	●	-	●
CPGW09T304FST	9,53	9,67	0,4	●	-	●
CPGW09T308FST	9,53	9,67	0,8	●	-	●

注：刀杆和刀镗杆，请见 B192-B205.

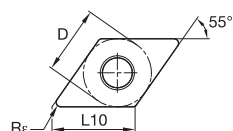
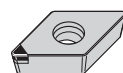

■ DCGW-ST

目录编号	D	L10	Rε	KD1400	KD1405	KD1425
DCGW070204FST	6,35	7,75	0,4	●	-	●
DCGW11T304FST	9,53	11,63	0,4	●	-	●

注：刀杆和刀镗杆，请见 B209-B213.

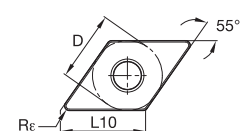
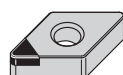

■ DNGA

目录编号	D	L10	Rε	KD1400	KD1405	KD1425
DNGA150404E	12,70	15,50	0,4	-	●	-

注：刀杆和刀镗杆，请见 B85-B93.

P	■	■	■
M	■	■	■
K	■	■	■
N	●	○	●
S	■	■	■
H	■	■	■

● 首选  
○ 备选

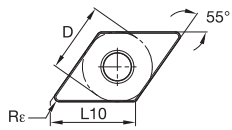
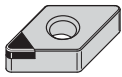

### ■ DNGA-FST

目录编号	D	L10	Rε	KD1400	KD1405	KD1425
DNGA150404FST	12,70	15,50	0,4	●	-	●
DNGA150408FST	12,70	15,50	0,8	●	-	●

注: 刀杆和刀镗杆, 请见 B192-B205.

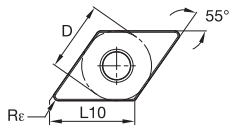
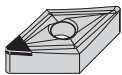

### ■ DNMS-FST

目录编号	D	L10	Rε	KD1400	KD1405	KD1425
DNMS150404FST	12,70	15,50	0,4	●	-	-
DNMS150408FST	12,70	15,50	0,8	●	-	●

注: 刀杆和刀镗杆, 请见 B192-B205.

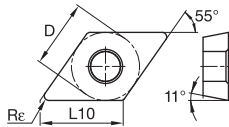
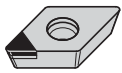

### ■ DPGW-E

目录编号	D	L10	Rε	KD1400	KD1405	KD1425
DPGW11T304E	9,53	11,63	0,4	-	●	-

注: 刀杆和刀镗杆, 请见 B217-B221.

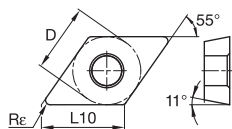
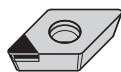

● 首选  
○ 备选

P			
M			
K			
N	●	○	●
S		●	●
H			

### ■ DPGW-FST

目录编号	D	L10	Rε	KD1400	KD1405	KD1425
DPGW070202FST	6,35	7,75	0,2	●	-	●
DPGW070204FST	6,35	7,75	0,4	●	●	●
DPGW11T304FST	9,53	11,63	0,4	●	-	●

注: 刀杆和刀镗杆, 请见 B217-B221.

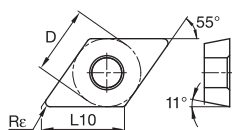

### ■ DPGW-FWST

目录编号	D	L10	Rε	KD1400	KD1405	KD1425
DPGW11T304FWST	9,53	11,63	0,2	-	-	●

注: 刀杆和刀镗杆, 请见 B217-B221.

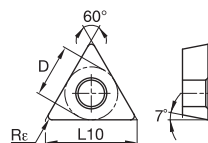
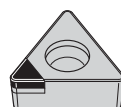

### ■ TCGW-FST

目录编号	D	L10	Rε	KD1400	KD1405	KD1425
TCGW110204FST	6,35	11,00	0,4	●	-	●
TCGW16T304FST	9,53	16,50	0,4	●	-	-

注: 刀杆和刀镗杆, 请见 B247-B248.

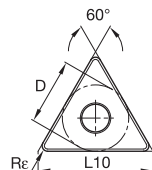
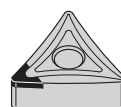

### ■ TNMS-FST

目录编号	D	L10	Rε	KD1400	KD1405	KD1425
TNMS160404FST	9,53	16,50	0,4	●	-	●
TNMS160408FST	9,53	16,50	0,8	●	-	●

注: 刀杆和刀镗杆, 请见 B132-B142.

P			
M			
K			
N	●	○	●
S		●	●
H			

● 首选  
○ 备选

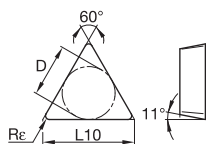
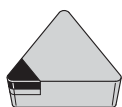

### TPGN

目录编号	D	L10	Rε	KD1400	KD1405	KD1425
TPGN110304F	6,35	11,00	0,4	-	-	●
TPGN160304F	9,53	16,50	0,4	-	-	●
TPGN160308F	9,53	16,50	0,8	-	-	●
TPGN220408F	12,70	22,00	0,8	-	-	●

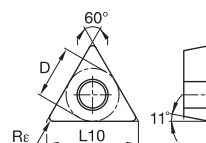

### TPGW-FST

目录编号	D	L10	Rε	KD1400	KD1405	KD1425
TPGW110204FST	6,35	11,00	0,4	●	-	●
TPGW110208FST	6,35	11,00	0,8	●	-	-
TPGW16T304FST	9,53	16,50	0,4	-	-	●
TPGW16T308FST	9,53	16,50	0,8	●	-	●

注: 刀杆和刀镗杆, 请见 B257-B263.

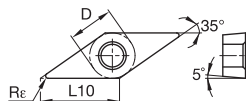
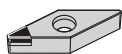

### VBGW-E

目录编号	D	L10	Rε	KD1400	KD1405	KD1425
VBGW160408E	9,53	16,61	0,8	-	●	-

注: 刀杆和刀镗杆, 请见 B266-B269.

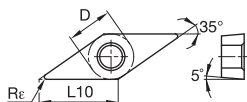
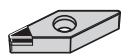

● 首选  
○ 备选

P	■	■	■
M	■	■	■
K	■	■	■
N	●	○	○
S	■	■	■
H	■	■	■

■ VBGW-FST

目录编号	D	L10	Rε	KD1400	KD1405	KD1425
VBGW110304FST	6,35	11,07	0,4	●	-	●
VBGW160404FST	9,53	16,61	0,4	●	-	●

注: 刀杆和刀镗杆, 请见 B266-B269.

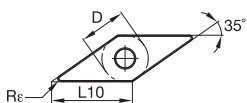
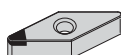

■ VNGA-FST

目录编号	D	L10	Rε	KD1400	KD1405	KD1425
VNGA160404FST	9,53	16,61	0,4	●	-	-
VNGA160408FST	9,53	16,61	0,8	●	-	●

注: 刀杆和刀镗杆, 请见 B149-B153.

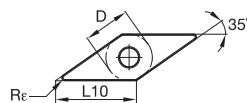
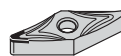

■ VNMS-E

目录编号	D	L10	Rε	KD1400	KD1405	KD1425
VNMS160404E	9,53	16,61	0,4	-	●	-
VNMS160408E	9,53	16,61	0,8	-	●	-

注: 刀杆和刀镗杆, 请见 B149-B153.

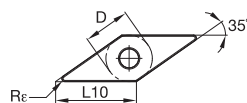
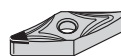

■ VNMS-FST

目录编号	D	L10	Rε	KD1400	KD1405	KD1425
VNMS160404FST	9,53	16,61	0,4	●	-	●
VNMS160408FST	9,53	16,61	0,8	●	-	●

注: 刀杆和刀镗杆, 请见 B149-B153.

P	■	■	■
M	■	■	■
K	■	■	■
N	●	○	○
S	■	■	■
H	■	■	■

● 首选  
○ 备选

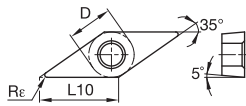
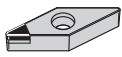

### ■ VPGN

目录编号	D	L10	Rε	KD1400	KD1405	KD1425
VCGN160404	9,53	16,61	0,4	-	-	●
VCGN160408	9,53	16,61	0,8	-	-	●

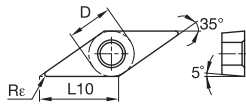
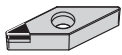

### ■ VPGR

目录编号	D	L10	Rε	KD1400	KD1405	KD1425
VCGR160404	9,53	16,61	0,4	-	-	●
VCGR160408	9,52	16,61	0,8	-	-	●
VCGR160412	9,53	16,61	1,2	-	-	●

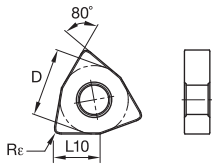
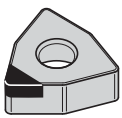

### ■ WNGA-FST

目录编号	D	L10	Rε	KD1400	KD1405	KD1425
WNGA080408FST	12,70	8,69	0,8	-	-	●

注: 刀杆和刀镗杆, 请见 B161-B165.

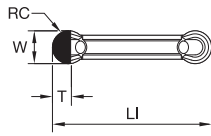
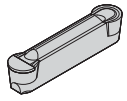

● 首选  
○ 备选

■ 平板圆角精磨 • PCD

目录编号	刀片尺寸	W	RC	LI	T
A4R0500M05P00E	5	5,00	2,5	25	3,0

注: A4刀杆, 镗刀杆, 刀板请见 C104-C135.

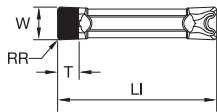
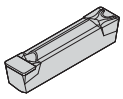

■ 精密研磨平板型 • PCD

目录编号	刀片尺寸	W	RR	LI	T
A4G0300M03P04E	3	3,00	0,4	20	3,0
A4G0400M04P04E	4	4,00	0,4	20	3,0
A4G0500M05P08E	5	5,00	0,8	25	3,0

注: A4刀杆, 镗刀杆, 刀板请见 C104-C135.

P	M	K	N	S	H	KCU10	KCU25	KCP10	KCP25	KCK20	K313	KC5010	KC5025	KY3500	KT315	KB1630	KB5625	KD1405	
●	●	●	○	○	○	-	-	-	-	-	-	-	-	-	-	-	-	-	●
○	○	○	○	○	○	-	-	-	-	-	-	-	-	-	-	-	-	-	○
○	○	○	○	○	○	-	-	-	-	-	-	-	-	-	-	-	-	-	○
○	○	○	○	○	○	-	-	-	-	-	-	-	-	-	-	-	-	-	○
○	○	○	○	○	○	-	-	-	-	-	-	-	-	-	-	-	-	-	○
○	○	○	○	○	○	-	-	-	-	-	-	-	-	-	-	-	-	-	○
○	○	○	○	○	○	-	-	-	-	-	-	-	-	-	-	-	-	-	○
○	○	○	○	○	○	-	-	-	-	-	-	-	-	-	-	-	-	-	○
○	○	○	○	○	○	-	-	-	-	-	-	-	-	-	-	-	-	-	○
○	○	○	○	○	○	-	-	-	-	-	-	-	-	-	-	-	-	-	○



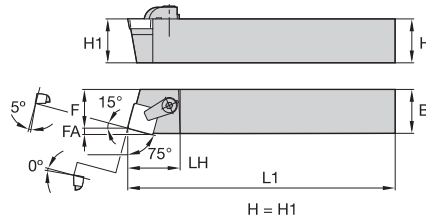
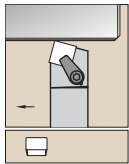

**CSBP 75°**

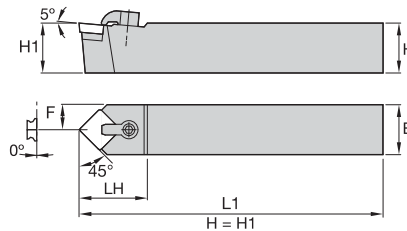
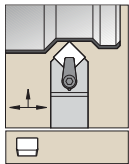
订货号	目录编号	H	B	F	L1	LH	FA	刀片	垫片	垫片螺钉	六角	夹具	夹紧螺钉	六角
右手														
1097750	CSBPR2020K12	20	20	17,0	125	30,0	3,1	SP..120308	SM840	MS111	2 mm	CKM10	STCM8	4 mm

**CSDP 45°**

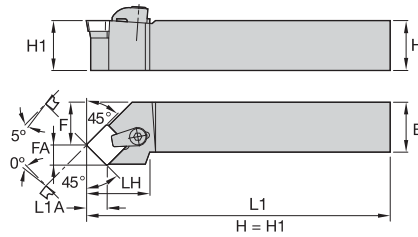
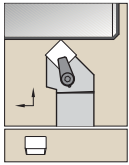

订货号	目录编号	H	B	F	L1	LH	刀片	垫片	垫片螺钉	六角	夹具	夹紧螺钉	六角
1097754	CSDPN2020K12	20	20	10,0	125	32,0	SP..120308	SM840	MS111	2 mm	CKM10	STCM8	4 mm
1097755	CSDPN2525M12	25	25	12,5	150	32,0	SP..120308	SM840	MS111	2 mm	CKM9	STCM4	4 mm



■ CSSP 45°

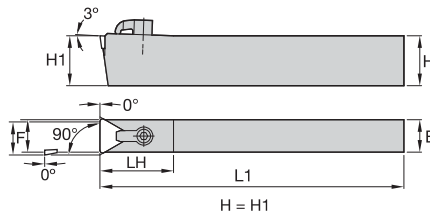
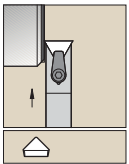

订货号	目录编号	H	B	F	L1	LH	FA	L1A	刀片	垫片	垫片螺钉	六角	夹具	夹紧螺钉	六角
右手															
1244605	CSSPR2020K12	20	20	25,0	125	32,0	8,7	8,3	SP..120308	SM840	MS111	2 mm	CKM10	STCM8	4 mm
1244606	CSSPR2525M12	25	25	32,0	150	32,0	8,7	8,3	SP..120308	SM840	MS111	2 mm	CKM9	STCM4	4 mm
左手															
1244604	CSSPL2525M12	25	25	32,0	150	32,0	8,7	8,3	SP..120308	SM840	MS111	2 mm	CKM9	STCM4	4 mm



■ CTCN 90°



订货号	目录编号	H	B	F	L1	LH	刀片	垫片	垫片螺钉	六角	夹具	夹紧螺钉	六角
1097775	CTCPN2510M11	25	10	10,0	150	26,0	TP..110304	SM819	MS960	—	CKM7	STCM5	2.5 mm
1097776	CTCPN2514M16	25	14	14,4	150	28,0	TP..160308	SM841	MS111	2 mm	CKM13	STCM4	4 mm
1097781	CTCPN2518M22	25	18	19,2	150	41,0	TP..220408	SM837	MS125	2.5 mm	CKM13	STCM4	4 mm
1097778	CTCPN2520M22	25	20	20,2	150	41,0	TP..220408	SM837	MS125	2.5 mm	CKM13	STCM4	4 mm

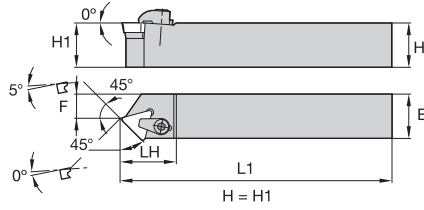
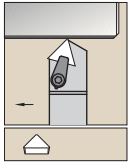
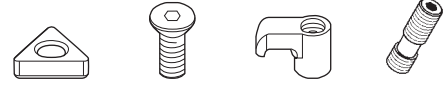

**CTDP 45°**

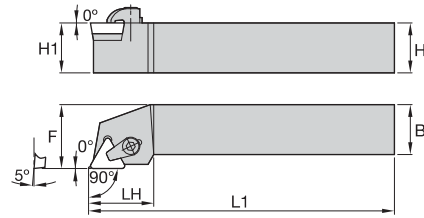
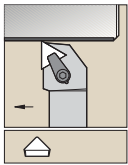
订货号	目录编号	H	B	F	L1	LH	刀片	垫片	垫片螺钉	夹具	夹紧螺钉	六角
右手												
1244613	CTDPR1212F11	12	12	6,0	80	22,0	TP..110304	SM819	MS960	CKM19	STCM9	2.5 mm

**CTGP 90°**

订货号	目录编号	H	B	F	L1	LH	刀片	垫片	垫片螺钉	六角	夹具	夹紧螺钉	六角
右手													
1097762	CTGPR1212F11	12	12	16,0	80	20,0	TP..110304	SM819	MS960	—	CKM19	STCM9	2.5 mm
1097763	CTGPR1616H11	16	16	20,0	100	20,0	TP..110304	SM819	MS960	—	CKM19	STCM9	2.5 mm
1244595	CTGPR2020K11	20	20	25,0	125	20,0	TP..110304	SM819	MS960	—	CKM19	STCM9	2.5 mm
1097764	CTGPR2020K16	20	20	25,0	125	26,0	TP..160308	SM841	MS111	2 mm	CKM10	STCM8	4 mm
1097765	CTGPR2525M16	25	25	32,0	150	26,0	TP..160308	SM841	MS111	2 mm	CKM9	STCM4	4 mm
左手													
1097916	CTGPL1212F11	12	12	16,0	80	20,0	TP..110304	SM819	MS960	—	CKM19	STCM9	2.5 mm
1097918	CTGPL2020K16	20	20	25,0	125	26,0	TP..160308	SM841	MS111	2 mm	CKM10	STCM8	4 mm
1097919	CTGPL2525M16	25	25	32,0	150	26,0	TP..160308	SM841	MS111	2 mm	CKM9	STCM4	4 mm

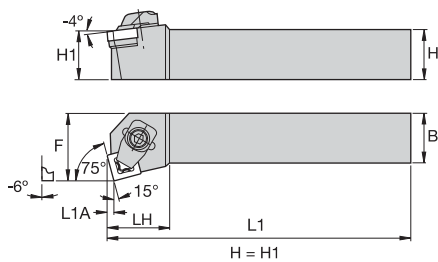
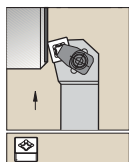
ISO 车削刀具



## ■ CCKN 75° • MX

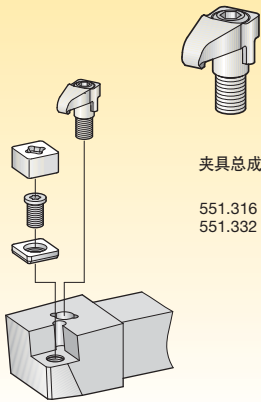
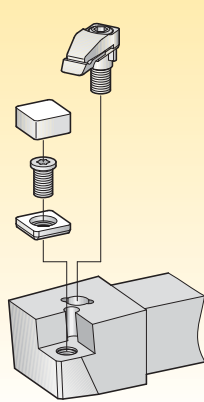

订货号	目录编号	H	B	F	L1	LH	L1A	刀片	垫片	垫片螺钉	六角	夹具装配件	六角
右手													
2891706	CCKNR2525M12MX7	25	25	32,0	150	32,0	3,1	CNGX120708	552.221	554.252	2.5 mm	551.013	4 mm
左手													
2891727	CCKNL2525M12MX7	25	25	32,0	150	32,0	3,1	CNGX120708	552.221	554.252	2.5 mm	551.013	4 mm

**■ 配件 • -MX, -MN, -MF, 和 -MA 刀片夹持形式图解**
**夹具类型**
**MX**

**夹具类型**
**MN**

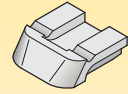
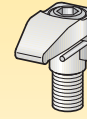
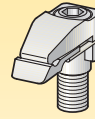
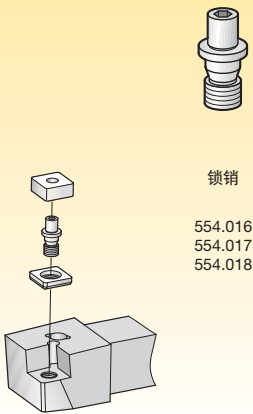
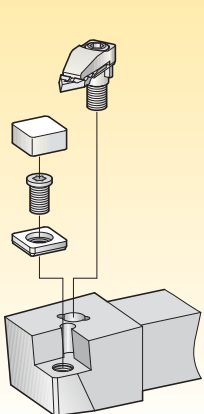
## 单个夹具零件

**夹具类型**
**MA**

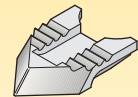
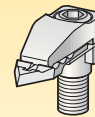
**夹具类型**
**MF**

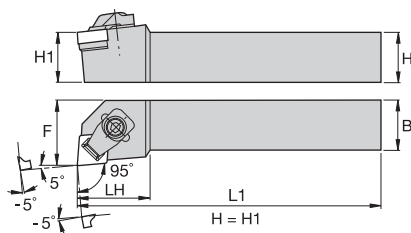
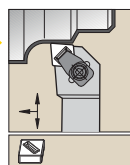
## 单个夹具零件





■ CCLN 95° • MX



订货号	目录编号	H	B	F	L1	LH	刀片	垫片	垫片螺钉	六角	夹具装配件	六角
右手												
1260025	CCLNR2525M12-MX7	25	25	32,0	150	32,0	CN.X120708	552.221	554.252	2.5 mm	551.316	4 mm
1260028	CCLNR3225P12-MX7	32	25	32,0	170	32,0	CN.X120708	552.221	554.252	2.5 mm	551.316	4 mm
左手												
1260017	CCLNL2525M12-MX7	25	25	32,0	150	30,0	CN.X120708	552.221	554.252	2.5 mm	551.316	4 mm
1260020	CCLNL3225P12-MX7	32	25	32,0	170	32,0	CN.X120708	552.221	554.252	2.5 mm	551.316	4 mm

■ CCLN 95° • MN



订货号	目录编号	H	B	F	L1	LH	刀片	垫片	垫片螺钉	六角	断屑器	夹具装配件	六角
右手													
1260023	CCLNR2525M12-MN4	25	25	32,0	150	32,0	CN.N120408	552.220	554.252	2.5 mm	557.111	551.317	4 mm
1260024	CCLNR2525M12-MN7	25	25	32,0	150	32,0	CN.N120708	552.221	554.252	2.5 mm	557.111	551.317	4 mm
1504937	CCLNR3225P12-MN4	32	25	32,0	170	32,0	CN.N120408	552.220	554.252	2.5 mm	557.111	551.317	4 mm
1260027	CCLNR3225P12-MN7	32	25	32,0	170	32,0	CN.N120708	552.221	554.252	2.5 mm	557.111	551.317	4 mm
左手													
1260015	CCLNL2525M12-MN4	25	25	32,0	150	32,0	CN.N120408	552.220	554.252	2.5 mm	557.111	551.317	4 mm
1260016	CCLNL2525M12-MN7	25	25	32,0	150	32,0	CN.N120708	552.221	554.252	2.5 mm	557.111	551.317	4 mm
1504931	CCLNL3225P12-MN7	32	25	32,0	170	32,0	CN.N120708	552.221	554.252	2.5 mm	557.111	551.317	4 mm

■ CCLN 95° • MF



订货号	目录编号	H	B	F	L1	LH	刀片	垫片	垫片螺钉	六角	断屑器	夹具装配件	六角
右手													
1260022	CCLNR2525M12-MF4	25	25	32,0	150	32,0	CN.N120408	552.220	554.252	2.5 mm	557.125	551.317	4 mm
1503826	CCLNR2525M12-MF7	25	25	32,0	150	32,0	CN.N120708	552.221	554.252	2.5 mm	557.125	551.317	4 mm
左手													
1260014	CCLNL2525M12-MF4	25	25	32,0	150	32,0	CN.N120408	552.220	554.252	2.5 mm	557.125	551.317	4 mm
1504935	CCLNL2525M12-MF7	25	25	32,0	150	32,0	CN.N120708	552.221	554.252	2.5 mm	557.125	551.317	4 mm

注: 图中所示为 MX - 夹持装置。  
 可以单独订购基本刀柄产品:  
 V.CLN R/L 2525M12  
 V.CLN R/L 3225P12  
 V.CLN R/L 3225P16

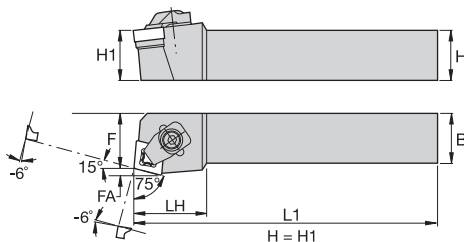
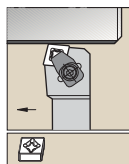
**■ CCRN 75° • MN**

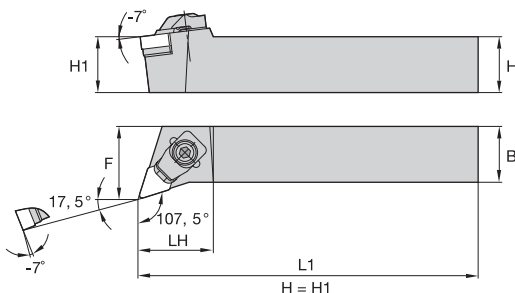
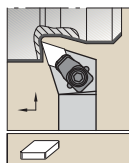

订货号	目录编号	H	B	F	L1	LH	FA	刀片	垫片	垫片螺钉	六角	断屑器	夹具装配件	六角	
<b>右手</b>															
1504885	CCRN3225P12-MN7	32	25	27,0	170	35,0	3,1	CN.N120708	552.221	554.252	2.5 mm	557.111	551.317	4 mm	
<b>左手</b>															
1503827	CCRN2525M12-MN7	25	25	27,0	150	35,0	3,1	CN.N120708	552.221	554.252	2.5 mm	557.111	551.317	4 mm	

注: MX - 夹具类型已经注明。  
 可以单独订购基本刀柄产品:  
 V.CRN R/L 2525M12  
 V.CRN R/L 3225P12  
 V.CRN R/L 3225P16

**■ CDHN 107,5° • MX**

订货号	目录编号	H	B	F	L1	LH	刀片	垫片	垫片螺钉	六角	夹具装配件	六角
<b>右手</b>												
1505504	CDHNR2525M12-MX7	25	25	32,0	150	30,0	DN.X120708	552.225	554.254	2.5 mm	551.316	4 mm

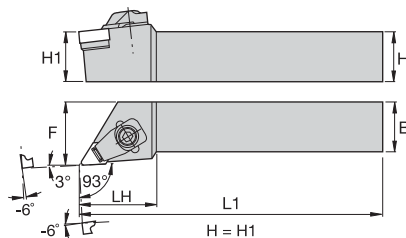
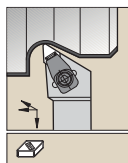
注: 图中所示为 MN - 型夹持装置。  
 可以单独订购基本刀柄产品:  
 V.DHN R/L 2525M12  
 V.DHN R/L 2525M15  
 V.DHN R/L 3225P15



## ■ CDJN 93° • MX



订货号	目录编号	H	B	F	L1	LH	刀片	垫片	垫片螺钉	六角	夹具及配件	六角
右手												
1260177	CDJNR2525M15-MX7	25	25	32,0	150	38,0	DN.X150708	552.228	554.252	2.5 mm	551.332	4 mm
左手												
1260172	CDJNL2525M12-MX7	25	25	32,0	150	38,0	DN.X120708	552.225	554.254	2.5 mm	551.316	4 mm
1504968	CDJNL2525M15MX7	25	25	32,0	150	38,0	DN.X150708	552.228	554.252	2.5 mm	551.332	4 mm

## ■ CDJN 93° • MN



订货号	目录编号	H	B	F	L1	LH	刀片	垫片	垫片螺钉	六角	断屑器	夹具及配件	六角
右手													
1260176	CDJNR2525M15MN7	25	25	32,0	150	38,0	DN.N150708	552.228	554.252	2.5 mm	557.111	551.317	4 mm
1327362	CDJNR3225P15MN7	32	25	32,0	170	38,0	DN.N150708	552.228	554.252	2.5 mm	557.111	551.317	4 mm
左手													
1504969	CDJNL2525M15MN7	25	25	32,0	150	38,0	DN.N150708	552.228	554.252	2.5 mm	557.111	551.317	4 mm
1327363	CDJNL3225P15MN7	32	25	32,0	170	38,0	DN.N150708	552.228	554.252	2.5 mm	557.111	551.317	4 mm



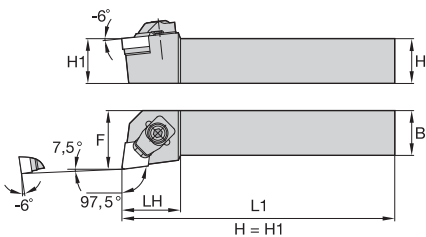
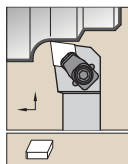

■ CELN 97,5° • MX

订货号	目录编号	H	B	F	L1	LH	刀片	垫片	垫片螺钉	六角	夹具装配件	六角
右手												
1505803	CELNR2525M13-MX7	25	25	32,0	150	32,0	EN.X130708	552.240	554.252	2.5 mm	551.316	4 mm

■ CELN 97,5° • MN

订货号	目录编号	H	B	F	L1	LH	刀片	垫片	垫片螺钉	六角	断屑器	夹具装配件	六角
右手													
1501222	CELNR2525M13MN7	25	25	32,0	150	32,0	EN.N130708	552.240	554.252	2.5 mm	557.111	551.317	4 mm
左手													
1501221	CELNL2525M13MN7	25	25	32,0	150	32,0	EN.N130708	552.240	554.252	2.5 mm	557.111	551.317	4 mm

■ CELN 97,5° • MF

订货号	目录编号	H	B	F	L1	LH	刀片	垫片	垫片螺钉	六角	断屑器	夹具装配件	六角
右手													
1331458	CELNR2525M13MF7	25	25	32,0	150	32,0	EN.N130708	552.240	554.252	2.5 mm	557.125	551.317	4 mm

注: 图中所示为 MN - 型夹持装置。  
可以单独订购基本刀柄产品:  
V.ELN R/L 2525M13  
V.ELN R/L 3225P13

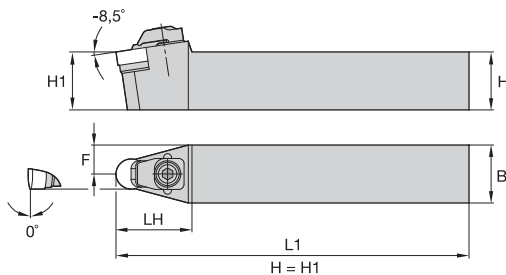
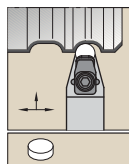

■ CRDN • MN



订货号	目录编号	H	B	F	L1	LH	刀片	垫片	垫片螺钉	六角	断屑器	夹具装配件	六角
1510281	CRDNN2525M12MN4	25	25	12,5	150	30,0	RN.N120400	552.229	554.252	2.5 mm	557.111	551.333	4 mm
1313053	CRDNN2525M12MN7	25	25	12,5	150	30,0	RN.N120700	552.230	554.252	2.5 mm	557.111	551.333	4 mm
1502204	CRDNN3225P12MN4	32	25	12,5	170	30,0	RN.N120400	552.229	554.252	2.5 mm	557.111	551.333	4 mm
1320407	CRDNN3225P12MN7	32	25	12,5	170	30,0	RN.N120700	552.230	554.252	2.5 mm	557.111	551.333	4 mm

注: 图中所示为 MN - 型夹持装置。  
可以单独订购基本刀柄产品:  
V.RDN N 2525M12  
V.RDN N 3225M12

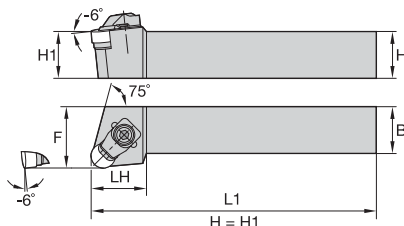
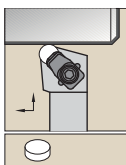

■ CRSN • MN



订货号	目录编号	H	B	F	L1	LH	刀片	垫片	垫片螺钉	六角	断屑器	夹具装配件	六角
右手													
1510285	CRSNR2525M12-MN4	25	25	32,0	150	26,0	RN.N120400	552.229	554.252	2.5 mm	557.111	551.333	4 mm
1324116	CRSNR2525M12MN7	25	25	32,0	150	26,0	RN.N120700	552.230	554.252	2.5 mm	557.111	551.333	4 mm
1510286	CRSNR3225P12MN4	32	25	32,0	170	26,0	RN.N120400	552.229	554.252	2.5 mm	557.111	551.333	4 mm
1261273	CRSNR3225P12MN7	32	25	32,0	170	26,0	RN.N120700	552.230	554.252	2.5 mm	557.111	551.333	4 mm
左手													
1510282	CRSNL2525M12-MN4	25	25	32,0	150	26,0	RN.N120400	552.229	554.252	2.5 mm	557.111	551.333	4 mm
1510283	CRSNL2525M12MN7	25	25	32,0	150	26,0	RN.N120700	552.230	554.252	2.5 mm	557.111	551.333	4 mm
1510284	CRSNL3225P12MN4	32	25	32,0	170	26,0	RN.N120400	552.229	554.252	2.5 mm	557.111	551.333	4 mm
1331597	CRSNL3225P12MN7	32	25	32,0	170	26,0	RN.N120700	552.230	554.252	2.5 mm	557.111	551.333	4 mm

注: 图中所示为 MN - 型夹持装置。  
可以单独订购基本刀柄产品:  
V.RSN R/L 2525M12  
V.RSN R/L 3225P12

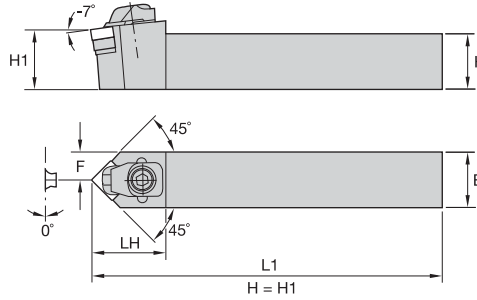
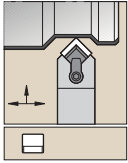

**■ CSDN • MX**

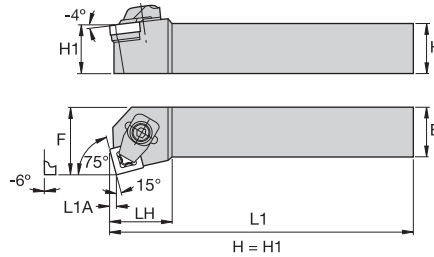
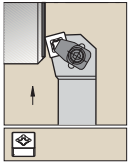
订货号	目录编号	H	B	F	L1	LH	刀片	垫片	垫片螺钉	六角	夹具装配件	六角
2891696	CSDNN2525M12MX7	25	25	12,5	151	36,0	SNGX120708	552.232	554.252	2.5 mm	551.316	4 mm

**■ CSKN 75° • MN**

订货号	目录编号	H	B	F	L1	LH	L1A	刀片	垫片	垫片螺钉	六角	断屑器	夹具装配件	六角
<b>右手</b>														
1261315	CSKNR2525M12-MN7	25	25	32,0	150	27,0	3,0	SN.N120708	552.232	554.252	2.5 mm	557.111	551.317	4 mm
<b>左手</b>														
1261299	CSKNL2525M12-MN4	25	25	32,0	150	27,0	3,0	SN.N120408	552.231	554.252	2.5 mm	557.111	551.317	4 mm
1261300	CSKNL2525M12-MN7	25	25	32,0	150	27,0	3,0	SN.N120708	552.232	554.252	2.5 mm	557.111	551.317	4 mm

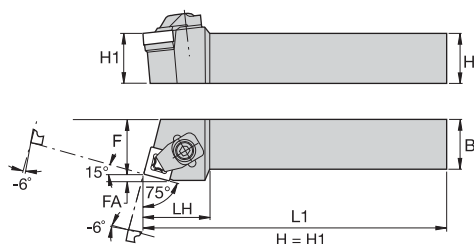
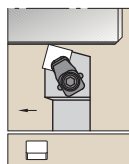
注: 图中所示为 MX - 夹持装置。  
可以单独订购基本刀柄产品:  
V.SKN R/L 2525M12



## ■ CSRN 75° • MX



订货号	目录编号	H	B	F	L1	LH	FA	刀片	垫片	垫片螺钉	六角	夹具装配件	六角
左手													
1510300	CSRNL3225P15-MX7	32	25	27,0	170	34,0	4,1	SN.X150708	552.234	554.253	3 mm	551.316	4 mm

注: 图中所示为 MX - 夹持装置。  
可以单独订购基本刀柄产品:  
V.SRN R/L 2525M12  
V.SRN R/L 3225P12  
V.SRN R/L 3225P15

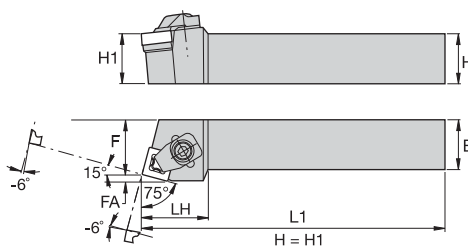
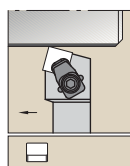

## ■ CSRN 75° • MN



订货号	目录编号	H	B	F	L1	LH	FA	刀片	垫片	垫片螺钉	六角	断屑器	夹具装配件	六角
右手														
1510303	CSRNR2525M12-MN4	25	25	27,0	150	32,0	3,1	SN.N120408	552.231	554.252	2.5 mm	557.111	551.317	4 mm
1261336	CSRNR2525M12-MN7	25	25	27,0	150	32,0	3,1	SN.N120708	552.232	554.252	2.5 mm	557.111	551.317	4 mm
左手														
1510291	CSRNL2525M12-MN4	25	25	27,0	150	32,0	3,1	SN.N120408	552.231	554.252	2.5 mm	557.111	551.317	4 mm
1510292	CSRNL2525M12-MN7	25	25	27,0	150	32,0	3,1	SN.N120708	552.232	554.252	2.5 mm	557.111	551.317	4 mm
1261334	CSRNL3225P12-MN7	32	25	27,0	170	32,0	3,1	SN.N120708	552.232	554.252	2.5 mm	557.111	551.317	4 mm

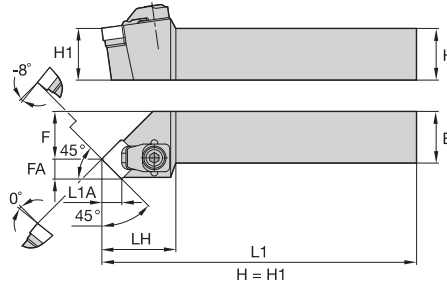
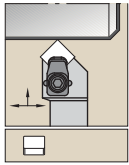

■ CSSN 45° • MX



订货号	目录编号	H	B	F	L1	LH	FA	L1A	刀片	垫片	垫片螺钉	六角	夹具装配件	六角
右手														
1261367	CSSNR2525M12-MX7	25	25	32,0	150	35,0	8,3	8,3	SN.X120708	552.232	554.252	2.5 mm	551.316	4 mm
1261378	CSSNR3225P15-MX7	32	25	32,0	159	37,0	10,6	10,6	SN.X150708	552.234	554.253	3 mm	551.316	4 mm
左手														
1261350	CSSNL2525M12-MX7	25	25	23,7	150	35,0	8,6	8,3	SN.X120708	552.232	554.252	2.5 mm	551.316	4 mm

■ CSSN 45° • MN



订货号	目录编号	H	B	F	L1	LH	FA	L1A	刀片	垫片	垫片螺钉	六角	断屑器	夹具装配件	六角
右手															
1261366	CSSNR2525M12-MN7	25	25	32,0	142	35,0	8,3	8,3	SN.N120708	552.232	554.252	2.5 mm	557.111	551.317	4 mm
1261370	CSSNR3225P12-MN4	32	25	32,0	162	35,0	8,3	8,3	SN.N120408	552.231	554.252	2.5 mm	557.111	551.317	4 mm
1261371	CSSNR3225P12-MN7	32	25	32,0	162	35,0	8,3	8,3	SN.N120708	552.232	554.252	2.5 mm	557.111	551.317	4 mm
左手															
1261349	CSSNL2525M12-MN7	25	25	32,0	142	35,0	8,3	8,3	SN.N120708	552.232	554.252	2.5 mm	557.111	551.317	4 mm
1261353	CSSNL3225P12-MN4	32	25	32,0	162	35,0	8,3	8,3	SN.N120408	552.231	554.252	2.5 mm	557.111	551.317	4 mm
1261354	CSSNL3225P12-MN7	32	25	32,0	162	35,0	8,3	8,3	SN.N120708	552.232	554.252	2.5 mm	557.111	551.317	4 mm

ISO 车削刀具

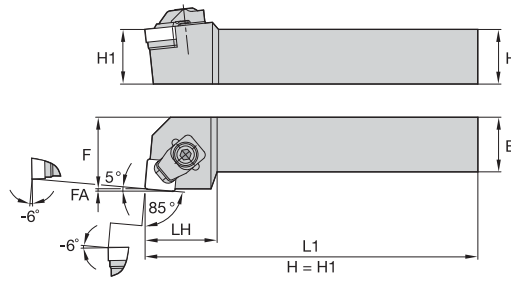
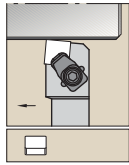

■ CSXN 85° • MX



订货号	目录编号	H	B	F	L1	LH	FA	刀片	垫片	垫片螺钉	六角	夹具装配件	六角
右手													
1510334	CSXNR3225P12-MX7	32	25	32,0	170	30,0	1,1	SN.X120708	552.232	554.252	2.5 mm	551.316	4 mm

■ CSXN 85° • MN



订货号	目录编号	H	B	F	L1	LH	FA	刀片	垫片	垫片螺钉	六角	断屑器	夹具装配件	六角
右手														
1510327	CSXNR2525M12-MN4	25	25	32,0	150	30,0	1,1	SN.N120408	552.231	554.252	2.5 mm	557.111	551.317	4 mm
左手														
1510313	CSXNL2525M12-MN4	25	25	32,0	150	30,0	1,1	SN.N120408	552.231	554.252	2.5 mm	557.111	551.317	4 mm

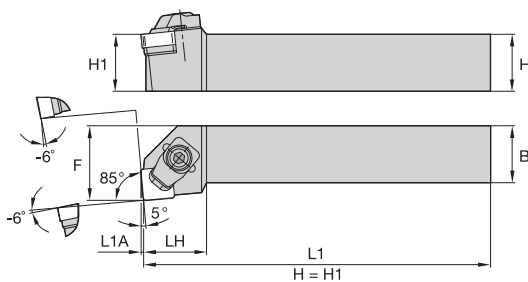
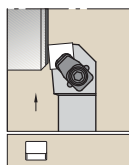

**CSYN 85° • MX**

订货号	目录编号	H	B	F	L1	LH	L1A	刀片	垫片	垫片螺钉	六角	夹具装配件	六角
左手													
1261414	CSYNL3225P12-MX7	32	25	32,0	170	27,0	1,0	SN.X120708	552.232	554.252	2.5 mm	551.316	4 mm

**CSYN 85° • MN**

订货号	目录编号	H	B	F	L1	LH	L1A	刀片	垫片	垫片螺钉	六角	断屑器	夹具装配件	六角
右手														
1261423	CSYNR2525M12-MN7	25	25	32,0	150	27,0	1,1	SN.N120708	552.232	554.252	2.5 mm	557.111	551.317	4 mm
左手														
1261408	CSYNL2525M12-MN7	25	25	32,0	150	27,0	1,1	SN.N120708	552.232	554.252	2.5 mm	557.111	551.317	4 mm

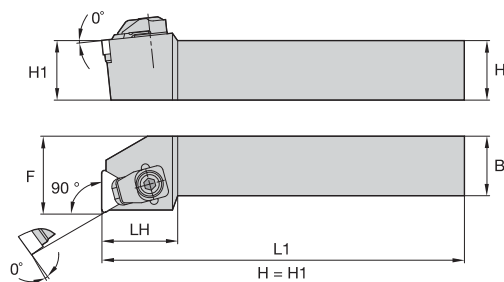
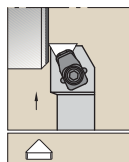
注: 图中所示为 MN - 型夹持装置。  
 可以单独订购基本刀柄产品:  
 V.SYN R/L 2525M12  
 V.SYN R/L 3225P12



■ CTFN 90° • MN



订货号	目录编号	H	B	F	L1	LH	刀片	垫片	垫片螺钉	六角	断屑器	夹具配件	六角
右手													
1510344	CTFN2525M16-MN4	25	25	32,0	150	29,0	TN.N160408	552.235-H	554.254	2.5 mm	557.111	551.333	4 mm
左手													
1510341	CTFN2525M16-MN4	25	25	32,0	150	29,0	TN.N160408	552.235-H	554.254	2.5 mm	557.111	551.333	4 mm

注: 图中所示为 MN - 型夹持装置。  
可以单独订购基本刀柄产品:  
V.TFN R/L 2525M16

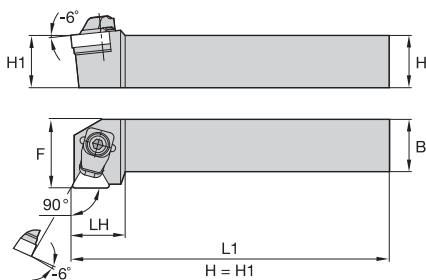
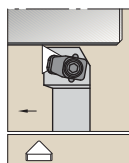

■ CTGN 90° • MN



订货号	目录编号	H	B	F	L1	LH	刀片	垫片	垫片螺钉	六角	断屑器	夹具配件	六角
右手													
1261482	CTGNR2525M16-MN4	25	25	32,0	150	20,0	TN.N160408	552.235-H	554.254	2.5 mm	557.111	551.333	4 mm
1261483	CTGNR2525M16-MN7	25	25	32,0	150	20,0	TN.N160708	552.236	554.254	2.5 mm	557.111	551.333	4 mm
左手													
1261478	CTGNL2525M16-MN4	25	25	32,0	150	20,0	TN.N160408	552.235-H	554.254	2.5 mm	557.111	551.333	4 mm
1261479	CTGNL2525M16-MN7	25	25	32,0	150	20,0	TN.N160708	552.236	554.254	2.5 mm	557.111	551.333	4 mm

注: 图中所示为 MN - 型夹持装置。  
可以单独订购基本刀柄产品:  
V.TGN R/L 2525M16



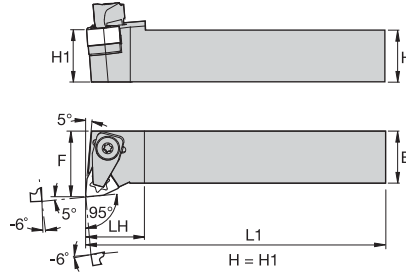
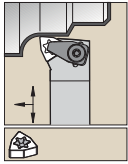

■ CWLN 95° • MX



订货号	目录编号	H	B	F	L1	LH	刀片	垫片	垫片螺钉	六角	夹具装配件	六角
右手												
1873227	CWLN R3225P08-MX7	32	25	32,0	170	32,0	WN.X080708	552.210	554.252	2.5 mm	551.316	4 mm
左手												
1873224	CWLN L2525M08-MX7	25	25	32,0	150	32,0	WN.X080708	552.210	554.252	2.5 mm	551.316	4 mm

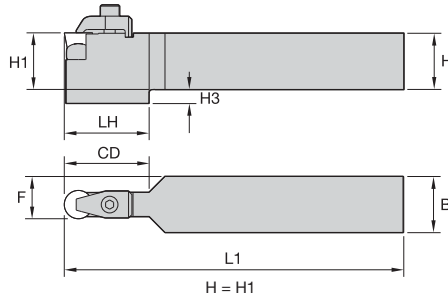
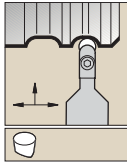

■ CRDP

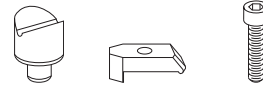

订货号	目录编号	H	B	F	L1	LH	H3	CD	刀片	套	夹具	夹紧螺钉	六角
3642247	CRDPN2525M06V	25	25	12,5	151	—	—	19,0	RPGX060400E	NST1	CM214	MS1321	2.5 mm
3642249	CRDPN3232P09V	32	32	16,0	171	—	—	29,0	RPGX090700E	NST2	CM219	CS412	3.5 mm
3642248	CRDPN2525M09V	25	25	12,5	151	—	—	29,0	RPGX090700E	NST2	CM219	CS412	3.5 mm
3642251	CRDPN3232P12V	32	32	16,0	171	—	—	38,0	RPGX120700E	NST3	CM216	CS412	3.5 mm
3642252	CRDPN3232P15V	32	32	16,0	171	38,1	6,4	38,0	RPGX151000	NST4	CM217	MS1294	6 mm

注: CRDP 刀柄可以使用 RPGX 和 RCGX 类型刀片。

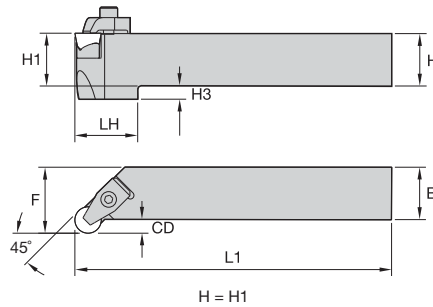
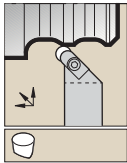

■ CRGP

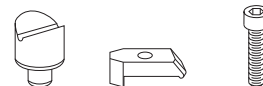

订货号	目录编号	H	B	F	L1	CD	刀片	套	夹具	夹紧螺钉	六角
右手											
3642276	CRGPR2525M06V	25	25	32,0	151	7,0	RPGX060400E	NST1	CM214	MS1321	2.5 mm
3642280	CRGPR3232P09V	32	32	40,0	171	8,0	RPGX090700E	NST2	CM219	CS412	3.5 mm
左手											
3642277	CRGPL2525M06V	25	25	32,0	151	7,0	RPGX060400E	NST1	CM214	MS1321	2.5 mm
3642281	CRGPL3232P09V	32	32	40,0	171	8,0	RPGX090700E	NST2	CM219	CS412	3.5 mm

注: CRGP 刀柄可以使用 RPGX 和 RCGX 类型刀片。

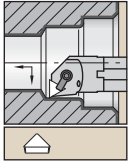

带内冷功能的钢质刀柄。

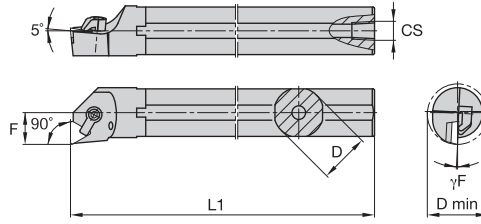
**■ A-CTFP 90°**

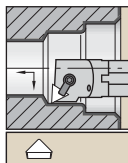

订货号	目录编号	D	D min	F	L1	CS	γF°	刀片	垫片	垫片螺钉	六角	夹具	夹紧螺钉	六角
<b>右手</b>														
1886492	A16RCTFPR11	16	20,0	11,0	200	1/8-27 NPT	-4.0	TP..110304	—	—	—	CKM19	STCM9	2.5 mm
1098051	A20QCTFPR11	20	25,0	13,0	180	1/8-27 NPT	0.0	TP..110304	SM815	MS961	—	CKM19	STCM9	2.5 mm
1098053	A25RCTFPR16	25	32,0	17,0	200	1/4-18 NPT	-3.0	TP..160308	SM841	MS110	2 mm	CKM10	STCM8	4 mm
1098055	A32SCTFPR16	32	40,0	22,0	250	1/4-18 NPT	-3.0	TP..160308	SM841	MS110	2 mm	CKM10	STCM8	4 mm
1886494	A40VCTFPR16	40	48,0	27,0	400	1/4-18 NPT	-3.0	TP..160308	SM841	MS110	2 mm	CKM10	STCM8	4 mm
<b>左手</b>														
1098054	A25RCTFPL16	25	32,0	17,0	200	1/4-18 NPT	-3.0	TP..160308	SM841	MS110	2 mm	CKM10	STCM8	4 mm
1098056	A32SCTFPL16	32	40,0	22,0	250	1/4-18 NPT	-3.0	TP..160308	SM841	MS110	2 mm	CKM10	STCM8	4 mm

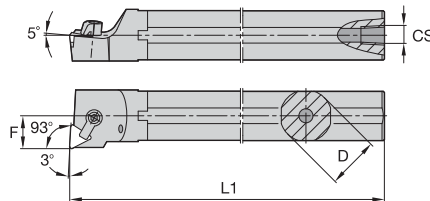
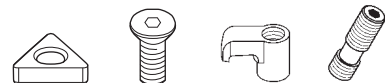

带内冷功能的钢质刀柄。

**■ A-CTUP 93°**

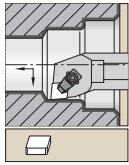
订货号	目录编号	D	D min	F	L1	CS	刀片	垫片	垫片螺钉	夹具	夹紧螺钉	六角
<b>右手</b>												
1098057	A16MCTUPR11	16	20,0	11,0	150	1/8-27 NPT	TP..110304	SM815	MS961	CKM19	STCM9	2.5 mm
<b>左手</b>												
1098058	A16MCTUPL11	16	20,0	11,0	150	1/8-27 NPT	TP..110304	SM815	MS961	CKM19	STCM9	2.5 mm



不带内冷的钢质刀杆。

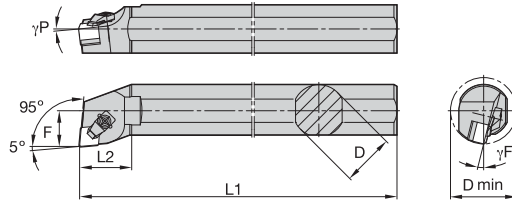

■ S-CCLN 95° • MX



订货号	目录编号	D	D min	F	L1	L2	γF°	γP°	刀片	垫片	垫片螺钉	六角	夹具装配件	六角
右手														
2890773	S32SCCLNR12MX7	32	40,0	22,0	251	43	-14.0	-5.0	CN.X120708	—	—	—	551.316	4 mm
1289077	S40T-CCLNR12-MX7	40	55,0	27,0	300	40	-14.0	-6.0	CN.X120708	552.221	554.252	2.5 mm	551.316	4 mm
左手														
1510401	S40T-CCLNL12-MX7	40	55,0	27,0	300	40	-14.0	-6.0	CN.X120708	552.221	554.252	2.5 mm	551.316	4 mm

注: 图中所示为 MN — 型夹持装置。  
可以单独订购基本刀柄产品:  
S40T-V.CLN R/L 12

■ S-CCLN 95° • MN



订货号	目录编号	D	D min	F	L1	L2	γF°	γP°	刀片	垫片	垫片螺钉	六角	断屑器	夹具装配件	六角
右手															
1289075	S40T-CCLNR12-MN4	40	55,0	27,0	300	40	-14.0	-6.0	CN.N120408	552.220	554.252	2.5 mm	557.111	551.317	4 mm
1289076	S40T-CCLNR12-MN7	40	55,0	27,0	300	40	-14.0	-6.0	CN.N120708	552.221	554.252	2.5 mm	557.111	551.317	4 mm
左手															
1289072	S40T-CCLNL12-MN7	40	55,0	27,0	300	40	-14.0	-6.0	CN.N120708	552.221	554.252	2.5 mm	557.111	551.317	4 mm

注: 图中所示为 MN — 型夹持装置。  
可以单独订购基本刀柄产品:  
S40T-V.SSN R/L 12

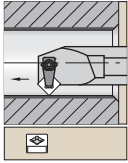

不带内冷的钢质刀杆。

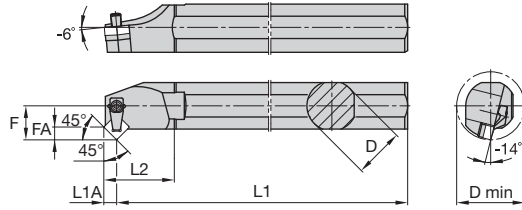

**■ S-CSSN 45° • MX**

订货号	目录编号	D	D min	F	L1	L2	L1A	FA	刀片	垫片	垫片螺钉	六角	夹具装配件	六角
<b>右手</b>														
1873498	S40T-CSSNR12-MX7	40	55,0	27,0	300	67,0	8,3	8,3	SN.X120708	552.232	554.252	2.5 mm	551.316	4 mm
<b>左手</b>														
1873499	S40T-CSSNL12-MX7	40	55,0	27,0	300	67,0	8,3	8,3	SN.X120708	552.232	554.252	2.5 mm	551.316	4 mm

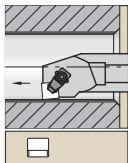
注: 图中所示为 MX 一 夹持装置。  
可以单独订购基本刀柄产品:  
S40T-V.SSN R/L 12

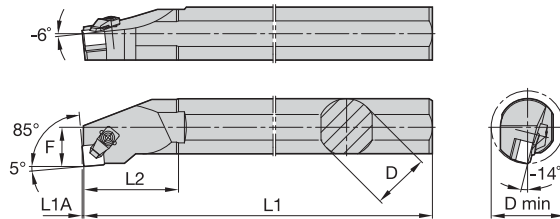

不带内冷的钢质刀杆。



**■ S-CSYN 85° • MN**

订货号	目录编号	D	D min	F	L1	L2	L1A	刀片	垫片	垫片螺钉	六角	断屑器	夹具装配件	六角
<b>右手</b>														
1245016	S40T-CSYNR12-MN7	40	55,0	27,0	300	67,0	1,0	SN.N120708	552.232	554.252	2.5 mm	557.111	551.317	4 mm

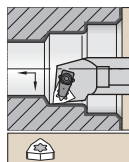
注: 图中所示为 MN 一 型夹持装置。  
可以单独订购基本刀柄产品:  
S40T-V.SYN R/L 08

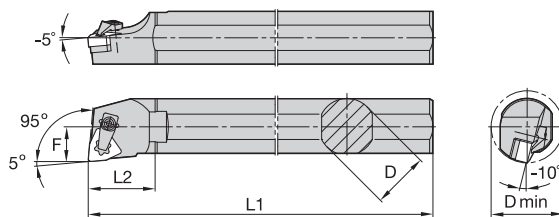

不带内冷的钢质刀杆。



■ S-CWLN 95° • MX



订货号	目录编号	D	D min	F	L1	L2	γF°	刀片	垫片	垫片螺钉	六角	夹具装配件	六角
左手													
1873496	S40T-CWLN08-MX7	40	80,0	27,0	300	55,0	-10.0 deg	WN.X080708	552.210	554.252	2.5 mm	551.316	4 mm

注: 可以单独订购基本刀柄产品:  
S40T-V. WLN R/L 12

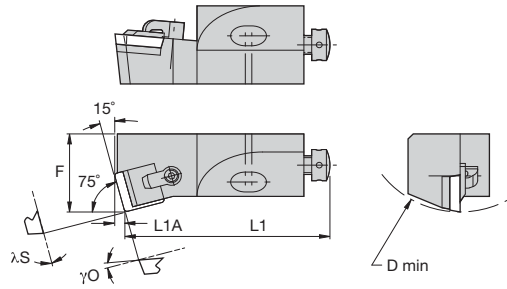

**■ CSKP 75°**

订货号	目录编号	D min	F	L1	L1A	λS°	γO°	刀片
右手 1261328	CSKPR12CA12	50	20,0	55	3,1	0.0	5.0	SP..120308/SP..422

**■ 配件**

D min	垫片	夹具	夹紧螺钉	六角	径向调节螺钉	六角	轴向调整螺钉	安装螺钉	六角	垫片
50	—	CKM34	STCM38	2 mm	KUAM22	2 mm	KUAM31	191.406	4 mm	CSWM 060 050

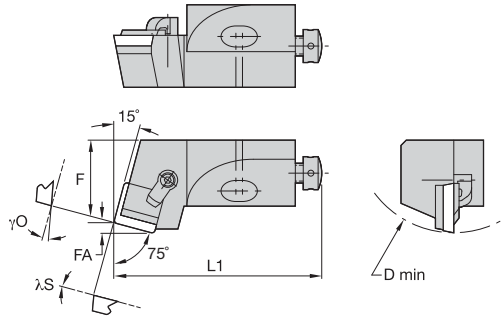
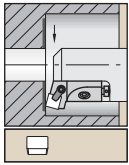
ISO 车削刀具



■ CSRPR 75°

订货号	目录编号	D min	F	L1	FA	λS°	γO°	刀片
右手 3331132	CSRPR10CA09	40	14,0	50	2,2	0.0	0.0	SP..090308/SP..322

■ 配件



D min	夹具	夹紧螺钉	六角	径向调节螺钉	六角	轴向调整螺钉	安装螺钉	六角	垫片
40	CKM34	STCM38	2 mm	KUAM28	2 mm	KUAM30	191.405	4 mm	CSWM 060 050



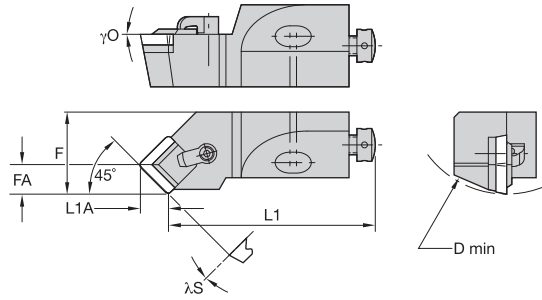

**■ CSSP 45°**

订货号	目录编号	D min	F	L1	FA	L1A	λS°	γ0°	刀片
右手 1261379	CSSPR10CA09	40	14,0	44	6,5	6,1	0.0	0.0	SP..090308/SP..322
左手 3331143	CSSPL10CA09	40	14,0	44	6,5	6,1	0.0	0.0	SP..090308/SP..322

注: 根据 D 最小值和已选刀片尺寸选择配件产品。

**■ 配件**

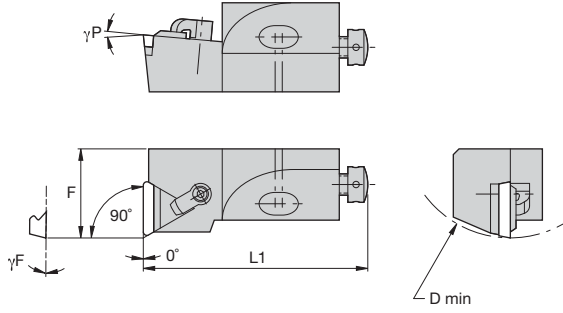
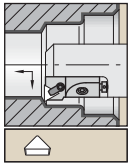
D min	夹具	夹紧螺钉	六角	径向调节螺钉	六角	轴向调节螺钉	安装螺钉	六角	垫片
40	<b>CKM34</b>	<b>STCM38</b>	2 mm	<b>KUAM28</b>	2 mm	<b>KUAM30</b>	<b>191.405</b>	4 mm	<b>CSWM 060 050</b>



■ CTFP 90°

订货号	目录编号	D min	F	L1	$\gamma_F^\circ$	$\gamma_P^\circ$	刀片
右手							
2116588	CTFPR10CA11	40	14,0	50	0.0	5.0	TP..110304/TP..221
1746442	CTFPR12CA16	50	20,0	55	0.0	5.0	TP..160308/TP..322
2582207	CTFPR20CA22	70	25,0	70	0.0	5.0	TP..220408/TP..432
左手							
2114034	CTFPL10CA11	40	14,0	50	0.0	5.0	TP..110304/TP..221

■ 配件



D min	垫片	垫片螺钉	六角	夹具	夹紧螺钉	六角	径向调节螺钉	六角	轴向调整螺钉	安装螺钉	安装螺钉	六角	垫片
40	-	-	-	CKM34	STCM38	2 mm	KUAM28	2 mm	KUAM30	191.405	-	4 mm	CSWM 060 050
50	-	-	-	CKM34	STCM38	2 mm	KUAM22	2 mm	KUAM31	-	191.406	4 mm	CSWM 060 050
70	SM837	MS125	2.5 mm	CKM35	STCM8	4 mm	KUAM25	2.5 mm	KUAM32	-	191.407	5 mm	CSWM 080 050

# Beyond™ Drive™ 刀片

- 提高生产率。
- 涂层后处理可以减少涂层应力，提高涂层的粘着性能。
- 卓越的韧性和耐磨性。
- 更好的刀片磨损识别性能。

beyond DRIVE™

精磨刀片上下定位面  
• 保证高精度的刀片定位面

## 超细晶粒铝涂层

- 具有很好的涂层完整性，可以进行高速切削。
- 在进行高温切削加工时具有更高的加工效率和可靠性。

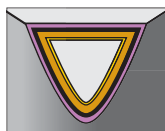

TiN/MT-TiCN/TiCN/Al<sub>2</sub>O<sub>3</sub>/TiCN

## 涂层去应力处理

- 改善了刀刃的韧性。
- 超长并可预测的刀具寿命。
- 减少切深处出现凹口的可能。
- 可用于多种加工应用。

## 精密抛光刀刃

- 改善了刀刃的韧性。
- 具有外表面光滑的特点，可减少切削力、摩擦，以及工件粘着的现象。

联系肯纳金属授权经销商，或是登录  
[kennametal.com](http://kennametal.com)，了解更多的产品优势。

 KENNAMETAL®

[kennametal.com](http://kennametal.com)

关于PDF内容涉及《广告法》违禁词、极限词用语作废声明  
本PDF文字、图片中涉及《广告法》中违禁词、极限词等词语的，在此申明一律作废，不作为产品介绍的依据。谢谢配合。