





刃倾角和左手螺旋槽丝锥	系列	材质/ 涂层	柄部/规格	● 优选 ○ 备选						
				P	M	K	N	S	H	
	T320	KC7542	6535 HA	●		○				
	T320	KC7542	6535 HA	●		○				
	T321	KC7542	6535 HA	●		○				
	T620	KP6525 KM6515	DIN 371, 374, 376	●	●	○	○			
	T621	KP6525 KM6515	DIN 371, 374, 376	●	●	○	○			
	T620	KP6525	DIN 376	●		●				
	T620	KP6525	XL	●		●				
	T620	KP6525	DIN 371, 376	●	○	○				
	T621	KP6525	DIN 371, 376	●	○	○				
	T670	KSN38	DIN 371, 376				●			
	T600	KSP21	DIN 371, 374, 376	●				○		
	T820	KSP32 KSP39	DIN 371, 374, 376	●	○	●	○			
	T820	KSP39	DIN 371, 376	○	○	○				
	T820	KSU31 KSU30	JIS	●	○	○	○			

	尺寸范围	孔		切削锥		螺旋角	冷却方式		页码	推荐切削参数
		通孔	盲孔	类型	代码		外冷	通孔		
										
	3/8-1/2"	●		D型切削锥	D	L15°	●		M4	M98
	M6-M16	●		D型切削锥	D	L15°	●		M4	M98
	M10-M16	●		D型切削锥	D	L15°		●	M5	M98
	M3-M20	●		D型切削锥	D	L15°	●		M6	M98
	M5-M18	●		D型切削锥	D	L15°		●	M7	M98
	M24-M42	●		D型切削锥	D	L15°	●		M8	M98
	M24-M42	●		D型切削锥	D	L15°		●	M9	M98
	#6-1/2"	●		D型切削锥	D	L15°	●		M10	M98
	1/4-1/2"	●		D型切削锥	D	L15°		●	M11	M98
	M3-M16	●		D型切削锥	B	0°	●		M12	M98
	M3-M20	●		D型切削锥	B	0°	●		M13	M98
	M2-M36	●		D型切削锥	B	0°	●		M14-M15	M99
	#4-1"	●		D型切削锥	B	0°	●		M16-M17	M99
	M3-M20	●		D型切削锥	B	0°	●		M18	M99

螺旋槽丝锥	系列	材质/ 涂层	柄部/规格	● 优选 ○ 备选						
				P	M	K	N	S	H	
	T331	KC7542	6535 HA	●		○				
	T331	KC7542	6535 HA	●		○				
	T630	KP6525, KM6515	DIN 371, 374, 376	●	●	○	○			
	T631	KP6525, KM6515	DIN 371, 374, 376	●	●	○	○			
	T632	KP6525	DIN 371, 374, 376	●		○				
	T633	KP6525	DIN 371, 374, 376	●		○				
	T630	KP6525	DIN 376	●		●				
	T631	KP6525	DIN 376	●		●				
	T630	KP6525	XL	●		●				
	T631	KP6525	XL	●		●				
	T650	KP6525	DIN 376	●		●				
	T651	KP6525	DIN 376	●		●				
	T650	KP6525	XL	●		●				
	T651	KP6525	XL	●		●				
	T630	KP6525	DIN 371, 376	●	○	○				
	T631	KP6525	DIN 371, 376	●	○	○				
	T680	KSN38	DIN 371, 376				●			
	T604	KSH26	DIN 371, 374, 376	●				○		
	T830	KSP32, KSP39	DIN 371, 374, 376	●	○	●	○			
	T832	KSP32, KSP39	DIN 371, 374, 376	●	○	●	○			
	T838	KSU31, KSP39	DIN 371, 374, 376	●	○	○	○			
	T839	KSU31, KSP39	DIN 371, 376	●	○	○	○			
	T830	KSP39	DIN 371, 376	○	○	○				
	T838	KSU31, KSP39	DIN 371, 374, 376	●	○	○	○			
	T830	KSU31, KSU30	JIS	●	○	○	○			

尺寸范围	孔		切削锥		螺旋角	冷却方式		页码	推荐切削参数
	通孔	盲孔	类型	代码		外冷	通孔		
									
1/4-1/2"		●	C型切削锥	C	45°		●	M22	M98
M6-M16		●	C型切削锥	C	45°		●	M23	M98
M3-M20		●	C型切削锥	C	45°	●		M24	M98
M5-M18		●	C型切削锥	C	45°		●	M25	M98
M5-M16		●	E型切削锥	E	45°	●		M26	M98
M5-M16		●	E型切削锥	E	45°		●	M27	M98
M24-M42		●	C型切削锥	C	45°	●		M28	M98
M24-M42		●	C型切削锥	C	45°		●	M29	M98
M24-M42		●	C型切削锥	C	45°	●		M30	M98
M24-M42		●	C型切削锥	C	45°		●	M31	M98
M24-M42		●	C型切削锥	C	15°	●		M32	M98
M24-M42		●	C型切削锥	C	15°		●	M33	M98
M24-M42		●	C型切削锥	C	15°	●		M34	M98
M24-M42		●	C型切削锥	C	15°		●	M35	M98
#6-1/2"		●	C型切削锥	C	45°	●		M36	M98
1/4-1/2"		●	C型切削锥	C	45°		●	M37	M98
M3-M20		●	C型切削锥	C	45°	●		M38	M98
M3-M20		●	C型切削锥	C	42°	●		M39	M98
M2-M36		●	C型切削锥	C	45°	●		M40-M41	M99
M3-M20		●	E型切削锥	E	45°	●		M42	M99
M2-M52		●	C型切削锥	C	45°	●		M43-M44	M99
M3-M20		●	E型切削锥	E	45°	●		M45	M99
#4-1"		●	C型切削锥	C	45°	●		M46, M49	M99
#6-2"		●	C型切削锥	C	45°	●		M47-M48	M99
M3-M20		●	C型切削锥	C	45°	●		M50	M99

直槽丝锥	系列	材质/ 涂层	柄部/规格	● 优选 ○ 备选					
				P	M	K	N	S	H
	T340	KCK17	6535 HA	○		●			
	T340	KCK17	6535 HA	○		●			
	T351	KCK17	6535 HA	○		●			
	T351	KCK17	6535 HA	○		●			
	T351	KCK17	DIN 371, 374, 376	○		●			
	T353	KCK17	DIN 371, 376	○		●			
	T471	KCN14	6535 HA				●		
	T471	KCN14	DIN 371				●		
	T410	KCU36	DIN 371, 374, 376						●
	T640	KP6525	DIN 371, 376			●	●		
	T641	KP6525	DIN 371, 376			●	●		
	T642	KP6525	DIN 371, 374, 376			●	●		
	T643	KP6525	DIN 371, 374, 376			●	●		
	T640	KP6525	DIN 371, 376			●	●		
	T641	KP6525	DIN 371, 376			●	●		





*内冷 1/4", M6 和更大尺寸

尺寸范围	孔		切削锥		螺旋角	冷却方式		页码	推荐切削参数
	通孔	盲孔	类型	代码		外冷	通孔		
									
#6-9/16"	●		D型切削锥	D	0°	●		M54	M98
M4-M20	●		D型切削锥	D	0°	●		M55	M98
#6-3/4"		●	E型切削锥	E	0°		●	M56	M98
M4*-M16		●	E型切削锥	E	0°		●	M57	M98
M6-M14		●	E型切削锥	E	0°		●	M58	M98
M4*-M14		●	C型切削锥	C	0°		●	M59	M98
M6-M14		●	E型切削锥	E	0°		●	M60	M98
M6-M10		●	E型切削锥	E	0°		●	M61	M98
M3-M16		●	C型切削锥	C	0°	●		M62	M98
M4-M22	●	●	C型切削锥	C	0°	●		M63	M98
M5-M20		●	C型切削锥	C	0°		●	M64	M98
M5-M16	●	●	E型切削锥	E	0°	●		M65	M98
M5-M16		●	E型切削锥	E	0°		●	M66	M98
#6-1/2"	●	●	C型切削锥	C	0°	●		M67	M98
1/4-1/2"		●	C型切削锥	C	0°		●	M68	M98

挤压丝锥	系列	材质/ 涂层	柄部/规格	● 优选 ○ 备选					
				P	M	K	N	S	H
	T491	KCN14	6535 HA				●		
	T491	KCN14	DIN 2174				●		
	T622	KSP21, KSN28	DIN 2174	●			●		
	T623	KSP21, KSN28	DIN 2174	●			●		

管用丝锥	系列	材质/ 涂层	柄部/规格	● 优选 ○ 备选					
				P	M	K	N	S	H
	T877	KSU31, KSP39	DIN 5156	●	○	○	○		
	T857	KSU31, KSP39	DIN 5156	●	○	○	○		
	T848	KSU30	DIN 5156	○		○			

	尺寸范围	☒		切削锥		螺旋角	冷却方式		页码	推荐切削参数
		通孔	盲孔	类型	代码		外冷	通孔		
										
M5-M12			●	E型切削锥	E	-		●	M72	M98
M6-M10			●	E型切削锥	E	-		●	M73	M98
M3-M16		●	●	C型切削锥	C	-	●		M74	M98
M5-M16			●	C型切削锥	C	-		●	M75	M98

	尺寸范围	☒		切削锥		螺旋角	冷却方式		页码	推荐切削参数
		通孔	盲孔	类型	代码		外冷	通孔		
										
1/8-1"		●		D型切削锥	B	0°	●		M78	M99
1/8-1"			●	C型切削锥	C	42°	●		M78	M99
1/16-1"		●	●	C型切削锥	C	0°	●		M79	M99

整体硬质合金丝锥识别系统

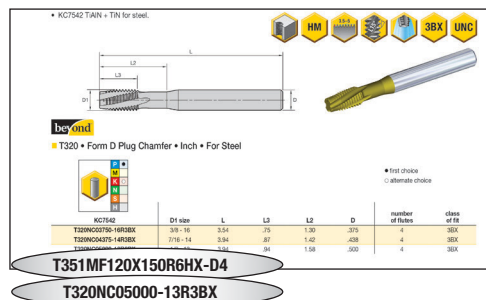

T351MF120X150R6HX-D4

T320NC05000-13R3BX

<p>公制</p> <div style="border: 1px solid black; padding: 5px; width: 80px; margin: 5px auto;">T351</div>	<div style="border: 1px solid black; padding: 5px; width: 80px; margin: 5px auto;">MF</div>	<div style="border: 1px solid black; padding: 5px; width: 80px; margin: 5px auto;">120</div>	<div style="border: 1px solid black; padding: 5px; width: 80px; margin: 5px auto;">X</div>	<div style="border: 1px solid black; padding: 5px; width: 80px; margin: 5px auto;">150</div>	<div style="border: 1px solid black; padding: 5px; width: 80px; margin: 5px auto;">R</div>	<div style="border: 1px solid black; padding: 5px; width: 80px; margin: 5px auto;">6HX</div>	<div style="border: 1px solid black; padding: 5px; width: 80px; margin: 5px auto;">-D4</div>
<p>英制</p> <div style="border: 1px solid black; padding: 5px; width: 80px; margin: 5px auto;">T320</div> <p>丝锥设计</p>	<div style="border: 1px solid black; padding: 5px; width: 80px; margin: 5px auto;">NC</div> <p>螺纹类型</p>	<div style="border: 1px solid black; padding: 5px; width: 80px; margin: 5px auto;">05000</div> <p>螺纹公称直径</p> <p style="font-size: small;">毫米或英寸 (根据产品类型)</p>	<div style="border: 1px solid black; padding: 5px; width: 80px; margin: 5px auto;">-</div>	<div style="border: 1px solid black; padding: 5px; width: 80px; margin: 5px auto;">13</div> <p>螺距</p> <p style="font-size: small;">毫米或TPI (根据产品类型)</p>	<div style="border: 1px solid black; padding: 5px; width: 80px; margin: 5px auto;">R</div> <p>螺纹旋向</p>	<div style="border: 1px solid black; padding: 5px; width: 80px; margin: 5px auto;">3BX</div> <p>公差等级</p>	<div style="border: 1px solid black; padding: 5px; width: 80px; margin: 5px auto;"></div> <p>丝锥尺寸</p>

<p>M = 公制粗牙螺纹 (ISO型)</p> <p>MF = 公制细牙螺纹 (ISO型)</p> <p>NC = 统一标准粗牙螺纹</p> <p>NF = 统一标准细牙螺纹</p>	<p>D1 = DIN 371</p> <p>D4 = DIN 374</p> <p>D6 = DIN 376</p> <p>D74 = DIN 2174</p> <p>毛坯 = 6535 HA</p>
--	---

丝锥设计

T320 = 钢, 通孔, LH 螺旋槽, 整体式

T321 = 钢, 通孔, LH 螺旋槽, 内冷

T331 = 钢, 盲孔, RH 螺旋槽, 内冷

T340 = 铸铁及铸铝, 通孔, 直槽, 整体式

T351 = 铸铁及铸铝, 盲孔, 直槽, 内冷

T353 = 铸铁及铸铝, 盲孔, 直槽, 内冷

T410 = 淬硬钢 55-63 HRC, 通孔及盲孔, 直槽, 整体式

T471 = 铝合金, 盲孔, 直槽, 内冷

T491 = 铝合金, 盲孔, 挤压丝锥, 内冷

HSS-E-PM 丝锥识别系统

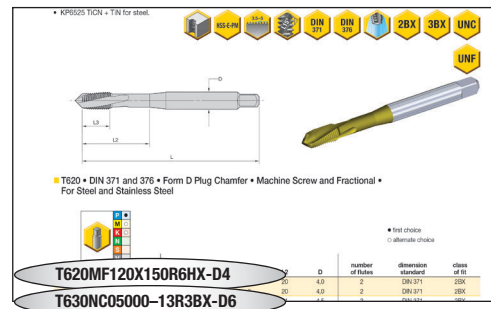

公制	T620	MF	120	X	150	R	6HX	-D4
英制	T630	NC	05000	-	13	R	3BX	-D6
	丝锥设计	螺纹类型	螺纹公称直径		螺距	螺纹旋向	公差等级	丝锥尺寸
			毫米或英寸 (根据产品类型)		毫米或TPI (根据产品类型)			

M = 公制粗牙螺纹 (ISO型)
MF = 公制细牙螺纹 (ISO型)
NC = 统一标准粗牙螺纹
NF = 统一标准细牙螺纹

D1 = DIN 371
D4 = DIN 374
D6 = DIN 376
D74 = DIN 2174
XL = DIN 超长型

丝锥设计

T600 = 钢 32-44 HRC, 通孔, 直槽, 整体式
T604 = 钢 32-44 HRC, 盲孔, , 3 x D, RH 42°螺旋槽, 整体式
T620 = 钢和不锈钢, 通孔, LH螺旋槽, 整体式
T621 = 钢和不锈钢, 通孔, LH螺旋槽, 内冷式
T622 = 钢和铝合金, 盲孔和通孔, 挤压丝锥, 整体式
T623 = 钢和铝合金, 盲孔, 挤压丝锥, 内冷
T630 = 钢和不锈钢, 盲孔, RH螺旋槽, 整体式
T631 = 钢和不锈钢, 盲孔, RH螺旋槽, 内冷
T632 = 钢和不锈钢, 盲孔, RH螺旋槽, 整体式
T633 = 钢和不锈钢, 盲孔, RH螺旋槽, 内冷
T640 = 铸铁及铸铝, 通孔和盲孔, 直槽, 整体式
T641 = 铸铁及铸铝, 盲孔, 直槽, 内冷
T642 = 铸铁及铸铝, 盲孔, 直槽, 整体式
T643 = 铸铁及铸铝, 盲孔, 直槽, 内冷
T650 = 钢和铸铁, 盲孔, RH螺旋槽, 大尺寸, 整体式
T651 = 钢和铸铁, 盲孔, RH螺旋槽, 大尺寸, 内冷
T670 = 铝合金, 通孔, 螺旋槽, 整体式
T680 = 铝合金, 盲孔, RH螺旋槽, 整体式

G0tap HSS-E 丝锥识别系统

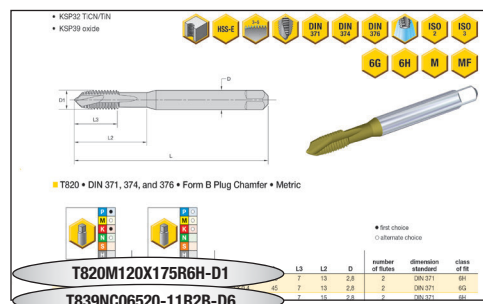

公制	T820	M	120	X	175	R	6H	-D1
英制	T839	NC	06520	-	11	R	2B	-D6
丝锥设计		螺纹类型	螺纹公称直径		螺距	螺纹旋向	公差等级	丝锥尺寸
			毫米或英寸 (根据产品类型)		毫米或TPI (根据产品类型)			

M = 公制粗牙螺纹 (ISO型)
MF = 公制细牙螺纹 (ISO型)
NC = 统一标准粗牙螺纹
NF = 统一标准细牙螺纹
NPT = 美标锥形管螺纹
NPTF = 干式密封美标锥形管螺纹
G = DIN EN ISO 228

D1 = DIN 371
D4 = DIN 374
D6 = DIN 376
D56 = DIN 5156
J = JIS

丝锥设计

T820 = 钢、不锈钢、球墨铸铁、以及铸铝材料; 通孔、刃倾角、整体式
T830 = 钢、不锈钢、球墨铸铁、以及铸铝材料; 盲孔、刃倾角、C型、整体式
T832 = 钢、不锈钢、球墨铸铁、以及铸铝材料; 盲孔、刃倾角、E型、整体式
T838 = 钢、不锈钢、球墨铸铁、以及铸铝材料; 盲孔、刃倾角、TC、C型、整体式
T839 = 钢、不锈钢、球墨铸铁、以及铸铝材料; 盲孔、刃倾角、TC、E型、整体式
T848 = 钢、不锈钢、球墨铸铁、以及铸铝材料、直槽、NPT、NPTF、整体式
T857 = 钢、不锈钢、球墨铸铁、以及铸铝材料、螺旋槽、G、整体式
T877 = 钢、不锈钢、球墨铸铁、以及铸铝材料、刃倾角、G、整体式

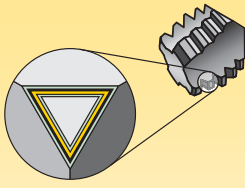

采用在特定材料攻丝加工中具有优化性能的涂层。

P	钢
M	不锈钢
K	铸铁
N	非铁金属
S	高温合金
H	硬材料

耐磨性 ←————→ 韧性

材质

涂层	材质说明		05	10	15	20	25	30	35	40	45
KC7542	带涂层硬质合金，PVD - 复合涂层，采用TiAlN和TiN材料，高强度的硬质合金基体，特别适合攻丝加工应用。在硬度高达 32 HRC 的钢材料和铸铁材料加工中，切削速度为 HSS-E-PM 丝锥的四倍。	P									
		K									
KCK17	采用 PVD AlCrN 复合涂层的细晶粒硬质合金材质。开发的特有涂层材料。在铸铁材料攻丝应用中具有良好的耐磨性。良好的高温硬度性能确保超长使用寿命，攻丝速度比 HSS-E-PM 丝锥提高 4 倍。	P									
		K									
KCN14	带涂层硬质合金，PVD - 双层涂层，基体为细晶粒碳化物。涂层含有低摩擦性的 CrC/C 材料，基层为具有耐磨性的TiN材料。CrC/C 可避免非铁材料对丝锥的擦伤。在对铸铝材料和其它非铁材料的攻丝加工中，具有卓越的加工性能。	P									
		N									
KCU36	带涂层硬质合金。PVD - PVD 双层涂层，底层涂层为耐热 TiAlN 材料，外层涂层为低摩擦性的 MoS ₂ 材料，基体为硬质合金材料。用于硬度为 55-63 HRC 的硬化钢材料加工。	P									
		H									
KSP21	有涂层的HSS-E-PM。PVD - 粉末金属HSS-E基体，涂层为TiN材料。用于对硬度为 32-44 HRC 的钢材料进行攻丝加工，以及硬度为 32 HRC 的钢材料进行螺纹加工。	P									
		M									
KSH26	有涂层的HSS-E-PM。PVD - 粉末金属HSS-E基体，TiN基层涂层和低摩擦性的 MoS ₂ 外层涂层。用于对硬度为 32-44 HRC 的钢材料进行深盲孔加工。	P									
		M									

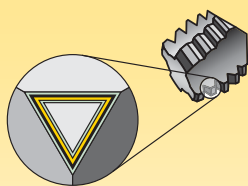

采用在特定材料攻丝加工中具有优化性能的涂层。

P	钢
M	不锈钢
K	铸铁
N	非铁金属
S	高温合金
H	硬材料

耐磨性 ←————→ 韧性

材质

涂层	材质说明		05	10	15	20	25	30	35	40	45	
KSN25	有涂层的HSS-E-PM。PVD — 粉末金属 HSS-E 基体，复合涂层：TiN 基层涂层和DLC外层涂层可避免非铁材料对丝锥的擦伤。用于钛材料的攻丝加工。不适合钢材料加工。	P										
		M										
		K										
		N										
		S										
		H										
KSN28	有涂层的HSS-E-PM。PVD — 粉末金属 HSS-E 基体，DLC 涂层。用于铝材料的挤压成形加工。不适合钢材料加工。	P										
		M										
		K										
		N										
		S										
		H										
KSN38	Coated HSS-E。PVD — 低钒 HSS-E 基体材料，DLC 涂层。用于非铁材料的攻丝加工，具有与加工锻铝材料一样的低切削温度。不适合钢材料加工。	P										
		M										
		K										
		N										
		S										
		H										
KP6525	有涂层的HSS-E-PM。PVD — 具有耐热性和耐磨性的，高钒 - 钴含量的粉末金属 HSS基体。涂层为具有耐磨性的TiCN基层涂层和低摩擦性的TiN外涂层。可用于钢、铸铁、含硅铸铝合金材料的加工。	P										
		M										
		K										
		N										
		S										
		H										
KIM615	有涂层的HSS-E-PM。PVD — 具有耐热性和耐磨性的，高钒 - 钴含量的粉末金属 HSS基体。涂层含有低摩擦性的 CrC/C 材料，基层涂层为具有耐磨性的 TiN 材料。用于不锈钢和非铁材料的攻丝加工。	P										
		M										
		K										
		N										
		S										
		H										
KSP32	高钒 - 钴含量的粉末金属 HSS 基体。涂层为具有耐磨性的 TiCN 基层涂层和低摩擦性的 TiN 外涂层。可用于多种材料的加工，包括钢、不锈钢、球墨铸铁，以及铸铝材料。KSP32 具有良好的耐磨性。	P										
		M										
		K										
		N										
		S										
		H										

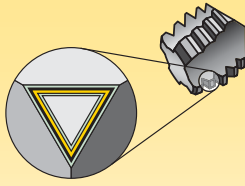

采用在特定材料攻丝加工中具有优化性能的涂层。

P	钢
M	不锈钢
K	铸铁
N	非铁金属
S	高温合金
H	硬材料

耐磨性 ←————→ 韧性

材质

涂层	材质说明		05	10	15	20	25	30	35	40	45
KSMN34	高钨 HSS-E 基体材料，涂层材料包含耐磨 TiN 底层涂层和低摩擦系数的 CrC 表面涂层。用于不锈钢和非铁材料的攻丝加工。										
		M									
		N									
KSU31	带涂层 HSS-E 基体，涂层材料为 TiN PVD。可用于多种材料的加工，包括钢、不锈钢、球墨铸铁，以及铸铝材料。	P									
		M									
		K									
		N									
KSP39	HSS-E 基体，表面经过黑色氧化物处理。可用于多种材料加工，包括钢、不锈钢、以及球墨铸铁材料。不推荐用于非铁金属材料的加工。	P									
		M									
		K									
KSU30	非涂层 HSS-E 材质，表面为亮色。用于易加工材料的一般用途加工。	P									
		M									
		K									
		N									

➤ 直槽丝锥

用于通孔和盲孔加工的高性能丝锥

- 铸铁。
- 铸铝。



高性能 Beyond™ 整体硬质合金丝锥

- 直槽设计，用于铸铁、铸铝，以及淬硬钢材料的通孔和盲孔攻丝应用。
- 与常规高速钢丝锥产品相比，加工速度及使用寿命都可提高 4 倍。
- 非常适合长期项目的加工应用，减少换刀次数意味着生产率的提高。
- 可在配置同步或刚性攻丝控制系统的 CNC 机床上使用，可以使用高精度刀柄。

高性能 Beyond™ HSS-E-PM 丝锥

- 直槽设计，用于铸铁、铸铝，以及淬硬钢材料的通孔和盲孔攻丝应用。
- 与整体硬质合金丝锥相比，具有更高的强度，和更广泛的应用。
- 与常规 HSS-E 丝锥相比，具有更快的攻丝速度，和更长的使用寿命。
- 可用于配有刚性或同步丝锥夹头的常规型或同步攻丝机床。



• KCK17 AICrTiN 涂层, 用于铸铁材料加工。

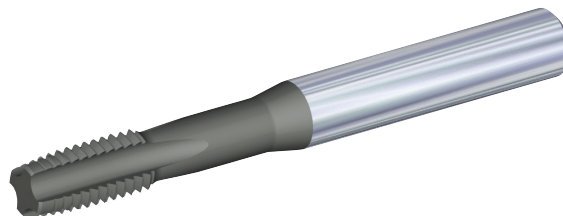
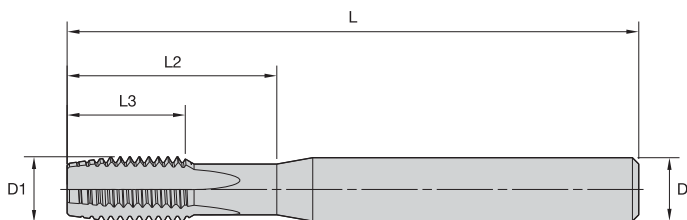

■ T340 • D 型切削锥 • 英制 • 整体硬质合金 • 用于铸铁材料

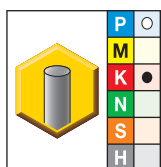

● 优选
○ 备选

KCK17	D1 尺寸	L	L3	L2	D	刃数	公差等级
T340NC#6-32R3BX	6 - 32	2.36	.28	.55	.2500	3	3BX
T340NC#8-32R3BX *	8 - 32	2.36	.28	.63	.2500	3	3BX
T340NC#10-24R3BX	10 - 24	2.36	.35	.79	.2500	3	3BX
T340NF#10-32R3BX	10 - 32	2.36	.35	.79	.2500	3	3BX
T340NC02500-20R3BX	1/4 - 20	2.76	.59	.94	.2500	4	3BX
T340NC03125-18R3BX	5/16 - 18	3.15	.67	1.26	.3125	4	3BX
T340NC03750-16R3BX	3/8 - 16	3.54	.75	1.57	.3750	4	3BX
T340NF03750-24R3BX	3/8 - 24	3.54	.75	1.57	.3750	4	3BX
T340NC05000-13R3BX	1/2 - 13	3.94	.94	1.89	.5000	4	3BX
T340NF05000-20R3BX	1/2 - 20	3.94	.94	1.89	.5000	4	3BX
T340NF05625-18R3BX	9/16 - 18	4.33	1.02	2.21	.5000	4	3BX

注: *按订单生产标准型产品。适用于标准定价、交期按实际生产周期而定, 以及最低订购量的规定

刀杆公差等级	
D	公差 h6
.250-375	+0, -.0004
.438-625	+0, -.0004

• KCK17 AlCrTiN 涂层, 用于铸铁材料加工。

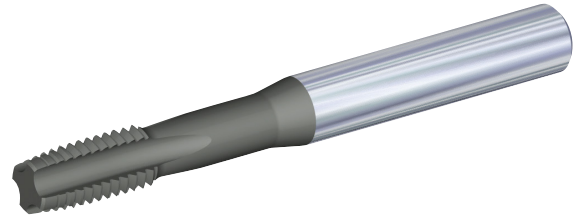
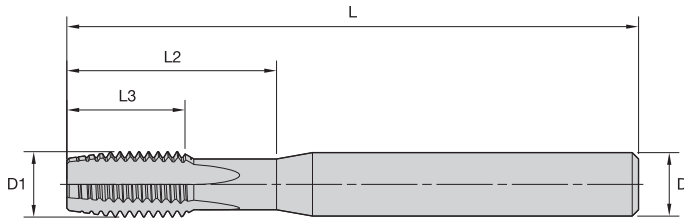

■ T340 • D 型切削锥 • 公制 • 整体硬质合金 • 用于铸铁材料

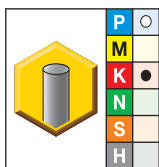

● 优选
○ 备选

KCK17	D1 尺寸	L	L3	L2	D	刃数	公差等级
T340M040X070R6HX	M4 X 0,7	60	6	16	6,0	3	6HX
T340M050X080R6HX	M5 X 0,8	60	7	20	6,0	3	6HX
T340M060X100R6HX	M6 X 1	70	12	24	6,0	4	6HX
T340M080X125R6HX	M8 X 1,25	80	15	32	8,0	4	6HX
T340MF100X100R6HX	M10 X 1	90	18	40	10,0	4	6HX
T340M100X150R6HX	M10 X 1,5	90	18	40	10,0	4	6HX
T340MF120X150R6HX	M12 X 1,5	100	21	48	12,0	4	6HX
T340M120X175R6HX	M12 X 1,75	100	21	48	12,0	4	6HX
T340MF140X150R6HX	M14 X 1,5	110	24	56	12,0	4	6HX
T340M140X200R6HX	M14 X 2	110	24	56	12,0	4	6HX
T340M160X200R6HX	M16 X 2	110	24	64	14,0	4	6HX
T340M200X250R6HX	M20 X 2,5	140	30	80	18,0	5	6HX

刀杆公差等级

D	公差 h6
6	+0, -0,008
8-10	+0, -0,009
12-16	+0, -0,011



• KCK17 AICrTiN 涂层, 用于铸铁材料加工。

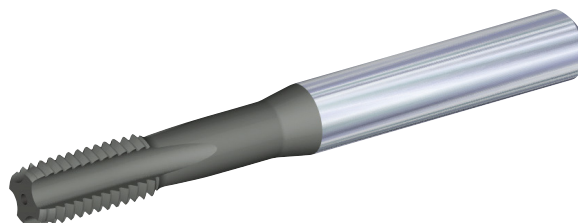
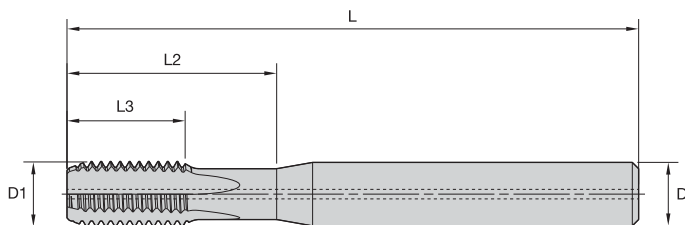

■ T351 • E 型切削锥 • 内冷 1/4" 和更大尺寸 • 英制 • 整体硬质合金 • 用于铸铁材料

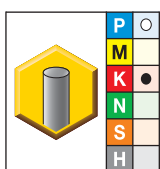

● 优选
○ 备选

KCK17	D1 尺寸	L	L3	L2	D	刃数	公差等级
T351NC#6-32R3BX *	6 - 32	2.36	.28	.55	.2500	3	3BX
T351NC#8-32R3BX	8 - 32	2.36	.28	.63	.2500	3	3BX
T351NF#10-32R3BX *	10 - 32	2.36	.35	.79	.2500	3	3BX
T351NC02500-20R3BX	1/4 - 20	2.76	.59	.95	.2500	4	3BX
T351NC03125-18R3BX	5/16 - 18	3.15	.67	1.26	.3125	4	3BX
T351NC03750-16R3BX	3/8 - 16	3.54	.75	1.57	.3750	4	3BX
T351NC04375-14R3BX	7/16 - 14	3.94	.87	1.73	.4375	4	3BX
T351NC05000-13R3BX	1/2 - 13	3.94	.94	1.89	.5000	4	3BX
T351NC06250-11R3BX	5/8 - 11	4.33	1.10	2.52	.5625	5	3BX
T351NC07500-10R3BX	3/4 - 10	4.92	1.22	3.01	.6250	5	3BX

注: *按订单生产标准型产品。适用于标准定价、交期按实际生产周期而定, 以及zui低订购量的规定

D	公差 h6
.250-375	+0, -.0004
.438-.625	+0, -.0004

• KCK17 AICrTiN 涂层, 用于铸铁材料加工。

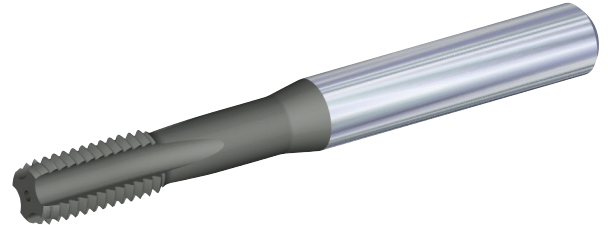
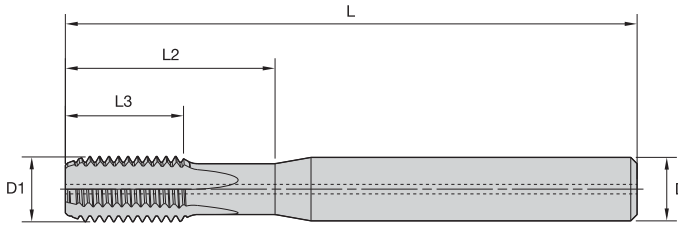

■ T351 • E 型切削锥 • 内冷 M6 和更大尺寸 • 公制 • 整体硬质合金 • 用于铸铁材料

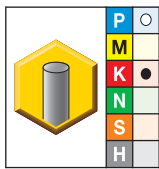

● 优选
○ 备选

KCK17	D1 尺寸	L	L3	L2	D	刃数	公差等级
T351M040X070R6HX *	M4 X 0,7	60	6	16	6,0	3	6HX
T351M050X080R6HX	M5 X 0,8	60	7	20	6,0	3	6HX
T351M060X100R6HX	M6 X 1	70	12	24	6,0	4	6HX
T351M080X125R6HX	M8 X 1,25	80	15	32	8,0	4	6HX
T351MF100X100R6HX	M10 X 1	90	18	40	10,0	4	6HX
T351M100X150R6HX	M10 X 1,5	90	18	40	10,0	4	6HX
T351MF120X150R6HX	M12 X 1,5	100	21	48	12,0	4	6HX
T351M120X175R6HX	M12 X 1,75	100	21	48	12,0	4	6HX
T351MF140X150R6HX	M14 X 1,5	110	24	56	12,0	4	6HX
T351M140X200R6HX	M14 X 2	110	24	56	12,0	4	6HX
T351M160X200R6HX	M16 X 2	110	24	64	14,0	4	6HX

注: *按订单生产标准型产品。适用于标准定价、交期按实际生产周期而定, 以及zui低订购量的规定

刀杆公差等级

D	公差 h6
6	+0, -0,008
8-10	+0, -0,009
12-16	+0, -0,011

- KCK17 AlCrTiN 涂层, 用于铸铁材料加工。

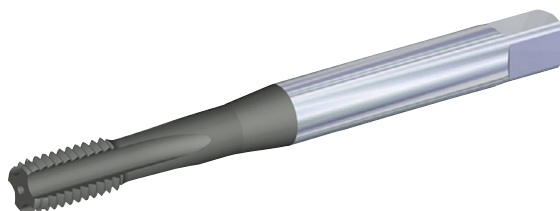
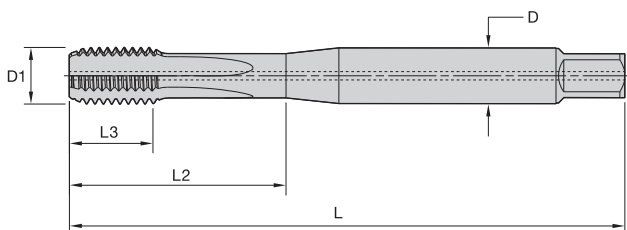
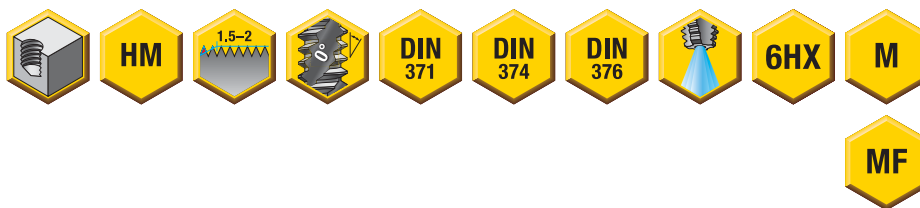

■ T351 • DIN 371, 374, 和 376 • E 型切削锥 • 内冷 • 公制 • 整体硬质合金 • 用于铸铁材料

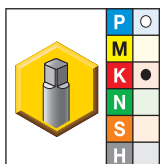

- 优选
- 备选

KCK17	D1 尺寸	L	L3	L2	D	刃数	尺寸标准	公差等级
T351M060X100R6HX-D1	M6 X 1	80	10	30	6,0	4	DIN 371	6HX
T351M070X100R6HX-D1	M7 X 1	80	10	30	7,0	4	DIN 371	6HX
T351M080X125R6HX-D1	M8 X 1,25	90	13	35	8,0	4	DIN 371	6HX
T351M090X125R6HX-D1	M9 X 1,25	90	13	35	9,0	4	DIN 371	6HX
T351MF100X100R6HX-D4	M10 X 1	90	10	35	7,0	4	DIN 374	6HX
T351MF100X125R6HX-D4	M10 X 1,25	100	15	39	7,0	4	DIN 374	6HX
T351M100X150R6HX-D1	M10 X 1,5	100	15	39	10,0	4	DIN 371	6HX
T351MF120X125R6HX-D4	M12 X 1,25	100	15	39	9,0	4	DIN 374	6HX
T351MF120X150R6HX-D4	M12 X 1,50	100	15	39	9,0	4	DIN 374	6HX
T351M120X175R6HX-D6	M12 X 1,75	110	18	44	9,0	4	DIN 376	6HX
T351MF140X125R6HX-D4	M14 X 1,25	100	15	47	11,0	4	DIN 374	6HX
T351MF140X150R6HX-D4	M14 X 1,5	100	15	47	11,0	4	DIN 374	6HX
T351M140X200R6HX-D6	M14 X 2	110	20	52	11,0	4	DIN 376	6HX

刀杆公差等级

D	公差 h6
3-6	+0, -0,008
>6-10	+0, -0,009
>10-18	+0, -0,011
>18-30	+0, -0,013
>30-50	+0, -0,016

- KCK17 AlCrTiN 涂层, 用于铸铁材料加工。

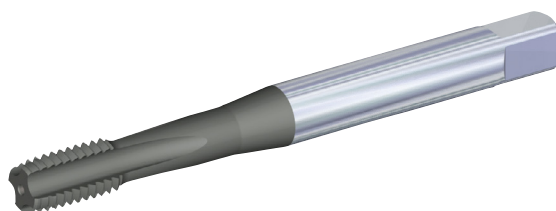
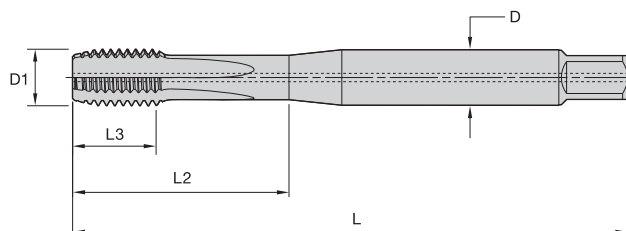

■ T353 • DIN 371 和 376 • C 型切削锥 • 内冷 M6 和更大尺寸 • 公制 • 整体硬质合金 • 用于铸铁材料

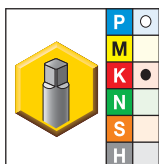

- 优选
- 备选

KCK17	D1 尺寸	L	L3	L2	D	刃数	尺寸标准	公差等级
T353M040X070R6HX-D1	M4 X 0,7	63	10	21	4,5	3	DIN 371	6HX
T353M050X080R6HX-D1	M5 X 0,8	70	10	25	6,0	3	DIN 371	6HX
T353M060X100R6HX-D1	M6 X 1	80	10	30	6,0	4	DIN 371	6HX
T353M080X125R6HX-D1	M8 X 1,25	90	13	35	8,0	4	DIN 371	6HX
T353M100X150R6HX-D1	M10 X 1,5	100	15	39	10,0	4	DIN 371	6HX
T353M120X175R6HX-D6	M12 X 1,75	110	18	44	9,0	4	DIN 376	6HX
T353M140X200R6HX-D6	M14 X 2	110	20	52	11,0	4	DIN 376	6HX

刀杆公差等级

D	公差 h6
3-6	+0, -0,008
>6-10	+0, -0,009
>10-18	+0, -0,011
>18-30	+0, -0,013
>30-50	+0, -0,016

• KCN14 TiN + CrC/C 用于铝合金材料加工.

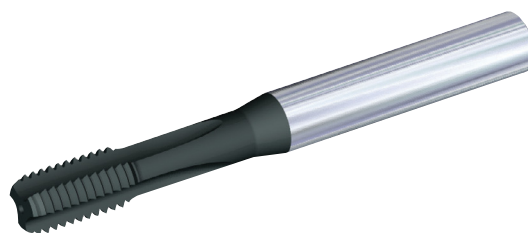
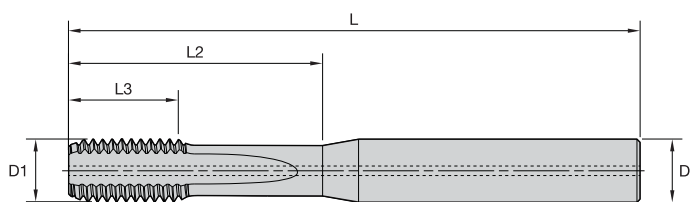

■ T471 • E 型切削锥 • 内冷 • 公制 • 整体硬质合金 • 用于铝合金材料加工

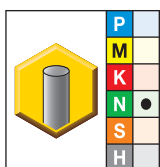

● 优选
○ 备选

KCN14	D1 尺寸	L	L3	L2	D	刃数	公差等级
T471M060X100R6HX	M6 X 1	70	12	24	6,0	3	6HX
T471M080X125R6HX	M8 X 1,25	80	15	32	8,0	3	6HX
T471M100X150R6HX	M10 X 1,5	90	18	40	10,0	3	6HX
T471M120X175R6HX	M12 X 1,75	100	21	48	12,0	3	6HX
T471M140X200R6HX	M14 X 2	110	24	56	12,0	4	6HX

刀杆公差等级

D	公差 h6
6	+0, -0,008
8-10	+0, -0,009
12-16	+0, -0,011

攻丝

• KCN14 TiN + CrC/C 用于铝合金材料加工.

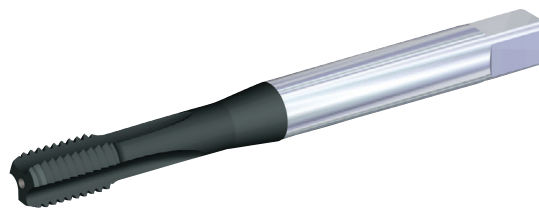
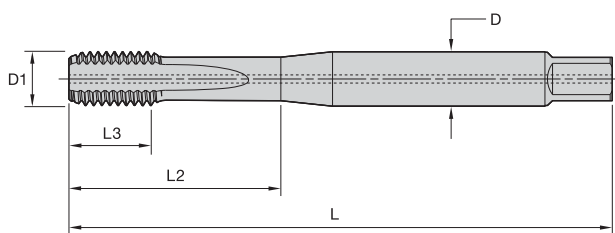

beyond

■ T471 • DIN 371 • E 型切削锥 • 内冷 • 公制 • 整体硬质合金 • 用于铝合金材料加工

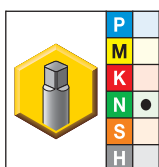

● 优选
○ 备选

KCN14	D1 尺寸	L	L3	L2	D	刃数	尺寸标准	公差等级
T471M060X100R6HX-D1	M6 X 1	80	10	30	6,0	3	DIN 371	6HX
T471M080X125R6HX-D1	M8 X 1,25	90	10	35	8,0	3	DIN 371	6HX
T471M100X150R6HX-D1	M10 X 1,5	100	15	39	10,0	3	DIN 371	6HX

刀杆公差等级

D	公差 h6
3-6	+0, -0,008
>6-10	+0, -0,009
>10-18	+0, -0,011
>18-30	+0, -0,013
>30-50	+0, -0,016

攻丝

- KCU36 TiAlN/MoS₂ 涂层 用于 55-63 HRC 钢材料的攻丝加工。

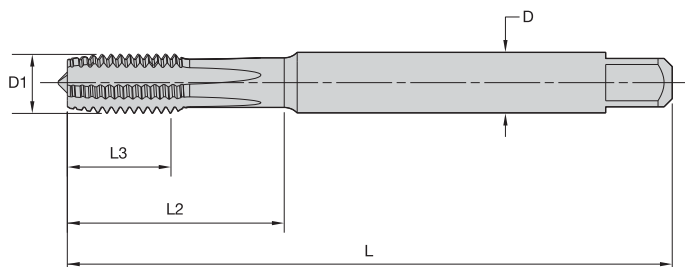

■ T410 • DIN 371, 374, 和 376 • C 型切削锥 • 公制 • 用于硬钢材料加工

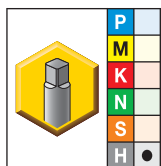

- 优选
- 备选

KCU36	D1 尺寸	L	L3	L2	D	刃数	尺寸标准	公差等级
T410M030X050R6HX-D1	M3 X 0,5	63	6	18	4,5	4	DIN 371	6HX
T410M040X070R6HX-D1	M4 X 0,7	63	8	20	4,5	4	DIN 371	6HX
T410M050X080R6HX-D1	M5 X 0,8	70	10	26	6,0	4	DIN 371	6HX
T410M060X100R6HX-D1	M6 X 1	80	12	28	6,0	4	DIN 371	6HX
T410MF080X100R6HX-D4 *	M8 X 1	90	15	35	8,0	5	DIN 374	6HX
T410M080X125R6HX-D1	M8 X 1,25	90	15	35	8,0	5	DIN 371	6HX
T410MF100X100R6HX-D4 *	M10 X 1	100	18	38	10,0	5	DIN 374	6HX
T410M100X150R6HX-D1	M10 X 1,5	100	18	38	10,0	5	DIN 371	6HX
T410MF120X150R6HX-D4	M12 X 1,5	110	21	41	12,0	5	DIN 374	6HX
T410M120X175R6HX-D6	M12 X 1,75	110	21	41	12,0	5	DIN 376	6HX
T410MF140X150R6HX-D4	M14 X 1,5	110	24	44	14,0	5	DIN 374	6HX
T410M140X200R6HX-D6	M14 X 2	110	24	44	14,0	6	DIN 376	6HX
T410MF160X150R6HX-D4	M16 X 1,5	110	24	44	16,0	5	DIN 374	6HX

注: *按订单生产标准型产品。适用于标准定价、交期按实际生产周期而定, 以及zui低订购量的规定

刀杆公差等级

D	公差 h9
1-3	+0, -0,025
3,5-6	+0, -0,030
7-10	+0, -0,036
11-18	+0, -0,043

- KP6525 TiCN + TiN 涂层, 用于铸铁和铸铝合金材料加工。

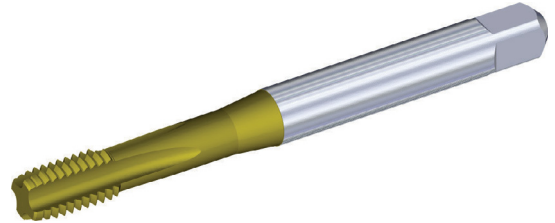
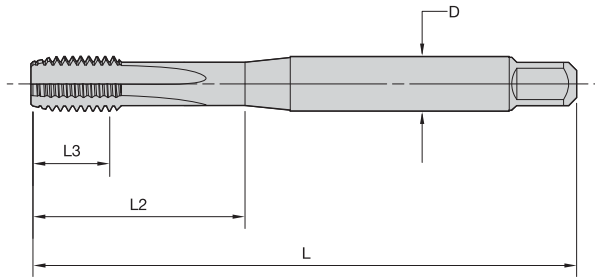

■ T640 • DIN 371 和 376 • C 型切削锥 • 公制 • 用于铸铁和铸铝合金材料加工

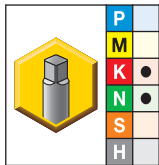

- 优选
- 备选

KP6525	D1 尺寸	L	L3	L2	D	刃数	尺寸标准	公差等级
T640M040X070R6HX-D1	M4 X 0,7	63	10	21	4,5	3	DIN 371	6HX
T640M050X080R6HX-D1	M5 X 0,8	70	10	25	6,0	3	DIN 371	6HX
T640M060X100R6HX-D1	M6 X 1	80	10	30	6,0	4	DIN 371	6HX
T640M080X125R6HX-D1	M8 X 1,25	90	13	35	8,0	4	DIN 371	6HX
T640M100X150R6HX-D1	M10 X 1,5	100	15	39	10,0	4	DIN 371	6HX
T640M120X175R6HX-D6	M12 X 1,75	110	18	44	9,0	4	DIN 376	6HX
T640M140X200R6HX-D6	M14 X 2	110	20	52	11,0	4	DIN 376	6HX
T640M160X200R6HX-D6	M16 X 2	110	20	51	12,0	4	DIN 376	6HX
T640M180X250R6HX-D6	M18 X 2,5	125	25	58	14,0	4	DIN 376	6HX
T640M200X250R6HX-D6	M20 X 2,5	140	25	64	16,0	4	DIN 376	6HX
T640M220X250R6HX-D6	M22 X 2,5	140	25	70	18,0	4	DIN 376	6HX

刀杆公差等级

D	公差 h6
6	+0, -0,008
8-10	+0, -0,009
12-16	+0, -0,011

- KP6525 TiCN + TiN 涂层, 用于铸铁和铸铝合金材料加工。

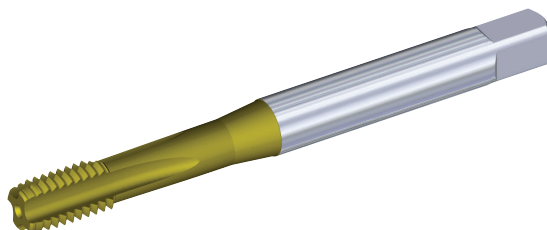
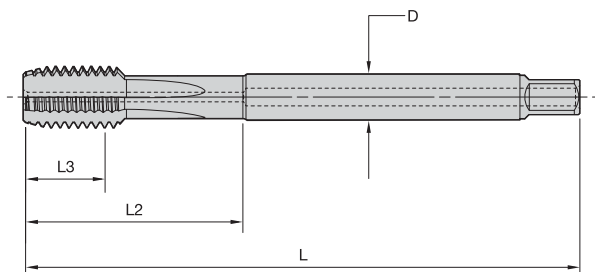

■ T641 • DIN 371 和 376 • C 型切削锥 • 内冷 • 公制 • 用于铸铁和铸铝合金材料加工

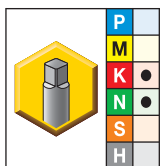

- 优选
- 备选

KP6525	D1 尺寸	L	L3	L2	D	刃数	尺寸标准	公差等级
T641M050X080R6HX-D1	M5 X 0,8	70	10	25	6,0	3	DIN 371	6HX
T641M060X100R6HX-D1	M6 X 1	80	10	30	6,0	4	DIN 371	6HX
T641M080X125R6HX-D1	M8 X 1,25	90	13	35	8,0	4	DIN 371	6HX
T641M100X150R6HX-D1	M10 X 1,5	100	15	39	10,0	4	DIN 371	6HX
T641M120X175R6HX-D6	M12 X 1,75	110	18	44	9,0	4	DIN 376	6HX
T641M140X200R6HX-D6	M14 X 2	110	20	52	11,0	4	DIN 376	6HX
T641M160X200R6HX-D6	M16 X 2	110	20	51	12,0	4	DIN 376	6HX
T641M180X250R6HX-D6	M18 X 2,5	125	25	58	14,0	4	DIN 376	6HX
T641M200X250R6HX-D6	M20 X 2,5	140	25	64	16,0	4	DIN 376	6HX

刀杆公差等级

D	公差 h6
6	+0, -0,008
8-10	+0, -0,009
12-16	+0, -0,011

- KP6525 TiCN + TiN 涂层,
用于铸铁和铸铝合金材料加工。

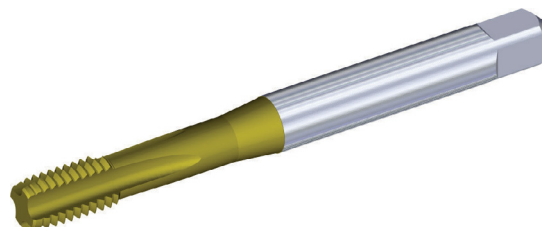
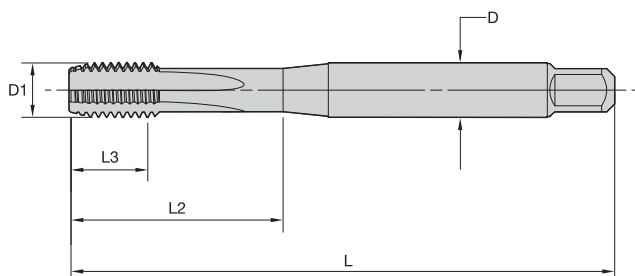
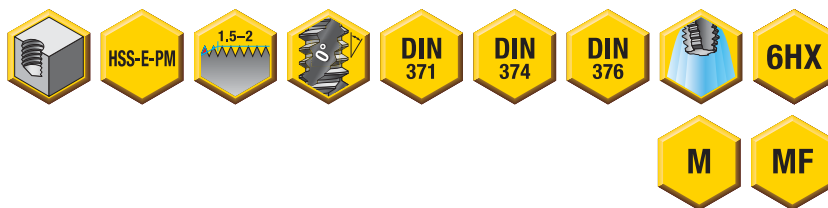

■ T642 • DIN 371, 374, 和 376 • E 型切削锥 • 公制 • 用于铸铁和铸造硅铝合金材料加工

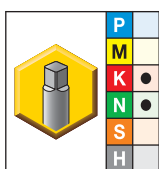

- 优选
- 备选

KP6525	D1 尺寸	L	L3	L2	D	刃数	尺寸标准	公差等级
T642M050X080R6HX-D1	M5 X 0,8	70	10	25	6,0	3	DIN 371	6HX
T642M060X100R6HX-D1	M6 X 1	80	10	30	6,0	4	DIN 371	6HX
T642M080X125R6HX-D1	M8 X 1,25	90	13	35	8,0	4	DIN 371	6HX
T642M100X150R6HX-D1	M10 X 1,5	100	15	39	10,0	4	DIN 371	6HX
T642MF120X150R6HX-D4	M12 X 1,5	100	15	39	9,0	4	DIN 374	6HX
T642M120X175R6HX-D6	M12 X 1,75	110	18	44	9,0	4	DIN 376	6HX
T642MF140X150R6HX-D4	M14 X 1,5	100	15	47	11,0	4	DIN 374	6HX
T642M140X200R6HX-D6	M14 X 2	110	20	52	11,0	4	DIN 376	6HX
T642MF160X150R6HX-D4	M16 X 1,5	100	15	46	12,0	4	DIN 374	6HX

刀杆公差等级

D	公差 h6
6	+0, -0,008
8-10	+0, -0,009
12-16	+0, -0,011

- KP6525 TiCN + TiN 涂层, 用于铸铁和铸硅合金材料的攻丝加工。

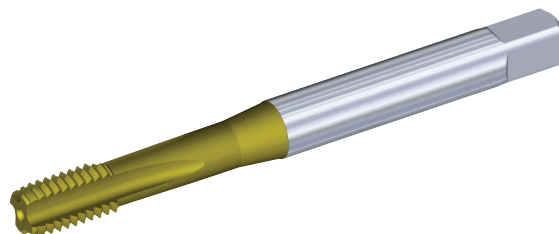
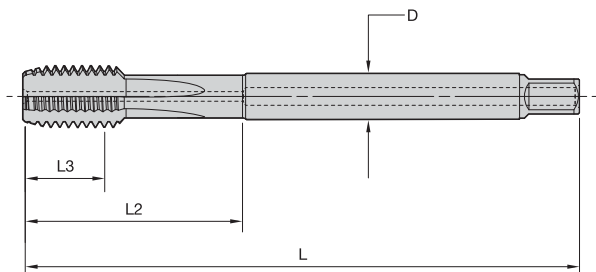
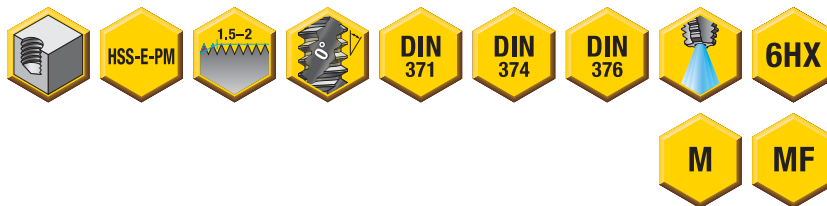

■ T643 • DIN 371, 374, 和 376 • E 型切削锥 • 内冷 • 公制 • 用于铸铁和铸造硅铝合金材料加工

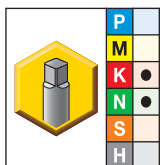

- 优选
- 备选

KP6525	D1 尺寸	L	L3	L2	D	刃数	尺寸标准	公差等级
T643M050X080R6HX-D1	M5 X 0,8	70	10	25	6,0	3	DIN 371	6HX
T643M060X100R6HX-D1	M6 X 1	80	10	30	6,0	4	DIN 371	6HX
T643M080X125R6HX-D1	M8 X 1,25	90	13	35	8,0	4	DIN 371	6HX
T643M100X150R6HX-D1	M10 X 1,5	100	15	39	10,0	4	DIN 371	6HX
T643MF120X150R6HX-D4	M12 X 1,5	100	15	39	9,0	4	DIN 374	6HX
T643M120X175R6HX-D6	M12 X 1,75	110	18	44	9,0	4	DIN 376	6HX
T643MF140X150R6HX-D4	M14 X 1,5	100	15	47	11,0	4	DIN 374	6HX
T643M140X200R6HX-D6	M14 X 2	110	20	52	11,0	4	DIN 376	6HX
T643MF160X150R6HX-D4	M16 X 1,5	100	15	46	12,0	4	DIN 374	6HX

刀杆公差等级

D	公差 h6
6	+0, -0,008
8-10	+0, -0,009
12-16	+0, -0,011

攻丝

- KP6525 TiCN + TiN 涂层, 用于铸铁和铸铝合金材料加工。

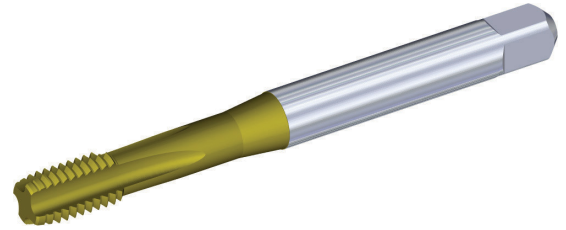
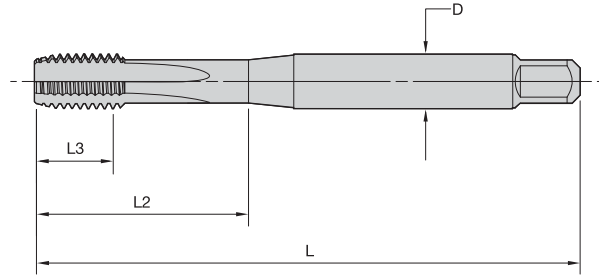
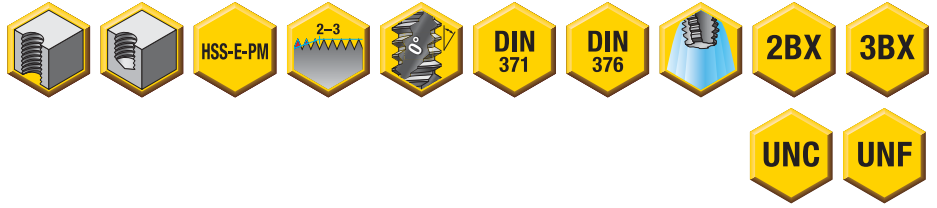

■ T640 • DIN 371 和 376 • C 型切削锥 • 英制机用 • 用于铸铁和铸铝合金材料加工

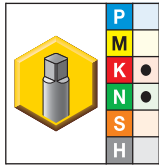

- 优选
- 备选

KP6525	D1 尺寸	L	L3	L2	D	刃数	尺寸标准	公差等级
T640NC#06-32R2BX-D1	6 - 32	56	9	20	4,0	3	DIN 371	2BX
T640NF#06-40R2BX-D1 *	6 - 40	56	9	20	4,0	3	DIN 371	2BX
T640NC#08-32R2BX-D1	8 - 32	63	10	21	4,5	3	DIN 371	2BX
T640NC#10-24R2BX-D1	10 - 24	70	10	25	6,0	3	DIN 371	2BX
T640NF#10-32R2BX-D1	10 - 32	70	10	25	6,0	3	DIN 371	2BX
T640NC02500-20R3BX-D1	1/4 - 20	80	13	30	7,0	4	DIN 371	3BX
T640NF02500-28R3BX-D1	1/4 - 28	80	13	30	7,0	4	DIN 371	3BX
T640NC03125-18R3BX-D1	5/16 - 18	90	13	35	8,0	4	DIN 371	3BX
T640NF03125-24R3BX-D1	5/16 - 24	90	13	35	8,0	4	DIN 371	3BX
T640NC03750-16R3BX-D1	3/8 - 16	100	16	39	10,0	4	DIN 371	3BX
T640NF03750-24R3BX-D1	3/8 - 24	100	16	39	10,0	4	DIN 371	3BX
T640NC04375-14R3BX-D6	7/16 - 14	100	15	41	8,0	4	DIN 376	3BX
T640NF04375-20R3BX-D6	7/16 - 20	100	15	41	8,0	4	DIN 376	3BX
T640NC05000-13R3BX-D6	1/2 - 13	110	20	47	9,0	4	DIN 376	3BX
T640NF05000-20R3BX-D6	1/2 - 20	110	20	47	9,0	4	DIN 376	3BX

注: *按订单生产标准型产品。适用于标准定价、交期按实际生产周期而定, 以及zui低订购量的规定

刀杆公差等级

D 分数制	公差 h6
>3-6	+0, -0,008
>6-10	+0, -0,009
<10-18	+0, -0,011

- KP6525 TiCN + TiN 涂层, 用于铸铁和铸铝合金材料加工。

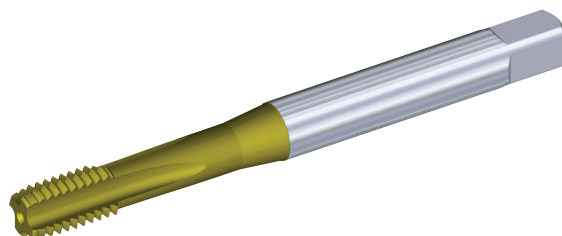
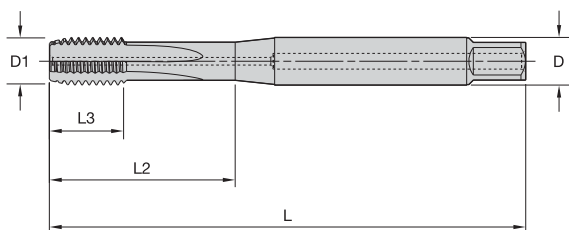

■ T641 • DIN 371 和 376 • C 型切削锥 • 内冷 • 分数制 • 用于铸铁和铸铝合金材料加工

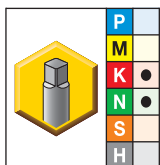



- 优选
- 备选

KP6525	D1 尺寸	L	L3	L2	D	刃数	尺寸标准	公差等级
T641NC02500-20R3BX-D1	1/4 - 20	80	13	30	7,0	4	DIN 371	3BX
T641NF02500-28R3BX-D1	1/4 - 28	80	13	30	7,0	4	DIN 371	3BX
T641NC03125-18R3BX-D1	5/16 - 18	90	13	35	8,0	4	DIN 371	3BX
T641NF03125-24R3BX-D1	5/16 - 24	90	13	35	8,0	4	DIN 371	3BX
T641NC03750-16R3BX-D1	3/8 - 16	100	16	39	10,0	4	DIN 371	3BX
T641NF03750-24R3BX-D1	3/8 - 24	100	16	39	10,0	4	DIN 371	3BX
T641NC04375-14R3BX-D6	7/16 - 14	100	15	41	8,0	4	DIN 376	3BX
T641NF04375-20R3BX-D6	7/16 - 20	100	15	41	8,0	4	DIN 376	3BX
T641NC05000-13R3BX-D6	1/2 - 13	110	20	47	9,0	4	DIN 376	3BX
T641NF05000-20R3BX-D6	1/2 - 20	110	20	47	9,0	4	DIN 376	3BX

刀杆公差等级



D 分数制	公差 h6
>3-6	+0, -0,008
>6-10	+0, -0,009
<10-18	+0, -0,011

■ 高性能丝锥 • 硬质合金 • 公制

材料 分组	 通孔					 盲孔					
	范围 – m/min					范围 – m/min					
	丝锥类型	材质	最小值	初始值	最大值	丝锥类型	材质	最小值	初始值	最大值	
	P	1	T320, T321	KC7542	60	100	130	T331	KC7542	50	70
	2	T320, T321	KC7542	60	90	120	T331	KC7542	40	60	80
	3	T320, T321	KC7542	50	80	100	T331	KC7542	40	60	80
K	1	T340, T353	KC7542, KCK17	70	105	140	T351, T353	KC7542, KCK17	50	70	90
	2	T340, T353	KC7542, KCK17	60	100	130	T351, T353	KC7542, KCK17	50	70	90
	3	T340, T353	KC7542, KCK17	60	90	120	T351, T353	KC7542, KCK17	40	60	80
N	2	-	-	-	-	-	T471, T491	KCN14	60	80	100
	3	-	-	-	-	-	T471, T491	KCN14	50	70	90
	4	-	-	-	-	-	T471, T491	KCN14	40	60	80
H	1	T410	KCU36	1,2	1,5	2,0	T410	KCU36	0,8	1,1	1,4
	2	T410	KCU36	0,6	0,8	1,0	T410	KCU36	0,4	0,5	0,7

注: T321 冷却型丝锥的切削速度可比 T320 非冷却型丝锥的切削速度提高 25%。

■ 高性能丝锥 • HSS-E-PM • 公制

材料 分组	 通孔					 盲孔					
	范围 – m/min					范围 – m/min					
	丝锥类型	材质	最小值	初始值	最大值	丝锥类型	材质	最小值	初始值	最大值	
	P	1	T620	KP6525	20	30	45	T630, T632, T650	KP6525	14	21
		T622	KSP21	18	30	50	T622	KSP21	13	21	35
	2	T620	KP6525	17	25	38	T630, T632, T650	KP6525	12	18	26
		T622	KSP21	15	25	42	T622	KSP21	10	18	29
	3	T620	KP6525	12	15	20	T630, T632, T650	KP6525	8	11	14
	4	T600	KSP21	5	6	8	T604	KSH26	3	4	5
	5	T620	KP6525	12	15	20	T630, T632, T650	KP6525	8	11	14
	6	T600	KSP21	6	8	10	T604	KSH26	4	6	7
M	1	T620	KM6515	12	15	20	T630, T632, T650	KM6515	8	11	14
	2	T620	KM6515	9	12	16	T630, T632, T650	KM6515	6	8	11
	3	T620	KM6515	8	10	13	T630, T632, T650	KM6515	5	7	9
K	1	T640	KP6525	27	35	46	T640, T642	KP6525	19	25	32
	2	T640	KP6525	23	30	39	T640, T642	KP6525	16	21	27
	3	T640	KP6525	19	25	33	T640, T642	KP6525	13	18	23
N	1	T670	KSN38	42	55	72	T680	KSN38	30	39	50
		T622	KSN28	37	55	72	T622	KSN28	26	39	50
	2	T640	KP6525	30	45	59	T640, T642	KP6525	21	32	41
		T622	KSN28	33	50	65	T622	KSN28	23	35	46
	4	T640	KP6525	7	10	15	T640, T642	KP6525	5	7	11
S	1	T620	KP6525	8	12	18	T630, T632	KP6525	6	8	13

注: 在使用冷却型丝锥 (T621, T623, T625, T627, T631, T633, T641, T643, T651) 时, 加工速度可提高 25%。

G0tap™ • 公制

材料 分组	通孔					盲孔						
	范围 - m/min					范围 - m/min						
	丝锥类型	材质	最小值	初始值	最大值	丝锥类型	材质	最小值	初始值	最大值		
P	1	T820	KSU31, KSP32	23	30	38	T830, T832, T838, T839	KSU31, KSP32	15	21	30	
		T820	KSP39, KSU30	11	15	19	T830, T832, T838, T839	KSP39, KSU30	7	11	15	
		T854	KSU31	6	8	10	T854	KSU31	6	8	10	
		T854	KSP39	5	6	8	T854	KSP39	5	6	8	
		T877	KSU31	17	22	28	T857	KSU31	11	15	22	
		T877	KSP39	8	10	13	T857	KSP39	5	7	10	
	2	T848	KSU30	5	6	8	T848	KSU30	3	4	6	
		T820	KSU31, KSP32	18	24	30	T830, T832, T838, T839	KSU31, KSP32	12	17	24	
	3	T820	KSP39, KSU30	11	14	18	T830, T832, T838, T839	KSP39, KSU30	7	10	14	
		T820	KSU31, KSP32	17	22	28	T830, T832, T838, T839	KSU31, KSP32	11	15	22	
		T820	KSP39, KSU30	9	12	15	T830, T832, T838, T839	KSP39, KSU30	6	8	12	
		T846	KSU31	6	8	10	T846	KSU31	6	8	10	
T846		KSU30	4	5	6	T846	KSU30	4	5	6		
T820		KSMN34, KSP32	14	18	23	T830, T832, T838, T839	KSMN34, KSP32	9	13	18		
M	1	T820	KSP39, KSU30	8	10	13	T830, T832, T838, T839	KSP39, KSU30	5	7	10	
		T854	KSU31	6	8	10	T854	KSU31	6	8	10	
		T854	KSP39	4	5	6	T854	KSP39	4	5	6	
		T877	KSU31	9	12	15	T857	KSU31	6	8	11	
		T877	KSP39	5	7	9	T857	KSP39	4	5	7	
		T848	KSU30	4	5	6	T848	KSU30	3	4	6	
	3	T820	KSMN34, KSP32	11	15	19	T830, T832, T838, T839	KSMN34, KSP32	7	11	15	
		T820	KSP39, KSU30	7	9	11	T830, T832, T838, T839	KSP39, KSU30	4	6	9	
	K	1	T846	KSU31	11	15	19	T846	KSU31	11	15	19
			T846	KSU30	6	8	10	T846	KSU30	6	8	10
		2	T820	KSU31, KSP32	16	21	26	T830, T832, T838, T839	KSU31, KSP32	10	15	21
			T820	KSP39, KSU30	9	12	15	T830, T832, T838, T839	KSP39, KSU30	6	8	12
T877			KSU31	14	18	23	T857	KSU31	9	13	18	
T877			KSP39	7	9	11	T857	KSP39	4	6	9	
T848	KSU30	4	5	6	T848	KSU30	2	4	5			
N	1	T820	KSMN34, KSP32	37	49	61	T830, T832, T838, T839	KSMN34, KSP32	24	34	49	
		T820	KSU30	20	27	34	T830, T832	KSU30	13	19	27	
	2	T820	KSMN34, KSP32	30	40	50	T830, T832, T838, T839	KSMN34, KSP32	20	28	40	
		T820	KSU30	16	21	26	T830, T832	KSU30	10	15	21	
		T877	KSU31	17	22	27	T857	KSU31	11	15	22	
		T877	KSP39	8	10	12	T857	KSP39	5	7	10	
		T848	KSU30	10	13	16	T848	KSU30	6	9	13	
		T820	KSMN34, KSP32	37	49	61	T830, T832, T838, T839	KSMN34, KSP32	24	34	49	
	4	T820	KSU30	20	27	33	T830, T832	KSU30	13	19	27	

KSU30 = 亮色
 KSP39 = 氧化黑
 KSU31 = TiN 涂层
 KSP32 = TiCN/TiN 涂层
 KSMN34 = TiN + Cr/C 涂层

攻丝

丝锥及螺纹铣刀的技术资料

以下的技术数据可以为用户提供帮助，解决在攻丝和螺纹铣削中出现的问题。本部分内容包括丝锥型号和应用建议方面的信息，以及用于解决在攻丝和螺纹铣削中出现的常见问题的信息。

包括于该部分:

- 丝锥产品术语的说明。
- 丝锥倒角的说明。
- 各种型号及长度丝锥的规格信息。
- 丝锥限制性数据。
- 不同类型丝锥的切屑处理方法。
- 丝锥应用建议。
- 螺纹公差说明，以及有关公差的信息。
- 有关表面处理和涂层的信息。
- 用于确定丝锥加工速度的指南和切削速度表。
- 故障处理。
- 硬度转换表。
- 肯纳金属攻丝应用图标指南。
- 客户定制丝锥产品表格。
- 丝锥-钻头交互表。

该部分内容可以帮助你更多了解攻丝和螺纹加工应用，从而确保刀具使用性能的大化。

如何应用这些技术数据

在以下的举例中，可以了解如何应用本目录中的技术数据:

故障

- 在不锈钢材料加工应用中，螺纹孔尺寸过大，丝锥寿命缩短。

解决方案

- 参考技术信息部分的故障排除指南，发现解决问题的方法。



定义与角度、尖端、以及排屑槽类型

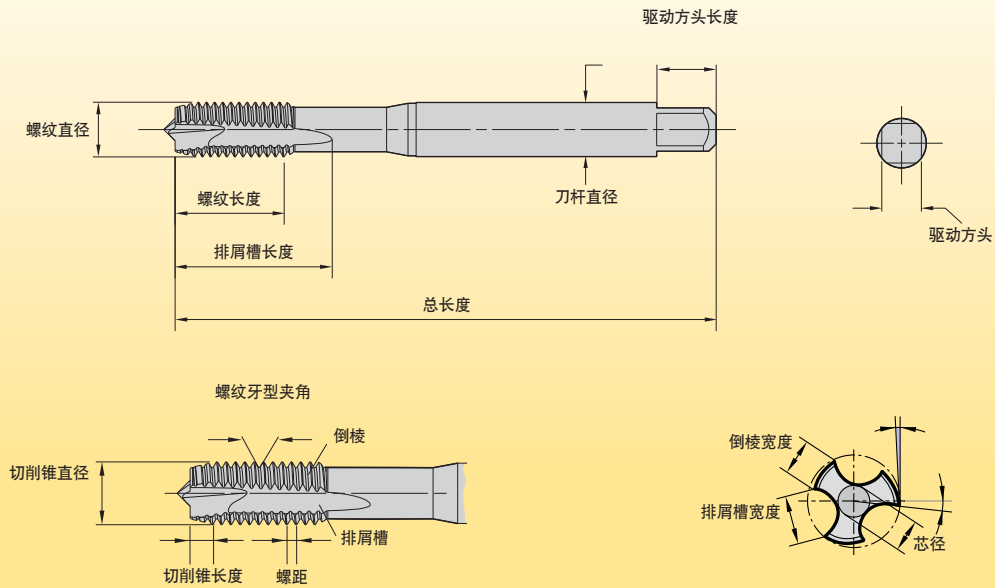

排屑槽类型



直槽、C型切削锥，无刃倾角



右手螺旋槽



直槽、B型切削锥，刃倾角



左手螺旋槽

尖端类型 (符合 DIN 2197/DIN 2175 标准)

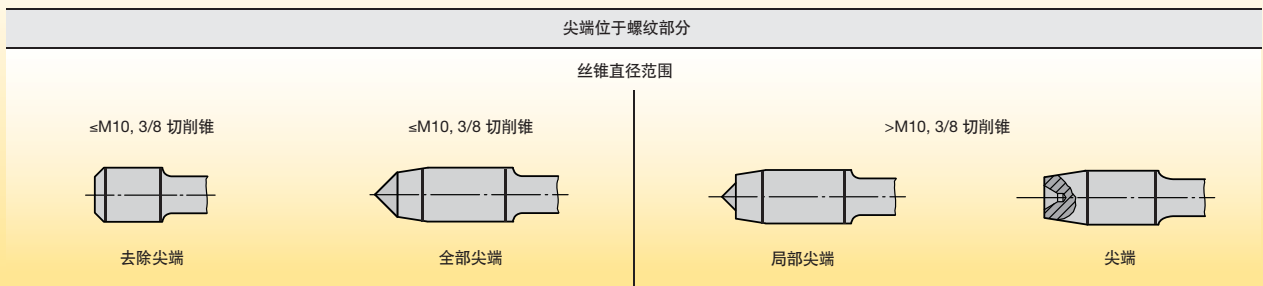

冷却孔类型



轴向冷却液供应系统，带有轴向冷却液出口



轴向冷却液供应系统，带有径向冷却液出口，出口位于排屑槽部位。

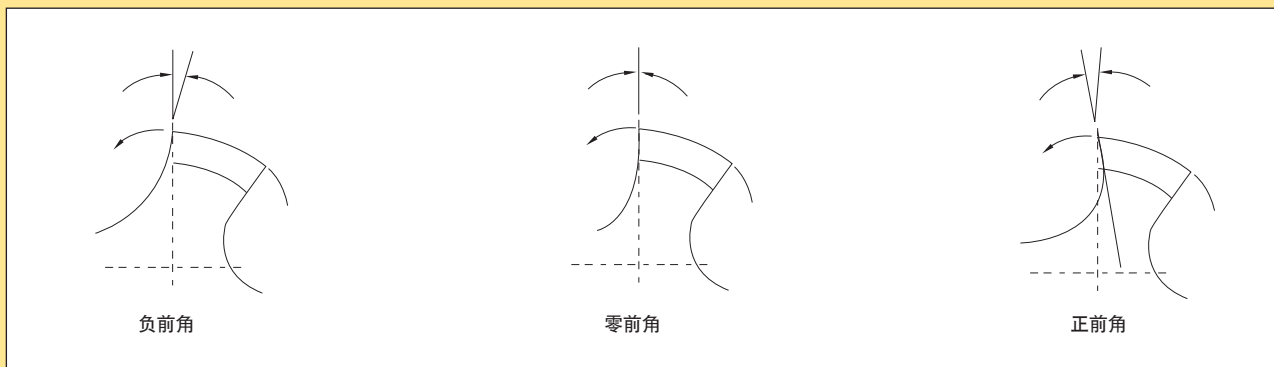
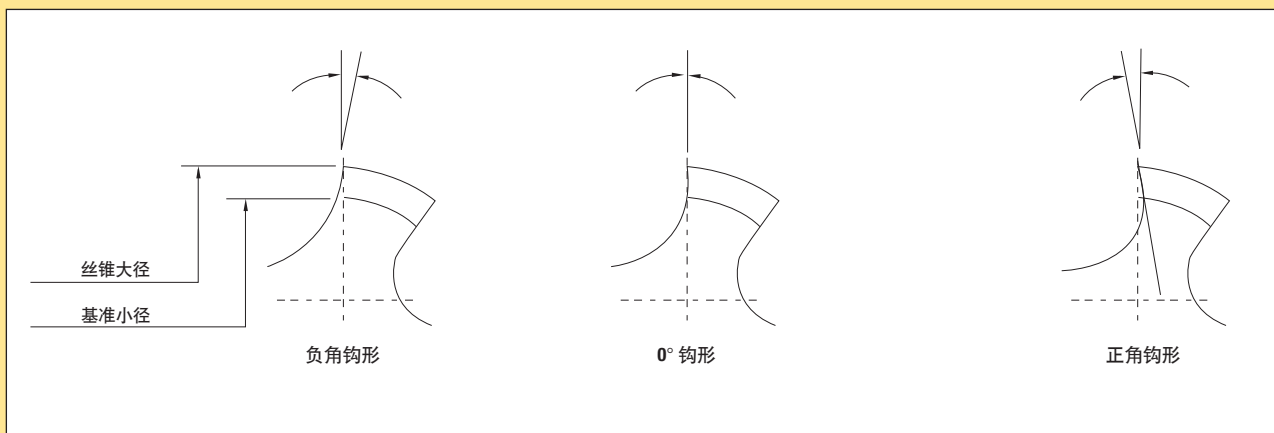
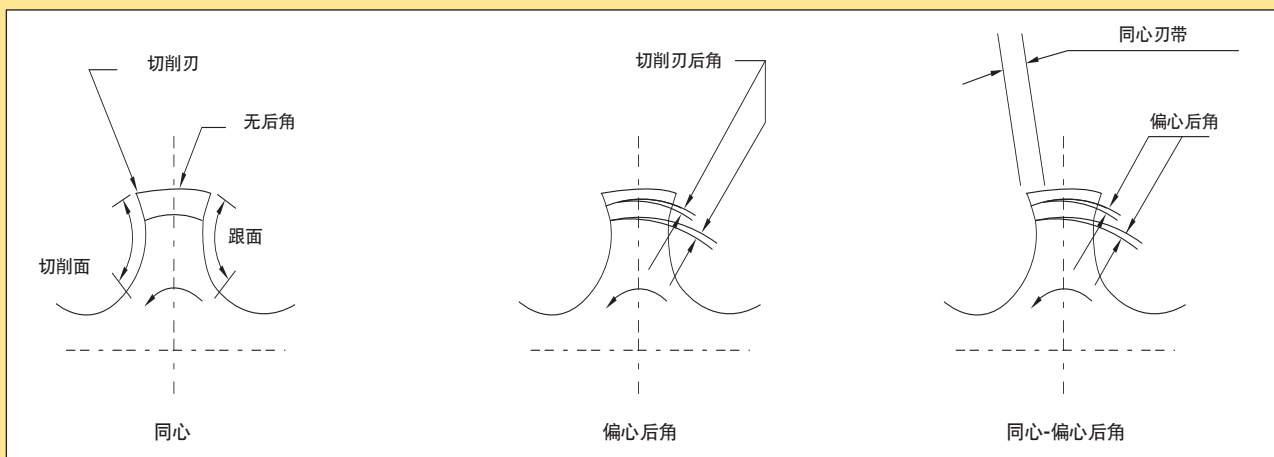
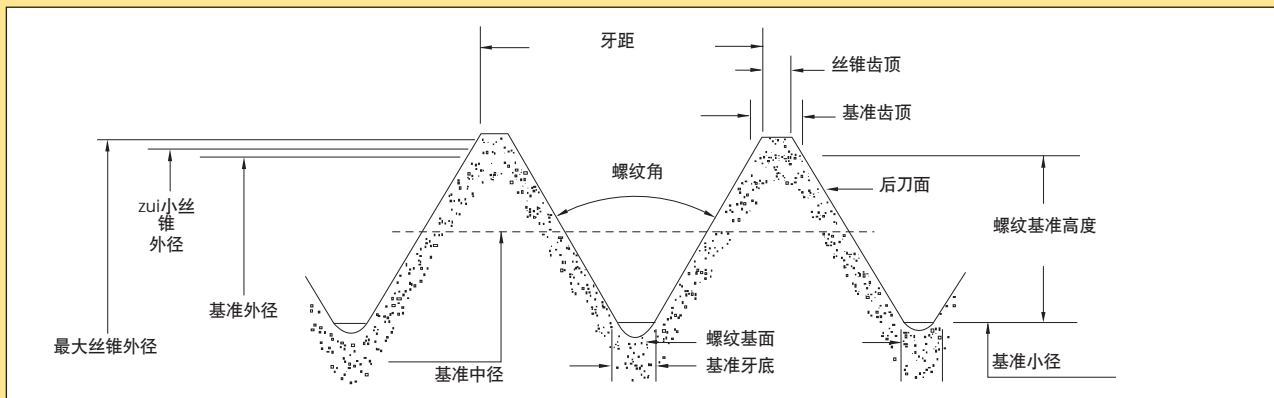

经过美国刀具协会 (USCTI) 批准印刷。肯纳金属公司发布 ©2014。保留所有权利。

■ 丝锥切削锥 • DIN 丝锥

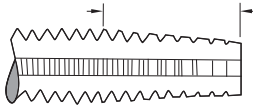
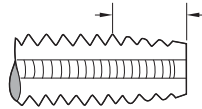
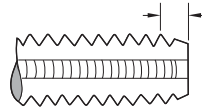
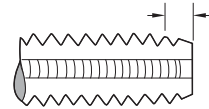
 TC 切削锥
 7-10 齿牙

 PC 切削锥
 3-5 齿牙

 切削锥
 2-2.5 齿

 FB 切削锥
 1-2 齿牙

手用丝锥切削锥

A 型 (6-8 齿牙)

A 型切削锥具有 zui 长的标准型斜面，便于初始加工操作。因为有较多的工作齿牙，因此只需较小的攻丝扭矩。

B/D 型 (3.5-5 齿牙)

常见的切削锥，适合通孔和盲孔的手用或机用加工。B 型适用于螺尖型丝锥，D 型适用于直槽及螺旋槽丝锥。这种类型的切削锥比 E 型或 C 型切削锥更加高效。

C 型 (2-2.5 齿)

这款短斜面切削锥可用于靠近盲孔底部的螺纹加工。这种类型的切削锥因为有较长的斜面以及更多的工作齿，因此比 E 型切削锥更加高效。

E 型 (1.5-2 齿牙)

在靠近盲孔底部的螺纹加工中，E 型切削锥是目前效率最低的产品。

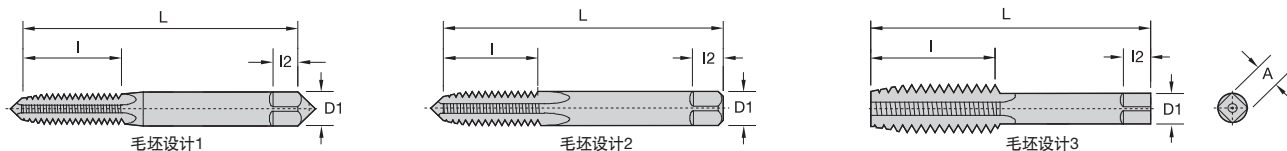

公称直径范围 (英寸)	机用螺钉尺寸编号 (英寸)	公称分数制直径 (英寸)	公称公制直径 (毫米 (英寸))	毛坯产品编号	总长度 L	螺纹长度 l	方头长度 l2	刀杆直径 D1	方头尺寸 A
.052-.065	0 (.0600)	—	M1.6 (.0630)	1	1.63	.31	.19	.1410	.110
.065-.078	1 (.0730)	—	M1.8 (.0709)	1	1.69	.38	.19	.1410	.110
.078-.091	2 (.0860)	—	M2 (0.787), M2.2 (.0866)	1	1.75	.44	.19	.1410	.110
.091-.104	3 (.0990)	—	M2.5 (.0984)	1	1.81	.50	.19	.1410	.110
.104-.117	4 (.1120)	—	—	1	1.88	.56	.19	.1410	.110
.117-.130	5 (.1250)	—	M3 (.1181)	1	1.94	.63	.19	.1410	.110
.130-.145	6 (.1380)	—	M3.5 (.1378)	1	2.00	.69	.19	.1410	.110
.145-.171	8 (.1640)	—	M4 (.1575)	1	2.13	.75	.25	.1680	.131
.171-.197	10 (.1900)	—	M4.5 (.1772), M5 (.1969)	1	2.38	.88	.25	.1940	.152
.197-.223	12 (.2160)	—	—	1	2.38	.94	.28	.2200	.165
.223-.260	—	1/4 (.2500)	M6 (.2362)	2	2.50	1.00	.31	.2550	.191
.260-.323	—	5/16 (.3125)	M7 (.2756), M8 (.3150)	2	2.72	1.13	.38	.3180	.238
.323-.395	—	3/8 (.3750)	M10 (.3937)	2	2.94	1.25	.44	.3810	.286
.395-.448	—	7/16 (.4375)	—	3	3.16	1.44	.41	.3230	.242
.448-.510	—	1/2 (.5000)	M12 (.4724)	3	3.38	1.66	.44	.3670	.275
.510-.573	—	9/16 (.5625)	M14 (.5512)	3	3.59	1.66	.50	.4290	.322
.573-.635	—	5/8 (.6250)	M16 (.6299)	3	3.81	1.81	.56	.4800	.360
.635-.709	—	11/16 (.6875)	M18 (.7087)	3	4.03	1.81	.63	.5420	.406
.709-.760	—	3/4 (.7500)	—	3	4.25	2.00	.69	.5900	.442
.760-.823	—	13/16 (.8125)	M20 (.7874)	3	4.47	2.00	.69	.6520	.489
.823-.885	—	7/8 (.8750)	M22 (.8661)	3	4.69	2.22	.75	.6970	.523
.885-.948	—	15/16 (.9375)	M24 (.9449)	3	4.91	2.22	.75	.7600	.570
.948-1.010	—	1 (1.0000)	M25 (.9843)	3	5.13	2.50	.81	.8000	.600
1.010-1.073	—	1-1/16 (1.0625)	M27 (1.0630)	3	5.13	2.50	.88	.8960	.672
1.073-1.135	—	1-1/8 (1.1250)	—	3	5.44	2.56	.88	.8960	.672
1.135-1.198	—	1-3/16 (1.1875)	M30 (1.1811)	3	5.44	2.56	1.00	1.0210	.766
1.198-1.260	—	1-1/4 (1.2500)	—	3	5.75	2.56	1.00	1.0210	.766
1.260-1.323	—	1-5/16 (1.3125)	M33 (1.2992)	3	5.75	2.56	1.06	1.1080	.831
1.323-1.385	—	1-3/8 (1.3750)	—	3	6.06	3.00	1.06	1.1080	.831
1.358-1.448	—	1-7/16 (1.4375)	M36 (1.4173)	3	6.06	3.00	1.13	1.2330	.925
1.448-1.510	—	1-1/2 (1.5000)	—	3	6.38	3.00	1.13	1.2330	.925
1.510-1.635	—	1-5/8 (1.6250)	M39 (1.5354)	3	6.69	3.19	1.13	1.3050	.979
1.635-1.760	—	1-3/4 (1.7500)	M42 (1.6535)	3	7.00	3.19	1.25	1.4300	1.072
1.760-1.885	—	1-7/8 (1.8750)	—	3	7.31	3.56	1.25	1.5190	1.139
1.885-2.010	—	2 (2.0000)	M48 (1.8898)	3	7.63	3.56	1.38	1.6440	1.233
2.010-2.135	—	2-1/8 (2.1250)	—	3	8.00	3.56	1.38	1.7690	1.327
2.135-2.260	—	2-1/4 (2.2500)	M56 (2.2047)	3	8.25	3.56	1.44	1.8940	1.420
2.260-2.385	—	2-3/8 (2.3750)	—	3	8.50	4.00	1.44	2.0190	1.514
2.385-2.510	—	2-1/2 (2.5000)	—	3	8.75	4.00	1.50	2.1000	1.575
2.510-2.635	—	2-5/8 (2.6250)	M64 (2.5197)	3	8.75	4.00	1.50	2.2250	1.669
2.635-2.760	—	2-3/4 (2.7500)	—	3	9.25	4.00	1.56	2.3500	1.762
2.760-2.885	—	2-7/8 (2.8750)	M72 (2.8346)	3	9.25	4.00	1.56	2.4750	1.856
2.885-3.010	—	3 (3.0000)	—	3	9.75	4.56	1.63	2.5430	1.907
3.010-3.135	—	3-1/8 (3.1250)	—	3	9.75	4.56	1.63	2.6680	2.001
3.135-3.260	—	3-1/4 (3.2500)	M80 (3.1496)	3	10.00	4.56	1.75	2.7930	2.095
3.260-3.385	—	3-3/8 (3.3750)	—	3	10.00	4.56	1.75	2.8830	2.162
3.385-3.510	—	3-1/2 (3.5000)	—	3	10.25	4.94	2.00	3.0080	2.256
3.510-3.635	—	3-5/8 (3.6250)	M90 (3.5433)	3	10.25	4.94	2.00	3.1330	2.350
3.635-3.760	—	3-3/4 (3.7500)	—	3	10.50	5.31	2.13	3.2170	2.413
3.760-3.885	—	3-7/8 (3.8750)	—	3	10.50	5.31	2.13	3.3420	2.506
3.885-4.010	—	4 (4.0000)	M100 (3.9370)	3	10.75	5.31	2.25	3.4670	2.600

经过美国刀具协会 (USCTI) 批准印刷。肯纳金属公司发布 ©2014。保留所有权利。

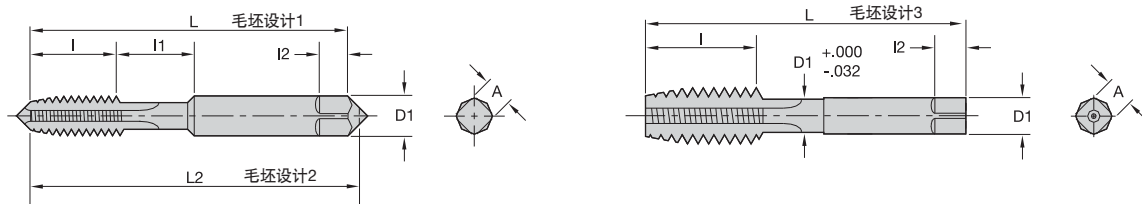

■ 基本尺寸

丝锥尺寸 - 英寸

公称直径范围 (英寸)	机用螺钉规格 (英寸)	公称分数制直径 (英寸)	公制产品直径毫米 (英寸)	毛胚设计产品编号	总长度 L	螺纹长度 l	颈部长度 l1	方头长度 l2	刀杆直径 D1	方头尺寸 A
.104 .117	4 (.1120)	—	—	1	1.88	.31	.25	.19	.1410	.110
.117 .130	5 (.1250)	—	M3 (.1181)	1	1.94	.31	.31	.19	.1410	.110
.130 .145	6 (.1380)	—	M3.5 (.1378)	1	2.00	.38	.31	.19	.1410	.110
.145 .171	8 (.1640)	—	M4 (.1575)	1	2.13	.38	.38	.25	.1680	.131
.171 .197	10 (.1900)	—	M4.5 (.1772)	1	2.38	.50	.38	.25	.1940	.152
— —	— —	—	M5 (.1969)	—	—	—	—	—	—	—
.197 .223	12 (.2160)	—	—	1	2.38	.50	.44	.28	.2200	.165
.223 .260	—	1/4 (.2500)	M6 (.2362)	2	2.50	.63	.38	.31	.2550	.191
.260 .323	—	5/16 (.3125)	M7, M8 (.2756), (.3150)	2	2.72	.69	.44	.38	.3180	.238
.323 .395	—	3/8 (.3750)	M10 (.3937)	2	2.94	.75	.50	.44	.3810	.286
.395 .448	—	7/16 (.4375)	—	3	3.16	.88	—	.41	.3230	.242
.448 .510	—	1/2 (.5000)	M12 (.4724)	3	3.38	.94	—	.44	.3670	.275
.510 .573	—	9/16 (.5625)	M14 (.5541)	3	3.59	1.00	—	.50	.4290	.322
.573 .635	—	5/8 (.6250)	M16 (.6299)	3	3.81	1.09	—	.56	.4800	.360
.635 .709	—	11/16 (.6875)	M18 (.7087)	3	4.03	1.09	—	.63	.5420	.406
.709 .760	—	3/4 (.7500)	—	3	4.25	1.22	—	.69	.5900	.442
.760 .823	—	13/16 (.8125)	M20 (.7874)	3	4.47	1.22	—	.69	.6520	.489
.823 .885	—	7/8 (.8750)	M22 (.8661)	3	4.69	1.34	—	.75	.3670	.523
.885 .948	—	15/16 (.9375)	M24 (.9449)	3	4.91	1.34	—	.75	.7600	.570
.948 1.010	—	1 (1.0000)	M25 (.9843)	3	5.13	1.50	—	.81	.8000	.600

经过美国刀具协会 (USCTI) 批准印刷。
肯纳金属公司发布 ©2014。保留所有权利。

注: 螺纹长度根据12螺牙UNC螺纹系列产品计算。螺纹长度“l”为zui小值, 没有公差规定
在螺纹长度“l”与颈部长度“l1”相加后, 总长度不得小于USCTI 302表中的zui小螺纹长度值“l”
。除非另有注明, 公差值符合USCTI 302表的标准。偏心度公差请参看USCTI 317表。
提供的302表仅供参考。肯纳金属丝锥尺寸可能会有不同。

■ 公差等级

几何尺寸	公称直径范围 (英寸)	方向	公差 (英寸)
总长度 - L	.0520-1.0100	加或减	.031
	1.0100-4.0100	加或减	.063
螺纹长度 - l	.0520-.2230	加或减	.047
	.2230-.5100	加或减	.063
方头长度 - l2	.5100-1.5100	加或减	.094
	1.5100-4.0100	加或减	.125
刀杆直径 - d1	.0520-.2230	减	.0015
	.2230-.6350	减	.0015
方头尺寸 - a	.6350-1.0100	减	.0020
	1.0100-1.5100	减	.0020
方头尺寸 - a	1.5100-2.0100	减	.0030
	2.0100-4.0100	减	.0030
方头尺寸 - a	.0520-.5100	减	.004
	.5100-1.0100	减	.006
方头尺寸 - a	1.0100-2.0100	减	.008
	2.0100-4.0100	减	.010

经过美国刀具协会 (USCTI) 批准印刷。
肯纳金属公司发布 ©2014。保留所有权利。

■ 特殊丝锥

除非另有标定: 包括直径为1.010-1.510英寸的特殊丝锥产品, 每英寸螺纹数为14或以上, 螺距为1.75毫米或更小; 直径超过1.510英寸, 每英寸螺纹数为10或以上, 螺距为2.5毫米或更小; 这些特殊丝锥产品的尺寸符合USCTI 303表中基本尺寸的规定。特殊丝锥螺纹限度由统一英制螺纹USCTI 331表中的公式, 以及公制M型螺纹USCTI 341表中的公式确定。

注: 规格为.395" 或更小的丝锥在螺纹末端处有一个尖端 (切削锥上可以去除)。规格为.125" 或更小的丝锥在刀杆末端处有一个尖端。规格为.224-.395" 的丝锥在刀杆末端处有一个局部短锥型尖端 (短锥长度约为刀杆直径的1/4。规格超过.395" 的丝锥在螺纹末端处和刀杆末端处均有一个尖端。

了解标准型螺纹限度及统一英制螺纹公差, 请参看USCTI 327表; 了解公制螺纹请参看USCTI 337表。

丝锥几何尺寸中的偏心度公差请参看USCTI 317表。



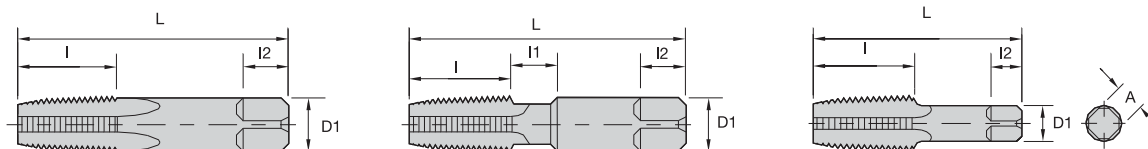

■ 基本尺寸

公称尺寸 (英寸)	尺寸 (英寸)					
	总长度 L	螺纹长度 l	方头长度 l2	刀杆直径 D1	方头尺寸 A	可选刀颈长度 l1
1/16	2.13	.69	.38	.3125	.234	.375
1/8	2.13	.75	.38	.3125	.234	-
1/8	2.13	.75	.38	.4375	.328	.375
1/4	2.44	1.06	.44	.5625	.421	.375
3/8	2.56	1.06	.50	.7000	.531	.375
1/2	3.13	1.38	.63	.6875	.515	-
3/4	3.25	1.38	.69	.9063	.679	-
1	3.75	1.75	.81	1.1250	.843	-
1-1/4	4.00	1.75	.94	1.3125	.984	-
1-1/2	4.25	1.75	1.00	1.5000	1.125	-
2	4.25	1.75	1.13	1.8750	1.406	-
2-1/2	5.50	2.56	1.25	2.2500	1.687	-
3	6.00	2.63	1.38	2.6250	1.968	-
3-1/2	6.50	2.69	1.50	2.8125	2.108	-
4	6.75	2.75	1.56	3.0000	2.250	-

■ 公差等级

几何尺寸	范围	方向	公差等级
总长度 - L	1/16-3/4 inc.	加/减	.031
	1-4 inc.	加/减	.063
螺纹长度 - l	1/16-3/4 inc.	加/减	.063
	1-1-1/4 inc.	加/减	.094
方头长度 - l2	1-1/2-4	加/减	.125
	1/16-3/4 inc.	加/减	.031
刀杆直径 - d1	1-4 inc.	加/减	.063
	1/4-1 inc.	减	.0020
方头尺寸 - a	1-1/4-4 inc.	减	.0030
	1/16-1/8	减	.004
	1/4-3/4 inc.	减	.006
	1-4 inc.	减	.008

经过美国刀具协会 (USCTI) 批准印刷。肯纳金属公司发布 © 2014。保留所有权利。

攻丝



美国标准锥形管螺纹牙型 (NPT)
航空国家标准锥形管螺纹牙型 (ANPT)
干式密封美国国家标准锥形管螺纹牙型 (NPTF)

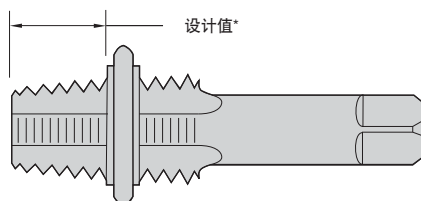

每英尺斜度限度

公称尺寸 (英寸)	每英寸螺纹数	悬伸量* (英寸)	悬伸量公差 +/-	最小值	最大值	长度L1	螺孔钻尺寸** NPT, ANPT, NPTF
1/16	27	.312	.063	.719	.781	.160	C
1/8	27	.312	.063	.719	.781	.1615	Q
1/4	18	.459	.063	.719	.781	.2278	7/16
3/8	18	.454	.063	.719	.781	.240	9/16
1/2	14	.579	.063	.719	.781	.320	45/64
3/4	14	.565	.063	.719	.781	.339	29/32
1	11-1/2	.678	.094	.719	.781	.400	1-9/64
1-1/4	11-1/2	.686	.094	.719	.781	.420	1-31/64
1-1/2	11-1/2	.699	.094	.719	.781	.420	1-23/32
2	11-1/2	.667	.094	.719	.781	.436	2-3/16
2-1/2	8	.925	.094	.734	.781	.682	2-39/64
3	8	.925	.094	.734	.781	.766	3-15/64
3-1/2	8	.938	.125	.734	.781	.821	—
4	8	.950	.125	.734	.781	.844	—

* 丝锥小端悬伸量是从 L1 锥形螺纹环规处开始计算。

** 推荐尺寸丝锥可以在未对孔进行较削情况下直接攻丝，但仅在全螺纹长度约为 L1 长度的情况下。经过美国刀具协会 (USCTI) 批准印刷。肯纳金属公司发布 ©2014。保留所有权利。

■ 管用丝锥

通用型管用丝锥适合对多种材料进行螺纹加工，包括铁质材料和非铁材料。

磨光螺纹管用丝锥在美国标准管用螺纹牙型 (NPT) 以及美国标准干式密封管用螺纹牙型 (NPTF) 中为标准型产品。NPT 螺纹需要使用密封材料，如 Teflon® 密封带或管复合材料。干密封丝锥用于水管连接件，可以在不使用密封材料的情况下形成紧密联接。

管用丝锥的公称尺寸是用于攻丝的管径尺寸，而不是丝锥的实际尺寸。螺纹的每英尺斜度为 3/4 英寸。

所有管用丝锥经过 2-1/2-3-1/2 螺纹倒角精加工处理。

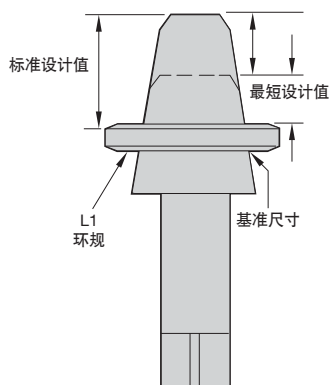

短悬伸管用丝锥的悬伸量比标准丝锥悬伸量小，用于对攻丝深度受到限制的锥形管攻丝加工。

特殊短悬伸锥形管用丝锥可以精加工为美国国家标准锥形管螺纹 (ANPT)，或是干密封美国国家标准锥形管螺纹 (NPTF、PTF-SAE 短型，或 PTF-SPL 超短型)。

了解短悬伸管用丝锥信息，以及加工 NPT、NPTF 和 ANPT 内管螺纹时的孔口加工前准备工作，请查看肯纳金属技术信息公告。

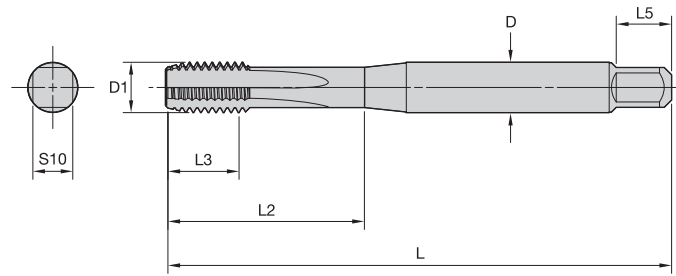

■ DIN 371

D1	螺距	D	L	L3*	L2	L5	S10
M3	0,5	3,5	56	11	18	6	2,7
M3,5	0,6	4	56	12	20	6	3
M4	0,7	4,5	63	13	21	6	3,4
M4,5	0,75	6	70	16	25	8	4,9
M5	0,8	6	70	16	25	8	4,9
M6	1	6	80	19	30	8	4,9
M7	1	7	80	19	30	8	5,5
M8	0,75	8	80	18	30	9	6,2
M8	1,25	8	90	22	35	9	6,2
M9	0,75	9	80	18	30	10	7
M9	1,25	9	90	22	35	10	7
M10	1	10	90	20	35	11	8
M10	1,5	10	100	24	39	11	8

* 最大值

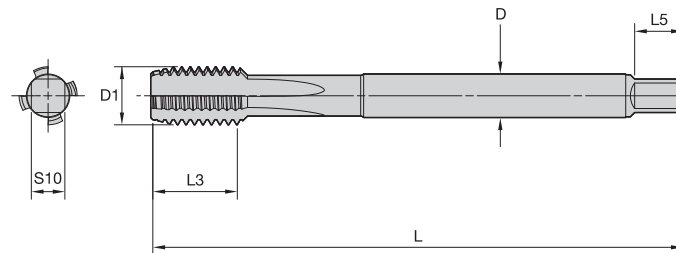

■ DIN 376

D1	螺距	D	L	L3*	L5	S10
M8	1,25	6	90	22	8	4,9
M9	1,25	7	90	22	8	5,5
M10	1,5	7	100	24	8	5,5
M11	1,5	8	100	24	9	6,2
M12	1,75	9	110	28	10	7
M14	2	11	110	30	12	9
M16	2	12	110	32	12	9
M18	2,5	14	125	34	14	11
M20	2,5	16	140	34	15	12
M22	2,5	18	140	34	17	14,5
M24	3	18	160	38	17	14,5
M27	3	20	160	38	19	16
M30	3,5	22	180	45	21	18
M33	3,5	25	180	50	23	20
M36	4	28	200	56	25	22
M39	4	32	200	60	27	24
M42	4,5	32	200	60	27	24
M45	4,5	36	220	65	32	29

* 最大值

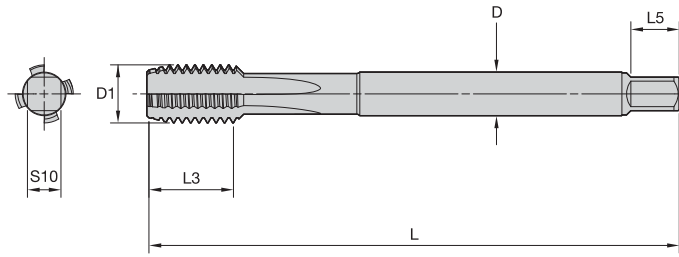

■ DIN 374

螺距

D1	最小值	最大值	D	L	L3*	L5	S10
M8	0,2	0,75	6	80	18	8	4,9
M8	—	1	6	90	22	8	4,9
M9	0,2	0,75	7	80	18	8	5,5
M9	—	1	7	90	22	8	5,5
M10	0,2	1	7	90	20	8	5,5
M10	—	1,25	7	100	24	8	5,5
M11	0,35	1	8	90	20	9	6,2
M12	0,35	1,5	9	100	22	10	7
M14	0,35	1,5	11	100	22	12	9
M16	0,35	1,5	12	100	22	12	9
M16	—	2	12	110	32	12	9
M18	0,35	1,5	14	110	25	14	11
M18	—	2	14	125	34	14	11
M20	0,35	1,5	16	125	25	15	12
M20	—	2	16	140	34	15	12
M22	0,35	1,5	18	125	25	17	14,5
M22	—	2	18	140	34	17	14,5
M24	0,35	2	18	140	28	17	14,5
M27	0,35	2	20	140	28	19	16
M30	0,35	2	22	150	28	21	18
M30	—	3	22	180	45	21	18

* 最大值

攻丝

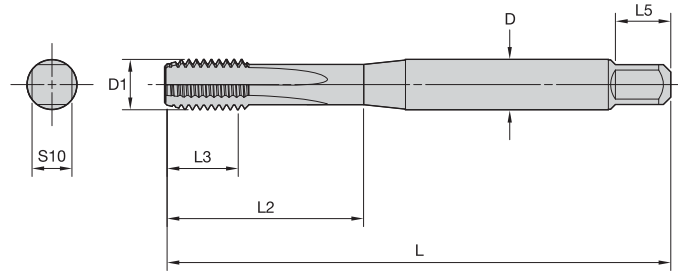

■ JIS 2型公制粗牙

公制尺寸

D1	螺距	D	L	L3	L2	L5	S10
M3	0,5	4	46	11	19	6	3,2
M3,5	0,6	4	48	13	20	6	3,2
M4	0,7	5	52	13	21	7	4
M4,5	0,75	5	55	13	21	7	4
M5	0,8	5,5	60	16	24	7	4,5
M6	1	6	62	19	29	7	4,5

攻丝

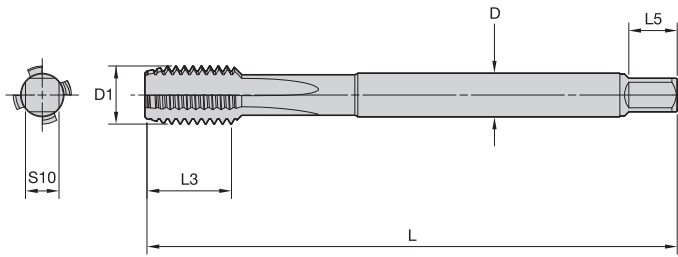

■ JIS 3型公制粗牙

公制尺寸

D1	螺距	D	L	L3	L5	S10
M8	1,25	6,2	70	22	8	5
M9	1,25	7	72	22	8	5,5
M10	1,5	7	75	24	8	5,5
M11	1,5	8	80	25	9	6
M12	1,75	8,5	82	29	9	6,5
M14	2	10,5	88	30	11	8
M16	2	12,5	95	32	13	10
M18	2,5	14	100	37	14	11
M20	2,5	15	105	37	15	12
M22	2,5	17	115	38	16	13
M24	3	19	120	45	18	15

■ 螺纹加工 • UNC, UNF, 和 8牙

丝锥尺寸	每英寸牙数			65% 螺纹嵌合率						70% 螺纹嵌合率						75% 螺纹嵌合率					
				公制			英制			公制			英制			公制			英制		
	UNC	UNF	8牙	最小 钻径	理论值	最大 钻径	最小 钻径	理论值	最大 钻径	最小 钻径	理论值	最大 钻径	最小 钻径	理论值	最大 钻径	最小 钻径	理论值	最大 钻径	最小 钻径	理论值	最大 钻径
#0	-	80	-	1.20	1.26	1.30	0.0472	0.0494	0.0512	1.20	1.24	1.30	0.0472	0.0486	0.0512	1.20	1.21	1.30	0.0472	0.0478	0.0512
#1	64	-	-	1.50	1.52	1.60	0.0591	0.0598	0.0630	1.40	1.49	1.50	0.0551	0.0588	0.0591	1.40	1.47	1.50	0.0551	0.0578	0.0591
	-	72	-	1.50	1.56	1.60	0.0591	0.0613	0.0630	1.50	1.53	1.60	0.0591	0.0604	0.0630	1.50	1.51	1.60	0.0591	0.0595	0.0630
#2	56	-	-	1.80	1.80	1.80	0.0709	0.0709	0.0709	1.70	1.77	1.80	0.0669	0.0698	0.0709	1.70	1.74	1.80	0.0669	0.0686	0.0709
	-	64	-	1.80	1.85	1.90	0.0709	0.0728	0.0748	1.80	1.82	1.90	0.0709	0.0718	0.0748	1.80	1.80	1.80	0.0669	0.0708	0.0709
#3	48	-	-	2.00	2.07	2.10	0.0787	0.0814	0.0827	2.00	2.03	2.10	0.0787	0.0801	0.0827	2.00	2.00	2.00	0.0787	0.0787	0.0787
	-	56	-	2.10	2.13	2.20	0.0827	0.0839	0.0866	2.10	2.10	2.10	0.0827	0.0828	0.0866	2.00	2.07	2.10	0.0787	0.0816	0.0827
#4	40	-	-	2.30	2.31	2.38	0.0906	0.0909	0.0938	2.20	2.27	2.30	0.0866	0.0893	0.0906	2.20	2.23	2.30	0.0866	0.0876	0.0906
	-	48	-	2.40	2.40	2.40	0.0938	0.0944	0.0945	2.30	2.36	2.38	0.0906	0.0931	0.0938	2.30	2.33	2.38	0.0906	0.0917	0.0938
#5	40	-	-	2.64	2.64	2.64	0.1024	0.1039	0.1040	2.60	2.60	2.60	0.1015	0.1023	0.1024	2.50	2.56	2.58	0.0984	0.1006	0.1015
	-	44	-	2.64	2.69	2.70	0.1040	0.1058	0.1063	2.64	2.65	2.70	0.1040	0.1043	0.1063	2.60	2.61	2.64	0.1024	0.1029	0.1040
#6	32	-	-	2.82	2.83	2.87	0.1100	0.1116	0.1130	2.78	2.78	2.78	0.1094	0.1096	0.1102	2.71	2.73	2.78	0.1065	0.1076	0.1094
	-	40	-	2.95	2.97	3.00	0.1160	0.1169	0.1181	2.90	2.93	2.95	0.1142	0.1153	0.1160	2.87	2.89	2.90	0.1130	0.1136	0.1142
#8	32	-	-	3.50	3.50	3.50	0.1360	0.1376	0.1378	3.40	3.44	3.46	0.1339	0.1356	0.1360	3.30	3.39	3.40	0.1299	0.1336	0.1339
	-	36	-	3.57	3.57	3.57	0.1378	0.1405	0.1406	3.50	3.52	3.57	0.1378	0.1387	0.1406	3.46	3.48	3.50	0.1360	0.1369	0.1378
#10	24	-	-	3.90	3.93	3.97	0.1535	0.1548	0.1563	3.80	3.86	3.90	0.1496	0.1521	0.1535	3.73	3.79	3.80	0.1470	0.1494	0.1496
	-	32	-	4.10	4.16	4.20	0.1614	0.1636	0.1654	4.10	4.10	4.10	0.1614	0.1616	0.1654	4.04	4.05	4.09	0.1590	0.1596	0.1610
#12	24	-	-	4.50	4.59	4.60	0.1772	0.1808	0.1811	4.50	4.52	4.60	0.1772	0.1781	0.1811	4.40	4.46	4.50	0.1732	0.1754	0.1772
	-	28	-	4.70	4.72	4.76	0.1850	0.1858	0.1875	4.62	4.66	4.70	0.1820	0.1835	0.1850	4.60	4.60	4.60	0.1811	0.1812	0.1820
1/4	20	-	-	5.20	5.28	5.30	0.2047	0.2078	0.2087	5.20	5.20	5.20	0.2031	0.2045	0.2047	5.11	5.11	5.11	0.2010	0.2013	0.2031
	-	28	-	5.56	5.58	5.60	0.2188	0.2198	0.2205	5.50	5.53	5.56	0.2165	0.2175	0.2188	5.41	5.47	5.50	0.2130	0.2152	0.2165
5/16	18	-	-	6.75	6.75	6.75	0.2656	0.2656	0.2656	6.63	6.65	6.70	0.2610	0.2620	0.2638	6.53	6.56	6.60	0.2570	0.2584	0.2598
	-	24	-	7.00	7.04	7.10	0.2756	0.2773	0.2795	6.90	6.98	7.00	0.2717	0.2746	0.2756	6.90	6.91	7.00	0.2717	0.2719	0.2756
3/8	16	-	-	8.10	8.18	8.20	0.3189	0.3222	0.3228	8.00	8.08	8.10	0.3150	0.3182	0.3189	7.94	7.98	8.00	0.3125	0.3141	0.3150
	-	24	-	8.60	8.63	8.70	0.3386	0.3398	0.3425	8.50	8.56	8.60	0.3346	0.3371	0.3386	8.43	8.49	8.50	0.3320	0.3344	0.3346
7/16	14	-	-	9.53	9.58	9.60	0.3750	0.3772	0.3780	9.40	9.46	9.50	0.3701	0.3726	0.3740	9.30	9.34	9.35	0.3661	0.3679	0.3680
	-	20	-	10.00	10.04	10.10	0.3937	0.3953	0.3976	9.92	9.96	10.00	0.3906	0.3920	0.3937	9.80	9.88	9.90	0.3858	0.3888	0.3898
1/2	13	-	-	11.00	11.05	11.10	0.4331	0.4351	0.4370	10.90	10.92	11.00	0.4291	0.4301	0.4331	10.80	10.80	10.80	0.4219	0.4251	0.4252
	-	20	-	11.60	11.63	11.70	0.4528	0.4578	0.4606	11.51	11.55	11.60	0.4528	0.4545	0.4606	11.40	11.46	11.50	0.4488	0.4513	0.4528
9/16	12	-	-	12.50	12.50	12.50	0.4921	0.4921	0.4921	12.30	12.36	12.40	0.4844	0.4867	0.4882	12.20	12.23	12.30	0.4803	0.4813	0.4843
	-	18	-	13.10	13.10	13.10	0.5118	0.5156	0.5157	13.00	13.00	13.00	0.5118	0.5120	0.5157	12.80	12.91	13.00	0.5039	0.5084	0.5118
5/8	11	-	-	13.80	13.93	14.00	0.5433	0.5482	0.5512	13.50	13.78	13.80	0.5315	0.5423	0.5433	13.50	13.63	13.80	0.5315	0.5364	0.5433
	-	18	-	14.50	14.68	15.00	0.5709	0.5781	0.5906	14.50	14.59	15.00	0.5709	0.5745	0.5906	14.50	14.50	14.50	0.5709	0.5709	0.5709
3/4	10	-	-	16.50	16.91	17.00	0.6496	0.6656	0.6693	16.50	16.74	17.00	0.6496	0.6591	0.6693	16.50	16.58	17.00	0.6496	0.6526	0.6560
	-	16	-	17.50	17.71	18.00	0.6890	0.6972	0.7087	17.50	17.61	18.00	0.6890	0.6932	0.7087	17.50	17.50	17.50	0.6890	0.6891	0.6969
7/8	9	-	-	19.50	19.84	20.00	0.7677	0.7812	0.7874	19.50	19.66	20.00	0.7677	0.7740	0.7874	19.00	19.48	19.50	0.7660	0.7668	0.7677
	-	14	-	20.50	20.69	21.00	0.8071	0.8147	0.8268	20.50	20.58	21.00	0.8071	0.8101	0.8268	20.00	20.46	20.50	0.8012	0.8054	0.8071
1	8	-	-	22.50	22.72	22.77	0.8858	0.8945	0.8965	22.50	22.51	22.77	0.8858	0.8863	0.8965	22.23	22.31	22.44	0.8750	0.8782	0.8840
	-	12	-	23.50	23.61	23.81	0.9252	0.9296	0.9375	23.42	23.48	23.50	0.9220	0.9242	0.9252	23.30	23.34	23.42	0.9173	0.9188	0.9220
1-1/8	7	-	-	25.50	25.51	25.60	1.0039	1.0044	1.0080	25.07	25.28	25.40	0.9870	0.9951	1.0000	25.00	25.04	25.07	0.9843	0.9858	0.9870
	-	12	-	26.70	26.79	27.00	1.0512	1.0546	1.0610	26.59	26.65	26.70	1.0470	1.0492	1.0512	26.50	26.51	26.59	1.0433	1.0438	1.0470
1-1/4	-	-	8	25.81	25.89	26.00	1.0160	1.0195	1.0236	25.67	25.69	25.81	1.0110	1.0113	1.0160	25.40	25.48	25.50	1.0000	1.0032	1.0039
	7	-	-	28.58	28.69	29.00	1.1250	1.1294	1.1417	28.18	28.45	28.50	1.1090	1.1201	1.1220	28.18	28.21	28.50	1.1090	1.1108	1.1220
	-	12	-	29.77	29.96	30.00	1.1720	1.1796	1.1811	29.77	29.83	30.00	1.1720	1.1742	1.1811	29.50	29.69	29.73	1.1614	1.1688	1.1720
-	-	8	29.00	29.07	29.50	1.1417	1.1445	1.1560	28.58	28.86	29.00	1.1250	1.1363	1.1417	28.58	28.66	29.00	1.1250	1.1282	1.1417	

(续)

(螺纹加工 • UNC, UNF, 和 8牙 – 续)

丝锥尺寸	每英寸牙数			65% 螺纹嵌合率						70% 螺纹嵌合率						75% 螺纹嵌合率					
				公制			英制			公制			英制			公制			英制		
	UNC	UNF	8牙	最小 钻径	理论值	最大 钻径	最小 钻径	理论值	最大 钻径	最小 钻径	理论值	最大 钻径	最小 钻径	理论值	最大 钻径	最小 钻径	理论值	最大 钻径	最小 钻径	理论值	最大 钻径
1-3/8	6	-	-	31.00	31.35	31.50	1.2200	1.2343	1.2402	31.00	31.08	31.50	1.2200	1.2235	1.2402	30.56	30.80	30.96	1.2030	1.2126	1.2190
	-	12	-	33.00	33.14	33.34	1.2992	1.3046	1.3130	33.00	33.00	33.00	1.2992	1.2992	1.2992	32.54	32.86	32.94	1.2810	1.2938	1.2970
	-	-	8	32.00	32.24	32.50	1.2598	1.2695	1.2795	32.00	32.04	32.50	1.2598	1.2613	1.2795	31.75	31.83	32.00	1.2500	1.2532	1.2598
1-1/2	6	-	-	34.50	34.53	34.93	1.3583	1.3593	1.3750	34.13	34.25	34.50	1.3440	1.3485	1.3583	33.73	33.98	34.00	1.3280	1.3376	1.3386
	-	12	-	36.12	36.31	36.50	1.4220	1.4296	1.4375	36.12	36.18	36.50	1.4220	1.4242	1.4375	36.00	36.04	36.12	1.4173	1.4188	1.4220
	-	-	8	35.00	35.42	35.50	1.3780	1.3945	1.3976	35.00	35.21	35.50	1.3780	1.3863	1.3976	35.00	35.01	35.50	1.3780	1.3782	1.3976
1-5/8	-	-	8	38.50	38.59	39.00	1.5157	1.5195	1.5354	38.10	38.39	38.46	1.5000	1.5113	1.5140	38.10	38.18	38.46	1.5000	1.5032	1.5140
1-3/4	5	-	-	40.00	40.16	41.00	1.5750	1.5811	1.6140	39.50	39.83	40.00	1.5551	1.5681	1.5748	39.50	39.50	39.50	1.5551	1.5552	1.5748
	-	-	8	41.00	41.77	42.00	1.6140	1.6445	1.6540	41.00	41.56	42.00	1.6140	1.6363	1.6540	41.00	41.36	42.00	1.6140	1.6282	1.6540
1-7/8	-	-	8	44.00	44.94	45.00	1.7320	1.7695	1.7720	44.00	44.74	45.00	1.7320	1.7613	1.7720	44.00	44.53	45.00	1.7320	1.7532	1.7720
2	4 1/2	-	-	46.00	46.03	47.00	1.8110	1.8124	1.8500	45.00	45.67	46.00	1.7720	1.7979	1.8110	45.00	45.30	46.00	1.7720	1.7835	1.8110
	-	-	8	48.00	48.12	49.00	1.8900	1.8945	1.9290	47.00	47.91	48.00	1.8500	1.8863	1.8900	47.00	47.71	48.00	1.8500	1.8782	1.8900
2-1/4	4 1/2	-	-	52.00	52.38	53.00	2.0470	2.0624	2.0870	52.00	52.02	53.00	2.0470	2.0479	2.0870	51.00	51.65	52.00	2.0080	2.0335	2.0470
	-	-	8	54.00	54.47	55.00	2.1260	2.1445	2.1650	54.00	54.26	55.00	2.1260	2.1363	2.1650	54.00	54.06	55.00	2.1260	2.1282	2.1650
2-1/2	4	-	-	58.00	58.14	59.00	2.2840	2.2889	2.3230	57.00	57.73	58.00	2.2440	2.2727	2.2840	57.00	57.31	58.00	2.2440	2.2564	2.2840
	-	-	8	60.00	60.82	61.00	2.3620	2.3945	2.4020	60.00	60.61	61.00	2.3620	2.3863	2.4020	60.00	60.41	61.00	2.3620	2.3782	2.4020

攻丝

螺纹加工 • M和MF

■ 螺纹加工 • M和MF

丝锥尺寸	螺距		65% 螺纹嵌合率						70% 螺纹嵌合率						75% 螺纹嵌合率					
			公制			英制			公制			英制			公制			英制		
	M	MF	最小 钻径	理论值	最大 钻径	最小 钻径	理论值	最大 钻径	最小 钻径	理论值	最大 钻径	最小 钻径	理论值	最大 钻径	最小 钻径	理论值	最大 钻径	最小 钻径	理论值	最大 钻径
M1.6	0.35	-	1.20	1.30	1.30	0.0512	0.0512	0.0512	1.20	1.28	1.30	0.0472	0.0504	0.0512	1.20	1.26	1.30	0.0472	0.0496	0.0512
M1.7	0.35	-	1.40	1.40	1.40	0.0551	0.0551	0.0551	1.32	1.38	1.40	0.0520	0.0543	0.0550	1.32	1.36	1.40	0.0520	0.0535	0.0550
M1.8	0.35	-	1.50	1.50	1.50	0.0591	0.0591	0.0591	1.40	1.48	1.50	0.0551	0.0583	0.0591	1.40	1.46	1.50	0.0551	0.0575	0.0591
M2	0.4	-	1.60	1.66	1.70	0.0630	0.0654	0.0669	1.60	1.64	1.70	0.0630	0.0646	0.0669	1.60	1.61	1.70	0.0630	0.0634	0.0669
M2.2	0.45	-	1.80	1.82	1.90	0.0709	0.0717	0.0748	1.70	1.79	1.80	0.0669	0.0705	0.0709	1.70	1.76	1.80	0.0669	0.0693	0.0709
M2.5	0.45	-	2.10	2.12	2.20	0.0827	0.0835	0.0866	2.00	2.09	2.10	0.0787	0.0823	0.0827	2.00	2.06	2.10	0.0787	0.0811	0.0827
M2.6	0.45	-	2.20	2.22	2.30	0.0866	0.0874	0.0906	2.10	2.19	2.20	0.0827	0.0862	0.0866	2.10	2.16	2.20	0.0827	0.0850	0.0866
M3	0.5	-	2.58	2.58	2.58	0.1015	0.1016	0.1024	2.50	2.55	2.58	0.0984	0.1004	0.1015	2.50	2.51	2.58	0.0984	0.0988	0.1015
	-	0.35	2.70	2.70	2.70	0.1063	0.1063	0.1063	2.64	2.68	2.70	0.1040	0.1055	0.1063	2.64	2.66	2.70	0.1040	0.1047	0.1063
M3.5	0.6	-	2.95	2.99	3.00	0.1160	0.1177	0.1181	2.95	2.95	3.00	0.1160	0.1161	0.1181	2.90	2.92	2.95	0.1142	0.1150	0.1160
M4	0.7	-	3.40	3.41	3.46	0.1339	0.1343	0.1360	3.30	3.36	3.40	0.1299	0.1323	0.1339	3.30	3.32	3.40	0.1299	0.1307	0.1339
	-	0.5	3.57	3.58	3.60	0.1406	0.1409	0.1417	3.50	3.54	3.57	0.1378	0.1394	0.1406	3.50	3.51	3.57	0.1378	0.1382	0.1406
M4.5	0.75	-	3.80	3.87	3.90	0.1496	0.1524	0.1535	3.80	3.82	3.90	0.1496	0.1504	0.1535	3.73	3.77	3.80	0.1470	0.1484	0.1496
M5	0.8	-	4.30	4.32	4.37	0.1693	0.1701	0.1719	4.22	4.27	4.30	0.1660	0.1681	0.1693	4.22	4.22	4.30	0.1660	0.1661	0.1693
	-	0.5	4.50	4.58	4.60	0.1772	0.1803	0.1811	4.50	4.54	4.60	0.1772	0.1787	0.1811	4.50	4.51	4.60	0.1772	0.1776	0.1811
M6	1	-	5.16	5.16	5.16	0.2031	0.2031	0.2031	5.00	5.09	5.10	0.1969	0.2004	0.2008	5.00	5.03	5.10	0.1969	0.1980	0.2008
	-	0.75	5.30	5.37	5.40	0.2087	0.2114	0.2126	5.30	5.32	5.40	0.2087	0.2094	0.2126	5.20	5.27	5.30	0.2047	0.2075	0.2087
M7	1	-	6.10	6.16	6.20	0.2402	0.2425	0.2441	6.00	6.09	6.10	0.2362	0.2398	0.2402	6.00	6.03	6.10	0.2362	0.2374	0.2402

(续)

(螺纹加工 • M和MF — 续)

丝锥尺寸	螺距		65% 螺纹嵌合率						70% 螺纹嵌合率						75% 螺纹嵌合率					
			公制			英制			公制			英制			公制			英制		
			最小 钻径	理论值	最大 钻径	最小 钻径	理论值	最大 钻径	最小 钻径	理论值	最大 钻径	最小 钻径	理论值	最大 钻径	最小 钻径	理论值	最大 钻径	最小 钻径	理论值	最大 钻径
M8	1.25	-	6.90	6.94	7.00	0.2717	0.2732	0.2756	6.80	6.86	6.90	0.2677	0.2701	0.2717	6.75	6.78	6.80	0.2656	0.2669	0.2677
	-	1	7.15	7.16	7.20	0.2813	0.2819	0.2835	7.00	7.09	7.10	0.2756	0.2791	0.2795	7.00	7.03	7.10	0.2756	0.2768	0.2795
	-	0.75	7.30	7.37	7.40	0.2874	0.2902	0.2913	7.30	7.32	7.40	0.2874	0.2882	0.2913	7.20	7.27	7.30	0.2835	0.2862	0.2874
M10	1.5	-	8.70	8.73	8.73	0.3425	0.3437	0.3438	8.60	8.64	8.70	0.3386	0.3402	0.3425	8.50	8.54	8.60	0.3346	0.3362	0.3386
	-	1.25	8.90	8.94	9.00	0.3504	0.3520	0.3543	8.80	8.86	8.90	0.3465	0.3488	0.3504	8.73	8.78	8.80	0.3438	0.3457	0.3465
	-	1	9.13	9.16	9.20	0.3594	0.3606	0.3622	9.00	9.09	9.10	0.3543	0.3579	0.3583	9.00	9.03	9.10	0.3543	0.3555	0.3583
	-	0.75	9.35	9.37	9.40	0.3680	0.3689	0.3701	9.30	9.32	9.35	0.3661	0.3669	0.3680	9.20	9.27	9.30	0.3622	0.3650	0.3661
M12	1.75	-	10.50	10.52	10.60	0.4134	0.4142	0.4173	10.40	10.41	10.50	0.4094	0.4098	0.4134	10.30	10.30	10.30	0.4055	0.4055	0.4055
	-	1.5	10.72	10.73	10.80	0.4219	0.4224	0.4252	10.60	10.64	10.70	0.4173	0.4189	0.4213	10.50	10.54	10.60	0.4134	0.4150	0.4173
	-	1.25	10.90	10.94	11.00	0.4291	0.4307	0.4331	10.80	10.86	10.90	0.4252	0.4276	0.4291	10.72	10.78	10.80	0.4219	0.4244	0.4252
	-	1	11.15	11.16	11.20	0.4375	0.4394	0.4409	11.00	11.09	11.10	0.4331	0.4366	0.4370	11.00	11.03	11.10	0.4331	0.4343	0.4370
M14	2	-	12.30	12.31	12.40	0.4844	0.4846	0.4882	12.10	12.18	12.20	0.4764	0.4795	0.4803	12.00	12.05	12.10	0.4724	0.4744	0.4764
	-	1.5	12.70	12.73	12.80	0.5000	0.5012	0.5039	12.60	12.64	12.70	0.4961	0.4976	0.5000	12.50	12.54	12.60	0.4921	0.4937	0.4961
M16	2	-	14.20	14.31	14.50	0.5591	0.5634	0.5709	14.00	14.18	14.20	0.5512	0.5583	0.5591	14.00	14.05	14.20	0.5512	0.5531	0.5591
	-	1.5	14.50	14.73	15.00	0.5709	0.5799	0.5906	14.50	14.64	15.00	0.5709	0.5764	0.5906	14.50	14.54	15.00	0.5709	0.5724	0.5906
M18	2.5	-	15.80	15.89	16.00	0.6220	0.6256	0.6299	15.50	15.73	15.80	0.6102	0.6193	0.6220	15.50	15.56	15.80	0.6102	0.6126	0.6220
	-	1.5	16.50	16.73	17.00	0.6496	0.6587	0.6693	16.50	16.64	17.00	0.6496	0.6551	0.6693	16.50	16.54	17.00	0.6496	0.6512	0.6693
M20	2.5	-	17.50	17.89	18.00	0.6890	0.7043	0.7087	17.50	17.73	18.00	0.6890	0.6980	0.7087	17.50	17.56	18.00	0.6890	0.6913	0.7087
	-	1.5	18.50	18.73	19.00	0.7283	0.7374	0.7480	18.50	18.64	19.00	0.7283	0.7339	0.7480	18.50	18.54	19.00	0.7283	0.7299	0.7480
	-	1	19.00	19.16	19.50	0.7480	0.7543	0.7677	19.00	19.09	19.50	0.7480	0.7516	0.7677	19.00	19.03	19.50	0.7480	0.7492	0.7677
M22	2.5	-	19.50	19.89	20.00	0.7677	0.7831	0.7874	19.50	19.73	20.00	0.7677	0.7768	0.7874	19.50	19.56	20.00	0.7677	0.7701	0.7874
	-	2	20.00	20.31	20.50	0.7874	0.7996	0.8071	20.00	20.18	20.50	0.7874	0.7945	0.8071	20.00	20.05	20.50	0.7874	0.7894	0.8071
	-	1.5	20.50	20.73	21.00	0.8071	0.8161	0.8268	20.50	20.64	21.00	0.8071	0.8126	0.8268	20.50	20.54	21.00	0.8071	0.8087	0.8268
M24	3	-	21.43	21.47	21.50	0.8440	0.8453	0.8460	21.15	21.27	21.33	0.8327	0.8374	0.8398	21.00	21.08	21.15	0.8268	0.8299	0.8327
	-	2	22.23	22.31	22.44	0.8750	0.8783	0.8840	22.00	22.18	22.23	0.8661	0.8732	0.8750	22.00	22.05	22.23	0.8661	0.8681	0.8750
	-	1.5	22.50	22.73	22.77	0.8858	0.8949	0.8965	22.50	22.64	22.77	0.8858	0.8913	0.8965	22.50	22.54	22.77	0.8858	0.8874	0.8965
M27	3	-	24.30	24.47	24.50	0.9567	0.9634	0.9646	24.00	24.27	24.30	0.9449	0.9555	0.9567	24.00	24.08	24.30	0.9449	0.9480	0.9567
	-	2	25.07	25.31	25.40	0.9870	0.9965	1.0000	25.07	25.18	25.40	0.9870	0.9913	1.0000	25.00	25.05	25.07	0.9843	0.9862	0.9870
	-	1.5	25.67	25.73	25.81	1.0110	1.0130	1.0160	25.61	25.64	25.65	1.0080	1.0094	1.0098	25.50	25.54	25.60	1.0039	1.0055	1.0080
M30	3.5	-	27.00	27.04	27.50	1.0630	1.0646	1.0827	26.70	26.82	27.00	1.0512	1.0559	1.0610	26.59	26.59	26.59	1.0433	1.0469	1.0470
	-	2	28.18	28.31	28.50	1.1090	1.1146	1.1220	28.18	28.18	28.18	1.1090	1.1094	1.1220	28.00	28.05	28.10	1.1024	1.1043	1.1063
	-	1.5	28.58	28.73	29.00	1.1250	1.1311	1.1417	28.58	28.64	29.00	1.1250	1.1276	1.1417	28.50	28.54	28.58	1.1220	1.1236	1.1250
M33	3.5	-	30.00	30.04	30.16	1.1811	1.1827	1.1875	29.77	29.82	30.00	1.1720	1.1740	1.1811	29.50	29.59	29.73	1.1614	1.1650	1.1720
	-	2	31.00	31.31	31.50	1.2200	1.2327	1.2402	31.00	31.18	31.50	1.2200	1.2276	1.2402	31.00	31.05	31.50	1.2200	1.2224	1.2402
M36	4	-	32.54	32.62	32.94	1.2810	1.2843	1.2970	32.00	32.36	32.50	1.2598	1.2740	1.2795	32.00	32.10	32.50	1.2598	1.2638	1.2795
	-	3	33.40	33.47	33.50	1.3130	1.3177	1.3189	33.00	33.27	33.34	1.2992	1.3098	1.3130	33.00	33.08	33.34	1.2992	1.3024	1.3130
	-	2	34.13	34.31	34.50	1.3440	1.3508	1.3583	34.13	34.18	34.50	1.3440	1.3457	1.3583	34.00	34.05	34.13	1.3386	1.3406	1.3440
M39	4	-	35.50	35.62	35.72	1.3976	1.4024	1.4060	35.00	35.36	35.50	1.3780	1.3921	1.3976	35.00	35.10	35.50	1.3780	1.3819	1.3976
	-	2	37.31	37.31	37.31	1.4567	1.4689	1.4690	37.00	37.18	37.31	1.4567	1.4638	1.4690	37.00	37.05	37.31	1.4567	1.4587	1.4690
M42	4.5	-	38.10	38.20	38.46	1.5000	1.5039	1.5140	37.50	37.91	38.00	1.4764	1.4925	1.4961	37.50	37.62	38.00	1.4764	1.4811	1.4961
	-	3	39.00	39.47	39.50	1.5354	1.5539	1.5551	39.00	39.27	39.50	1.5354	1.5461	1.5551	39.00	39.08	39.50	1.5354	1.5386	1.5551
	-	2	40.00	40.31	41.00	1.5750	1.5870	1.6140	40.00	40.18	41.00	1.5750	1.5819	1.6140	40.00	40.05	41.00	1.5750	1.5768	1.6140



■ 挤压丝锥 • UNC和UNF

丝锥尺寸	螺距		65% 螺纹嵌合率						70% 螺纹嵌合率						75% 螺纹嵌合率					
			公制			英制			公制			英制			公制			英制		
			最小 钻径	理论值	最大 钻径	最小 钻径	理论值	最大 钻径	最小 钻径	理论值	最大 钻径	最小 钻径	理论值	最大 钻径	最小 钻径	理论值	最大 钻径	最小 钻径	理论值	最大 钻径
#0	-	80	1.32	1.38	1.40	0.0520	0.0545	0.0550	1.32	1.38	1.40	0.0520	0.0540	0.0550	1.32	1.36	1.40	0.0520	0.0536	0.0550
#1	64	-	1.60	1.68	1.70	0.0630	0.0661	0.0669	1.60	1.67	1.70	0.0630	0.0655	0.0669	1.60	1.65	1.70	0.0630	0.0650	0.0669
	-	72	1.70	1.70	1.70	0.0669	0.0669	0.0669	1.60	1.69	1.70	0.0630	0.0663	0.0669	1.60	1.67	1.70	0.0630	0.0659	0.0669
#2	56	-	1.98	1.98	1.98	0.0781	0.0781	0.0781	1.90	1.97	1.98	0.0748	0.0774	0.0781	1.90	1.95	1.98	0.0748	0.0769	0.0781
	-	64	2.00	2.01	2.10	0.0787	0.0791	0.0827	2.00	2.00	2.00	0.0781	0.0785	0.0787	1.98	1.98	1.98	0.0748	0.0780	0.0781
#3	48	-	2.20	2.28	2.30	0.0866	0.0898	0.0906	2.20	2.27	2.30	0.0866	0.0890	0.0906	2.20	2.25	2.30	0.0866	0.0884	0.0906
	-	56	2.30	2.31	2.38	0.0906	0.0911	0.0938	2.30	2.31	2.38	0.0866	0.0904	0.0906	2.20	2.28	2.30	0.0866	0.0899	0.0906
#4	40	-	2.50	2.57	2.58	0.0984	0.1010	0.1015	2.50	2.55	2.58	0.0984	0.1000	0.1015	2.50	2.52	2.58	0.0984	0.0993	0.1015
	-	48	2.60	2.61	2.64	0.1024	0.1028	0.1040	2.60	2.60	2.60	0.1015	0.1020	0.1024	2.58	2.58	2.58	0.0984	0.1014	0.1015
#5	40	-	2.90	2.90	2.90	0.1130	0.1140	0.1142	2.87	2.88	2.90	0.1130	0.1130	0.1130	2.82	2.85	2.87	0.1110	0.1123	0.1130
	-	44	2.90	2.92	2.95	0.1142	0.1150	0.1160	2.90	2.91	2.95	0.1130	0.1141	0.1142	2.87	2.88	2.90	0.1130	0.1134	0.1142
#6	32	-	3.10	3.16	3.18	0.1220	0.1243	0.1250	3.10	3.14	3.18	0.1220	0.1230	0.1250	3.10	3.10	3.10	0.1220	0.1221	0.1250
	-	40	3.20	3.23	3.26	0.1260	0.1270	0.1285	3.20	3.21	3.26	0.1260	0.1260	0.1260	3.18	3.18	3.18	0.1250	0.1253	0.1260
#8	32	-	3.80	3.82	3.90	0.1496	0.1503	0.1535	3.80	3.80	3.80	0.1470	0.1490	0.1496	3.73	3.76	3.80	0.1470	0.1481	0.1496
	-	36	3.80	3.86	3.90	0.1496	0.1518	0.1535	3.80	3.84	3.90	0.1496	0.1507	0.1535	3.80	3.80	3.80	0.1496	0.1498	0.1535
#10	24	-	4.30	4.36	4.37	0.1693	0.1716	0.1719	4.30	4.34	4.37	0.1693	0.1700	0.1719	4.22	4.29	4.30	0.1660	0.1688	0.1693
	-	32	4.40	4.48	4.50	0.1732	0.1762	0.1772	4.40	4.46	4.50	0.1732	0.1750	0.1772	4.40	4.42	4.50	0.1732	0.1741	0.1772
#12	24	-	5.00	5.02	5.10	0.1969	0.1976	0.2008	5.00	5.00	5.00	0.1929	0.1960	0.1969	4.90	4.95	5.00	0.1929	0.1948	0.1969
	-	28	5.00	5.09	5.10	0.1969	0.2002	0.2008	5.00	5.07	5.10	0.1969	0.1990	0.2008	5.00	5.02	5.10	0.1969	0.1978	0.2008
1/4	20	-	5.70	5.79	5.80	0.2244	0.2279	0.2283	5.70	5.76	5.80	0.2244	0.2260	0.2283	5.70	5.70	5.70	0.2244	0.2245	0.2283
	-	28	5.95	5.95	5.95	0.2323	0.2342	0.2344	5.90	5.94	5.95	0.2323	0.2329	0.2344	5.80	5.89	5.90	0.2283	0.2318	0.2323
5/16	18	-	7.30	7.31	7.40	0.2874	0.2879	0.2913	7.30	7.30	7.30	0.2835	0.2861	0.2874	7.20	7.22	7.30	0.2835	0.2842	0.2874
	-	24	7.40	7.47	7.50	0.2913	0.2941	0.2953	7.40	7.46	7.50	0.2913	0.2927	0.2953	7.40	7.40	7.40	0.2874	0.2912	0.2913
3/8	16	-	8.80	8.82	8.90	0.3465	0.3474	0.3504	8.80	8.80	8.80	0.3438	0.3452	0.3465	8.70	8.71	8.73	0.3425	0.3431	0.3438
	-	24	9.00	9.06	9.10	0.3543	0.3566	0.3583	9.00	9.06	9.10	0.3543	0.3552	0.3583	8.90	8.98	9.00	0.3504	0.3537	0.3543
7/16	14	-	10.30	10.31	10.32	0.4055	0.4059	0.4063	10.20	10.29	10.30	0.4016	0.4035	0.4055	10.10	10.19	10.20	0.3976	0.4011	0.4016
	-	20	10.50	10.55	10.60	0.4134	0.4154	0.4173	10.50	10.55	10.60	0.4134	0.4137	0.4173	10.40	10.46	10.50	0.4094	0.4120	0.4134
1/2	13	-	11.80	11.84	11.90	0.4646	0.4660	0.4685	11.80	11.82	11.90	0.4606	0.4634	0.4646	11.70	11.70	11.70	0.4606	0.4608	0.4646
	-	20	12.10	12.14	12.20	0.4764	0.4779	0.4803	12.10	12.14	12.20	0.4724	0.4762	0.4764	12.00	12.05	12.10	0.4724	0.4745	0.4764
9/16	12	-	13.10	13.35	13.50	0.5157	0.5257	0.5315	13.10	13.33	13.50	0.5157	0.5229	0.5315	13.10	13.21	13.50	0.5157	0.5200	0.5315
	-	18	13.50	13.66	13.80	0.5315	0.5379	0.5433	13.50	13.67	13.80	0.5315	0.5361	0.5433	13.50	13.57	13.80	0.5315	0.5342	0.5433
5/8	11	-	14.50	14.85	15.00	0.5709	0.5848	0.5906	14.50	14.83	15.00	0.5709	0.5817	0.5906	14.50	14.70	15.00	0.5709	0.5787	0.5906
	-	18	15.10	15.25	15.50	0.5945	0.6004	0.6102	15.10	15.26	15.50	0.5945	0.5986	0.6102	15.10	15.16	15.50	0.5945	0.5967	0.6102
3/4	10	-	17.50	17.93	18.00	0.6890	0.7058	0.7087	17.50	17.91	18.00	0.6890	0.7024	0.7087	17.50	17.75	18.00	0.6890	0.6990	0.7087
	-	16	18.00	18.35	18.50	0.7087	0.7224	0.7283	18.00	18.37	18.50	0.7087	0.7202	0.7283	18.00	18.24	18.50	0.7087	0.7181	0.7283
7/8	9	-	20.50	20.98	21.00	0.8071	0.8259	0.8268	20.50	20.96	21.00	0.8071	0.8221	0.8268	20.50	20.78	21.00	0.8071	0.8183	0.8268
	-	14	21.33	21.42	21.43	0.8398	0.8434	0.8440	21.43	21.45	21.50	0.8398	0.8410	0.8440	21.15	21.30	21.33	0.8327	0.8386	0.8398
1	8	-	24.00	24.00	24.00	0.9380	0.9448	0.9449	23.81	23.98	24.00	0.9380	0.9405	0.9449	23.50	23.78	23.81	0.9252	0.9363	0.9375
	-	12	24.30	24.47	24.50	0.9567	0.9632	0.9646	24.30	24.49	24.50	0.9567	0.9603	0.9646	24.30	24.32	24.50	0.9567	0.9575	0.9646

攻丝

■ 挤压丝锥 • M和MF

丝锥尺寸	螺距		65% 螺纹嵌合率						70% 螺纹嵌合率						75% 螺纹嵌合率					
			公制			英制			公制			英制			公制			英制		
			最小 钻径	理论值	最大 钻径	最小 钻径	理论值	最大 钻径	最小 钻径	理论值	最大 钻径	最小 钻径	理论值	最大 钻径	最小 钻径	理论值	最大 钻径	最小 钻径	理论值	最大 钻径
M1.6	0.35	-	1.40	1.45	1.50	0.0551	0.0571	0.0591	1.40	1.43	1.50	0.0551	0.0563	0.0591	1.40	1.42	1.50	0.0551	0.0559	0.0591
M1.7	0.35	-	1.50	1.58	1.60	0.0591	0.0623	0.0630	1.50	1.57	1.60	0.0591	0.0620	0.0630	1.50	1.56	1.60	0.0591	0.0617	0.0630
M1.8	0.35	-	1.60	1.65	1.70	0.0630	0.0650	0.0669	1.60	1.63	1.70	0.0630	0.0642	0.0669	1.60	1.62	1.70	0.0630	0.0638	0.0669
M2	0.4	-	1.80	1.82	1.90	0.0709	0.0717	0.0748	1.80	1.81	1.90	0.0709	0.0713	0.0748	1.80	1.80	1.80	0.0709	0.0709	0.0709
M2.2	0.45	-	2.00	2.00	2.00	0.0787	0.0787	0.0787	1.98	1.99	2.00	0.0781	0.0783	0.0787	1.90	1.97	1.98	0.0748	0.0776	0.0781
M2.5	0.45	-	2.30	2.30	2.30	0.0906	0.0906	0.0906	2.20	2.29	2.30	0.0866	0.0902	0.0906	2.20	2.27	2.30	0.0866	0.0894	0.0906
M2.6	0.45	-	2.40	2.43	2.44	0.0945	0.0957	0.0960	2.40	2.42	2.44	0.0945	0.0953	0.0960	2.40	2.41	2.44	0.0945	0.0949	0.0960
M3	0.5	-	2.78	2.78	2.80	0.1094	0.1094	0.1094	2.71	2.76	2.78	0.1065	0.1087	0.1094	2.71	2.75	2.78	0.1065	0.1083	0.1094
	-	0.35	2.87	2.88	2.90	0.1130	0.1134	0.1142	2.87	2.87	2.87	0.1130	0.1130	0.1130	2.82	2.86	2.87	0.1110	0.1126	0.1130
M3.5	0.6	-	3.20	3.23	3.26	0.1260	0.1272	0.1285	3.20	3.21	3.26	0.1260	0.1264	0.1285	3.18	3.19	3.20	0.1250	0.1256	0.1260
M4	0.7	-	3.66	3.69	3.70	0.1440	0.1453	0.1457	3.66	3.67	3.70	0.1440	0.1445	0.1457	3.60	3.64	3.66	0.1417	0.1433	0.1440
	-	0.5	3.73	3.78	3.80	0.1470	0.1488	0.1496	3.73	3.76	3.80	0.1470	0.1480	0.1496	3.73	3.75	3.80	0.1470	0.1476	0.1496
M4.5	0.75	-	4.10	4.17	4.20	0.1614	0.1642	0.1654	4.10	4.14	4.20	0.1614	0.1630	0.1654	4.10	4.12	4.20	0.1614	0.1622	0.1654
M5	0.8	-	4.62	4.65	4.70	0.1820	0.1831	0.1850	4.60	4.62	4.62	0.1811	0.1819	0.1820	4.50	4.59	4.60	0.1772	0.1807	0.1811
	-	0.5	4.76	4.78	4.80	0.1875	0.1882	0.1890	4.70	4.76	4.76	0.1850	0.1874	0.1875	4.70	4.75	4.76	0.1850	0.1870	0.1875
M6	1	-	5.56	5.56	5.60	0.2188	0.2189	0.2205	5.50	5.52	5.56	0.2165	0.2173	0.2188	5.41	5.49	5.50	0.2130	0.2161	0.2165
	-	0.75	5.62	5.67	5.70	0.2211	0.2232	0.2244	5.62	5.64	5.70	0.2211	0.2220	0.2244	5.62	5.62	5.70	0.2211	0.2213	0.2244
M7	1	-	6.53	6.56	6.60	0.2570	0.2583	0.2598	6.50	6.52	6.53	0.2559	0.2567	0.2570	6.40	6.49	6.50	0.2520	0.2555	0.2559
M8	1.25	-	7.40	7.45	7.50	0.2913	0.2933	0.2953	7.40	7.41	7.50	0.2913	0.2917	0.2953	7.30	7.36	7.40	0.2874	0.2898	0.2913
	-	1	7.54	7.56	7.60	0.2969	0.2976	0.2992	7.50	7.52	7.54	0.2953	0.2961	0.2969	7.40	7.49	7.50	0.2913	0.2949	0.2953
	-	0.75	7.60	7.67	7.70	0.2992	0.3020	0.3031	7.60	7.64	7.70	0.2992	0.3008	0.3031	7.60	7.62	7.70	0.2992	0.3000	0.3031
M10	1.5	-	9.30	9.34	9.35	0.3661	0.3677	0.3680	9.20	9.29	9.30	0.3622	0.3657	0.3661	9.20	9.24	9.30	0.3622	0.3638	0.3661
	-	1.25	9.40	9.45	9.50	0.3701	0.3720	0.3740	9.40	9.41	9.50	0.3701	0.3705	0.3740	9.35	9.36	9.40	0.3680	0.3685	0.3701
	-	1	9.53	9.56	9.60	0.3750	0.3764	0.3780	9.50	9.52	9.53	0.3740	0.3748	0.3750	9.40	9.49	9.50	0.3701	0.3736	0.3740
	-	0.75	9.60	9.67	9.70	0.3780	0.3807	0.3819	9.60	9.64	9.70	0.3780	0.3795	0.3819	9.60	9.62	9.70	0.3780	0.3787	0.3819
M12	1.75	-	11.20	11.23	11.30	0.4409	0.4421	0.4449	11.15	11.17	11.20	0.4375	0.4398	0.4409	11.10	11.11	11.15	0.4370	0.4374	0.4375
	-	1.5	11.30	11.34	11.40	0.4449	0.4465	0.4488	11.20	11.29	11.30	0.4449	0.4484	0.4488	11.20	11.24	11.30	0.4409	0.4425	0.4449
	-	1.25	11.40	11.45	11.50	0.4488	0.4508	0.4528	11.40	11.41	11.50	0.4488	0.4492	0.4528	11.30	11.36	11.40	0.4449	0.4472	0.4488
	-	1	11.51	11.56	11.60	0.4531	0.4551	0.4567	11.51	11.52	11.60	0.4531	0.4535	0.4567	11.40	11.49	11.50	0.4488	0.4524	0.4528
M14	2	-	13.10	13.12	13.50	0.5157	0.5165	0.5315	13.00	13.05	13.10	0.5118	0.5138	0.5157	12.80	12.98	13.00	0.5039	0.5110	0.5118
	-	1.5	13.10	13.34	13.50	0.5157	0.5252	0.5315	13.10	13.29	13.50	0.5157	0.5232	0.5315	13.10	13.24	13.50	0.5157	0.5213	0.5315
M16	2	-	15.10	15.12	15.50	0.5945	0.5953	0.6102	15.00	15.05	15.10	0.5906	0.5925	0.5945	14.50	14.98	15.00	0.5709	0.5898	0.5906
	-	1.5	15.10	15.34	15.50	0.5945	0.6039	0.6102	15.10	15.29	15.50	0.5945	0.6020	0.6102	15.10	15.24	15.50	0.5945	0.6000	0.6102
M18	2.5	-	16.50	16.90	17.00	0.6496	0.6654	0.6693	16.50	16.81	17.00	0.6496	0.6618	0.6693	16.50	16.73	17.00	0.6496	0.6587	0.6693
	-	1.5	17.00	17.34	17.50	0.6693	0.6827	0.6890	17.00	17.29	17.50	0.6693	0.6807	0.6890	17.00	17.24	17.50	0.6693	0.6787	0.6890
M20	2.5	-	18.50	18.90	19.00	0.7283	0.7441	0.7480	18.50	18.81	19.00	0.7283	0.7406	0.7480	18.50	18.73	19.00	0.7283	0.7374	0.7480
	-	1.5	19.00	19.34	19.50	0.7480	0.7614	0.7677	19.00	19.29	19.50	0.7480	0.7594	0.7677	19.00	19.24	19.50	0.7480	0.7575	0.7677
-	1	19.50	19.56	20.00	0.7677	0.7701	0.7874	19.50	19.52	20.00	0.7677	0.7685	0.7874	19.00	19.49	19.50	0.7480	0.7673	0.7677	
M22	2.5	-	20.50	20.90	21.00	0.8071	0.8228	0.8268	20.50	20.81	21.00	0.8071	0.8193	0.8268	20.50	20.73	21.00	0.8071	0.8161	0.8268
	-	2	21.00	21.12	21.15	0.8268	0.8315	0.8327	21.00	21.05	21.15	0.8268	0.8287	0.8327	20.50	20.98	21.00	0.8071	0.8260	0.8268
	-	1.5	21.33	21.34	21.43	0.8398	0.8402	0.8440	21.15	21.29	21.33	0.8327	0.8382	0.8398	21.15	21.24	21.33	0.8327	0.8362	0.8398
M24	3	-	22.50	22.67	22.77	0.8858	0.8925	0.8965	22.50	22.57	22.77	0.8858	0.8886	0.8965	22.44	22.47	22.50	0.8840	0.8846	0.8858
	-	2	23.10	23.12	23.30	0.9094	0.9102	0.9173	23.00	23.05	23.10	0.9055	0.9075	0.9094	22.77	22.98	23.00	0.8965	0.9047	0.9055
	-	1.5	23.30	23.34	23.42	0.9173	0.9189	0.9220	23.10	23.29	23.30	0.9094	0.9169	0.9173	23.10	23.24	23.30	0.9094	0.9150	0.9173



■ 管螺纹

管螺纹尺寸	NPT 和 NPTF		NPSM	NPSC	NPSF
	不使用铰刀	使用铰刀			
1/16-27	0.2420	0.2344	—	0.2500	0.2460
1/8-27	0.3320	0.3281	0.3580	0.3320	0.3390
1/4-18	0.4375	0.4219	0.4688	0.4375	0.4375
3/8-18	0.5625	0.5625	0.6030	0.5781	0.5781
1/2-14	0.7031	0.6875	0.7480	0.7087	0.7087
3/4-14	0.9063	0.8906	0.9531	0.9219	0.9219
1-11 1/2	1.1406	1.1250	1.2031	1.1563	1.1563
1 1/4-11 1/2	1.4844	1.4688	1.5460	1.5000	—
1 1/2-11 1/2	1.7188	1.7031	1.7813	1.7344	—
2-11 1/2	2.1875	2.1719	2.2500	2.2031	—

通孔向前推出切屑

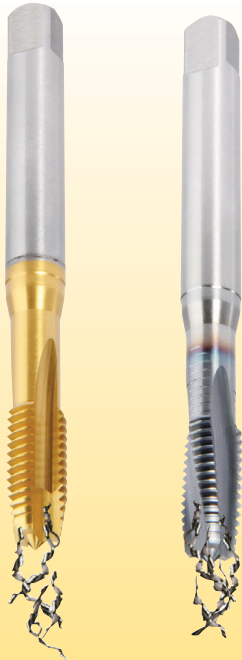

刃倾角

LHSF



- 刃倾角或 LHSF 型（左手螺旋槽）。
- 适合长切屑型材料。

盲孔向后排屑



RHSF



- RHSF（右手螺旋槽）。
- 适合长切屑型材料。

盲孔或通孔存储切屑



STFL



- STFL（直槽）。
- 适合短切屑型材料。

盲孔或通孔无切屑



挤压丝锥



- 成型加工。
- 特别适合延展性材料加工 <32 HRC.

■ 统一标准英制螺纹

螺纹尺寸/牙距	推荐丝锥限度 ¹		内螺栓中径限度		
	2B 级	3B 级	所有级别最小值 (基本型)	2B 级最大值	3B 级最大值
0 - 80	H2	H2	0.0519	0.0542	0.0536
1 - 64	H2	H2	0.0629	0.0655	0.0648
1 - 72	H2	H2	0.0640	0.0665	0.0659
2 - 56	H2	H2	0.0744	0.0772	0.0765
2 - 64	H2	H2	0.0759	0.0786	0.0779
3 - 48	H3	H2	0.0855	0.0885	0.0877
3 - 56	H2	H2	0.0874	0.0902	0.0895
4 - 40	H3	H2	0.0958	0.0991	0.0982
4 - 48	H3	H2	0.0985	0.1016	0.1008
5 - 40	H3	H2	0.1088	0.1121	0.1113
5 - 44	H3	H2	0.1102	0.1134	0.1126
6 - 32	H3	H2	0.1177	0.1214	0.1204
6 - 40	H3	H2	0.1218	0.1252	0.1243
8 - 32	H3	H3	0.1437	0.1475	0.1465
8 - 36	H3	H3	0.1460	0.1496	0.1487
10 - 24	H3	H3	0.1629	0.1672	0.1661
10 - 32	H3	H3	0.1697	0.1736	0.1726
12 - 24	H3	H3	0.1889	0.1933	0.1922
12 - 28	H3	H3	0.1928	0.1970	0.1959
1/4 - 20	H5	H3	0.2175	0.2224	0.2211
1/4 - 28	H4	H3	0.2268	0.2311	0.2300
5/16 - 18	H5	H3	0.2764	0.2817	0.2803
5/16 - 24	H4	H3	0.2854	0.2902	0.2890
3/8 - 16	H5	H3	0.3344	0.3401	0.3387
3/8 - 24	H4	H3	0.3479	0.3528	0.3516
7/16 - 14	H5	H3	0.3911	0.3972	0.3957
7/16 - 20	H5	H3	0.4050	0.4104	0.4091
1/2 - 13	H5	H4	0.4500	0.4565	0.4548
1/2 - 20	H5	H3	0.4675	0.4731	0.4717
9/16 - 12	H5	H4	0.5084	0.5152	0.5135
9/16 - 18	H5	H3	0.5264	0.5323	0.5308
5/8 - 11	H5	H4	0.5660	0.5732	0.5714
5/8 - 18	H5	H3	0.5889	0.5949	0.5934
3/4 - 10	H5	H4	0.6850	0.6927	0.6907

(续)

¹选择用于 3B 级别的 H 限度丝锥也可加工 2B 级别的螺纹。

注: 以上推荐的丝锥在正常使用的情况下, 可在普通材料的加工中形成指定类别的螺纹。
但是, 如果指定丝锥不具备满意的配合精度, 可以选择备用丝锥限度值。

攻丝

■ 统一标准英制螺纹 (续)

螺纹尺寸/牙距	推荐丝锥限度 ¹		内螺柱中径限度		
	2B 级	3B 级	所有级别最小值 (基本型)	2B 级最大值	3B 级最大值
3/4 - 16	H5	H4	0.7094	0.7159	0.7143
7/8 - 9	H6	H4	0.8028	0.8110	0.8089
7/8 - 14	H6	H4	0.8286	0.8356	0.8339
1" - 8	H6	H5	0.9188	0.9276	0.9254
1" - 12	H6	H4	0.9459	0.9535	0.9516
1-1/8 - 7	H8	H6	1.0322	1.0416	1.0393
1-1/8 - 8	H8	H6	1.0438	1.0528	1.0505
1-1/8 - 12	H6	H5	1.0709	1.0787	1.0768
1-1/4 - 7	H8	H6	1.1572	1.1668	1.1644
1-1/4 - 8	H8	H6	1.1688	1.1780	1.1757
1-1/4 - 12	H6	H5	1.1959	1.2039	1.2019
1-3/8 - 6	H8	H6	1.2667	1.2771	1.2745
1-3/8 - 8	H8	H6	1.2938	1.3031	1.3008
1-3/8 - 12	H6	H5	1.3209	1.3291	1.3270
1-1/2 - 6	H8	H6	1.3917	1.4022	1.3996
1-1/2 - 8	H8	H6	1.4188	1.4283	1.4259
1-1/2 - 12	H6	H5	1.4459	1.4542	1.4522
1-3/4 - 5	H8	H7	1.6201	1.6317	1.6288
2 - 4 1/2	H8	H7	1.8557	1.8681	1.8650

¹选择用于 3B 级别的 H 限度丝锥也可加工 2B 级别的螺纹。

■ 用于 6H 类别公制螺纹加工的推荐丝锥

螺纹尺寸		推荐丝锥	内螺柱产品限度 — 6H 级			
标称直径 (mm)	螺距 (mm)		限度值	中径 (mm)		中径 (in)
			最小值	最大值	最小值	最大值
1,6	0,35	D3	1,373	1,458	.05406	.05740
2	0,4	D3	1,740	1,830	.06850	.07205
2,5	0,45	D3	2,208	2,303	.08693	.09067
3	0,5	D3	2,675	2,775	.10531	.10925
3,5	0,6	D4	3,110	3,222	.12244	.12685
4	0,7	D4	3,545	3,663	.13957	.14421
4,5	0,75	D4	4,013	4,131	.15789	.16264
5	0,8	D4	4,480	4,605	.17638	.18130
6	1	D5	5,350	5,500	.21063	.21654
7	1	D5	6,350	6,500	.25000	.25591
8	1,25	D5	7,188	7,348	.28299	.28929
10	1,5	D6	9,026	9,206	.35535	.36244
12	1,75	D6	10,863	11,063	.42768	.43555
14	2	D7	12,701	12,913	.50004	.50839
16	2	D7	14,701	14,913	.57878	.58713
20	2,5	D7	18,376	18,600	.72346	.73228
24	3	D8	22,051	22,316	.86815	.87858
30	3,5	D9	27,727	28,007	1.09161	1.10264
36	4	D9	33,402	33,702	1.31504	1.32685

在为特定加工任务选择磨削螺纹丝锥时，除了丝锥的标称尺寸和牙距以外，还有另外一个重要的尺寸参数应当考虑。这个参数是螺纹中径公差“H”和“L”。“H”表示高于基本中径值；“L”表示低于基本中径值。设定丝锥公差是为了选择良好规格的丝锥产品，从而加工出预期类型的螺纹。

图一 描述了编号系统以及相连限度之间的 0.0005 英寸增量。因为初始点为基本中径，以千分之英寸为单位将公差值分为两个数值，确定了“H”系列中超过基本中径的zui大丝锥中径值，以及“L”系列中低于基本中径的最小丝锥中径值。

图二 描述了与各种类型，规格为 1/4-20 螺纹相关的丝锥公差定位。

图一

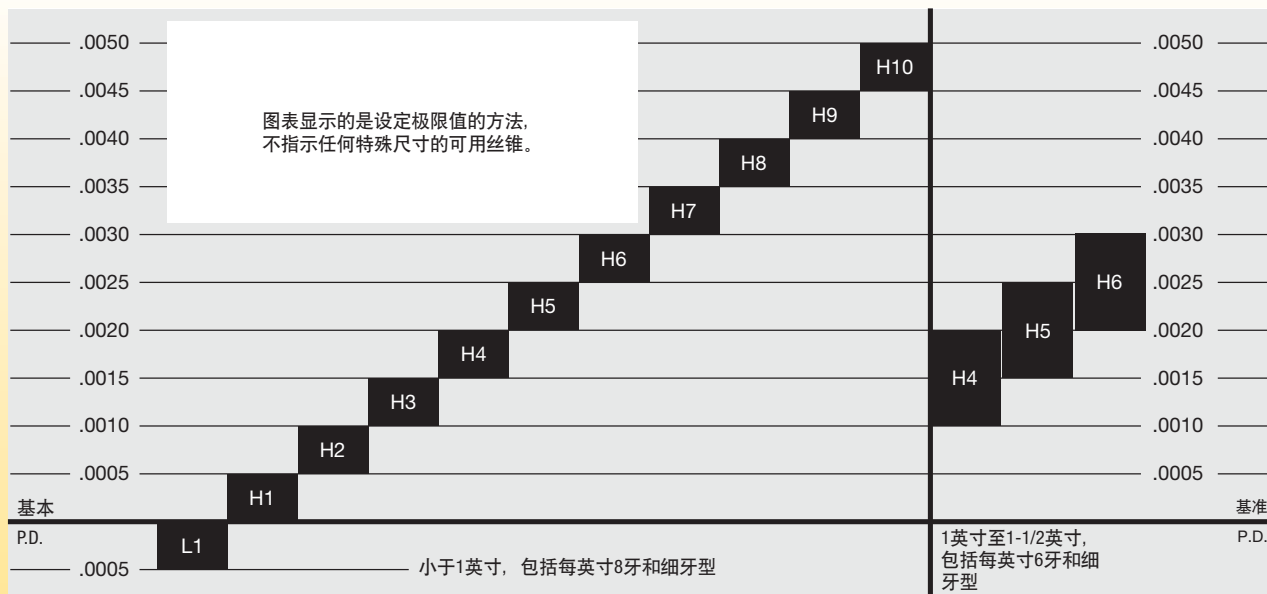

图二

UNC1/4-20和NC螺纹等级

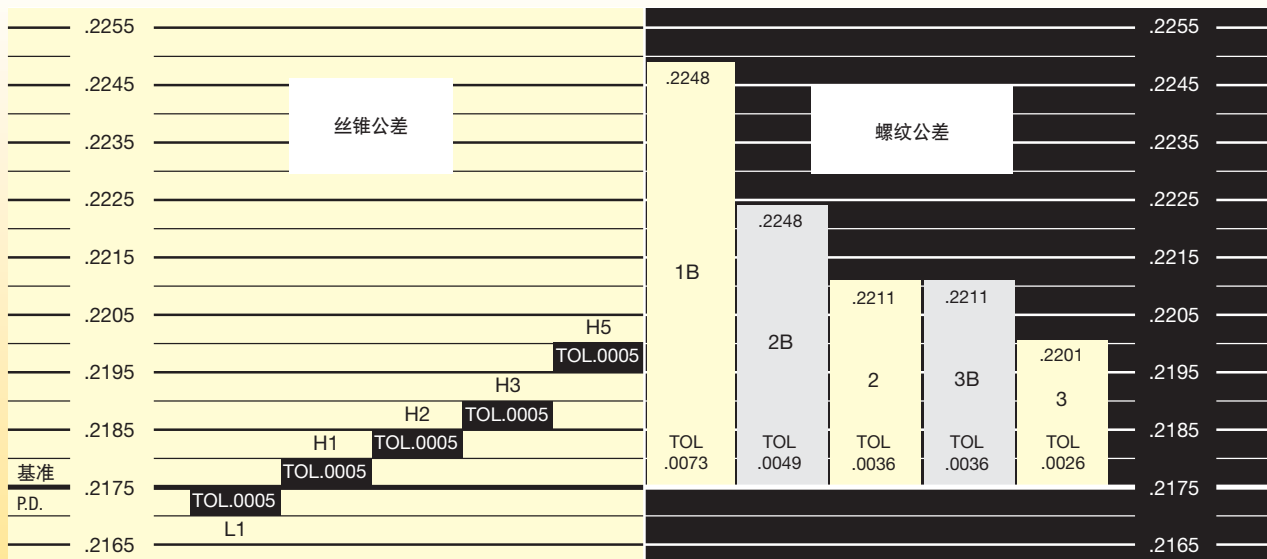

+ μm

统一内螺纹

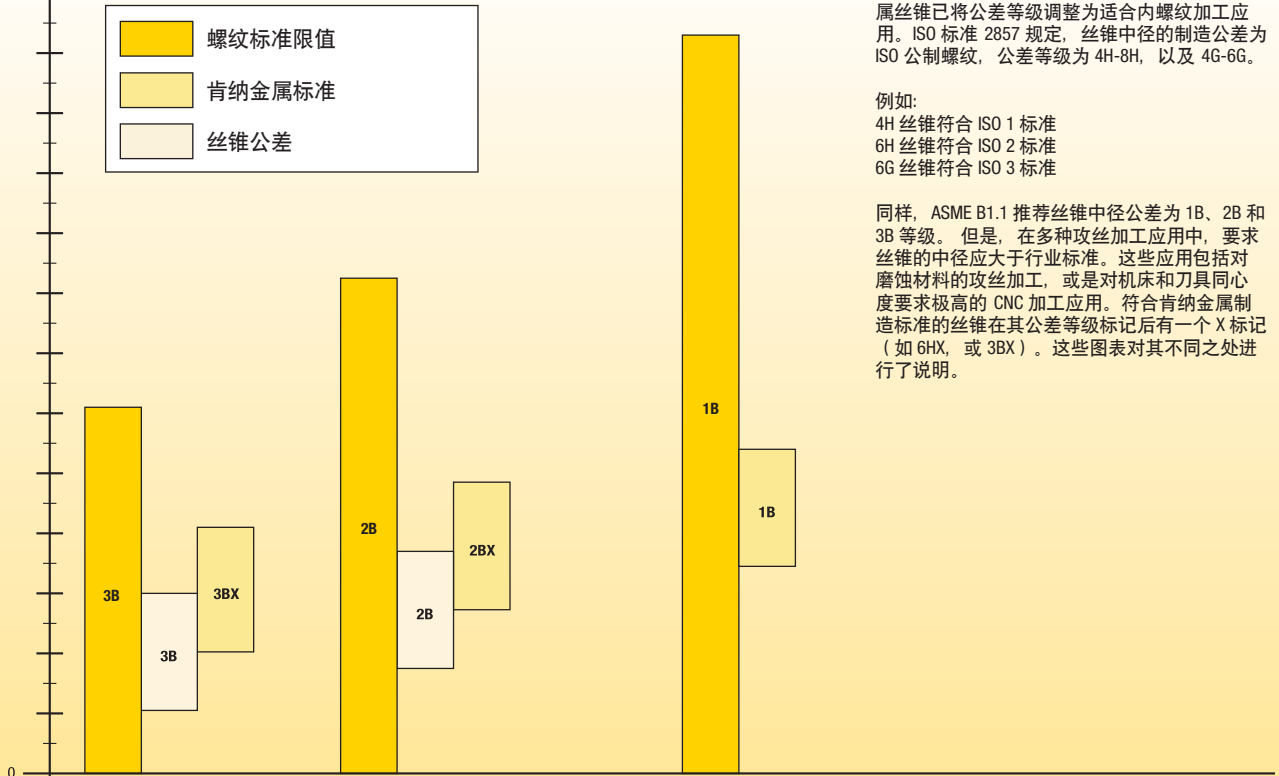
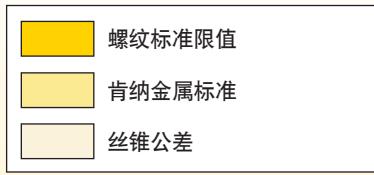

为了方便丝锥使用人的操作，新一代的肯纳金属丝锥已将公差等级调整为适合内螺纹加工应用。ISO 标准 2857 规定，丝锥中径的制造公差为 ISO 公制螺纹，公差等级为 4H-8H，以及 4G-6G。

例如：
4H 丝锥符合 ISO 1 标准
6H 丝锥符合 ISO 2 标准
6G 丝锥符合 ISO 3 标准

同样，ASME B1.1 推荐丝锥中径公差为 1B、2B 和 3B 等级。但是，在多种攻丝加工应用中，要求丝锥的中径应大于行业标准。这些应用包括对磨蚀材料的攻丝加工，或是对机床和刀具同心度要求极高的 CNC 加工应用。符合肯纳金属制造标准的丝锥在其公差等级标记后有一个 X 标记（如 6HX，或 3BX）。这些图表对其不同之处进行了说明。

公称中径直径（基准）

+ μm

公制内螺纹

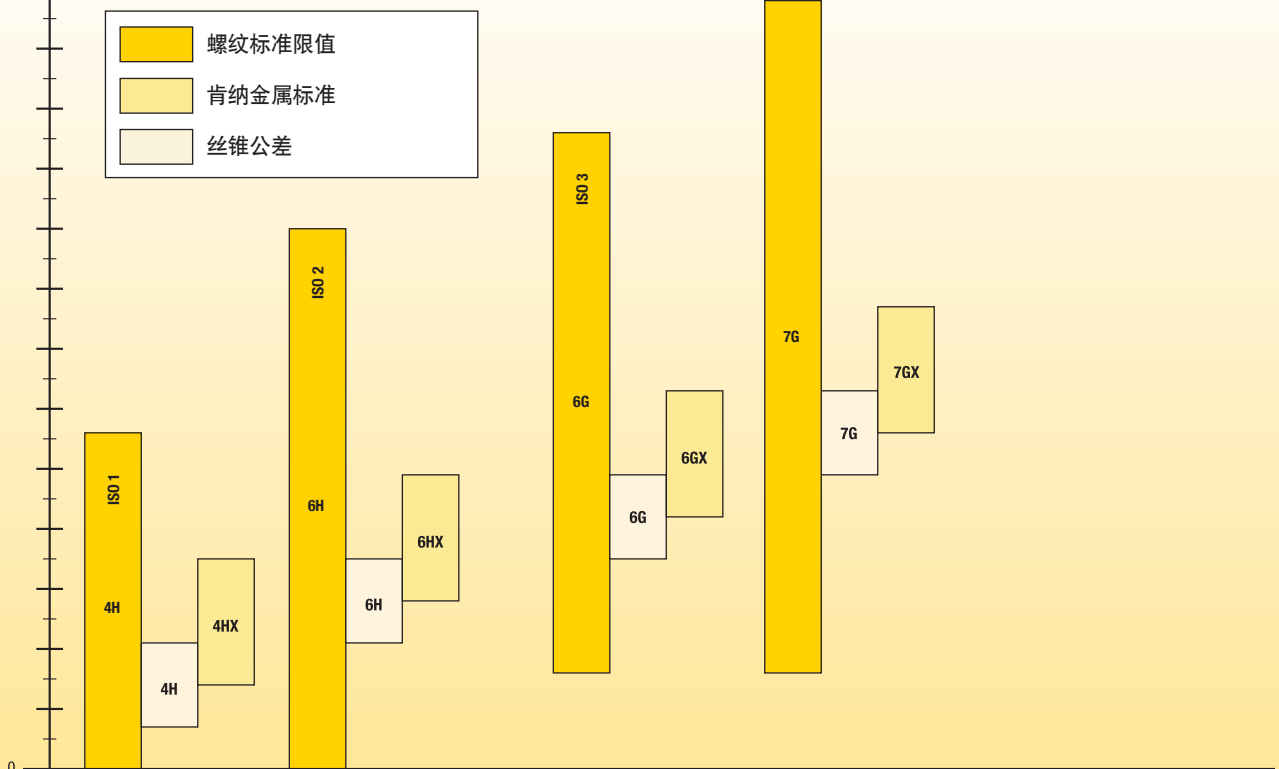
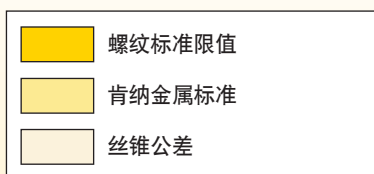

公称中径直径（基准）

在批量生产过程中，产品不可能完全具备图纸中标定的理论参数。图纸中的理论参数与实际产品之间出现许可范围内的略微差别被称为公差。

公差

配合零件之间预留的尺寸差。这个尺寸差是配合零件之间相距的最小距离或是接触的zui大距离。

螺纹角

螺纹两侧面之间的夹角，在轴向平面上测量。

半螺纹角

螺纹一个侧面与轴向垂直线之间的夹角，在轴向平面上测量。

螺纹导程

螺纹转动一圈的轴向距离。在单线螺纹中，导程与螺距相同。在双线螺纹中，导程为螺距的2倍；在三线螺纹中，导程为螺距的3倍，以此类推。

大径

直螺纹的zui大直径。

小径

直螺纹的zui小直径。

牙距

相邻二牙在中径线上对应二点间的轴向距离。

$$\text{英寸螺距} = \frac{1}{\text{每英寸螺纹牙数}}$$

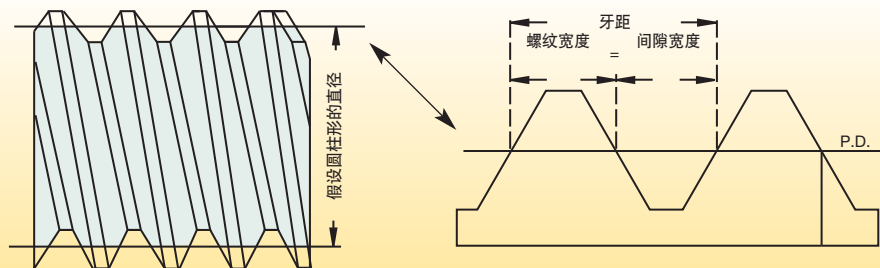
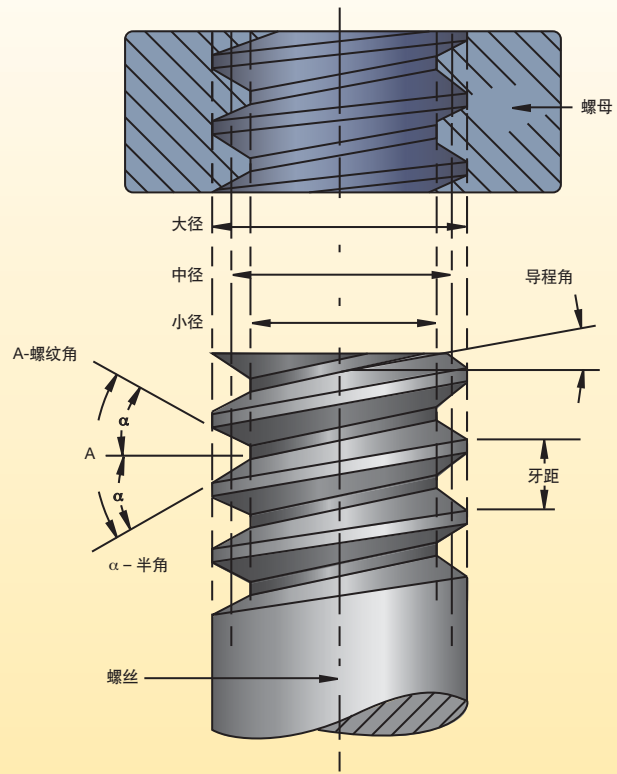

中径

在直螺纹上穿过螺纹的虚拟圆柱面所处的位置为螺距宽度与圆柱表面去除后的表面宽度相等。

一种适合航天工业以及其它对抗疲劳强度有较高要求应用的螺纹系统。UNJ 螺纹牙型符合 ASME B1.15 标准，并与军用 MIL-S-8879 标准非常相似。螺纹装配件包括外螺纹和内螺纹。为了减少 UNJ 外螺纹上的应力，采用了相当于 0.15011P - 0.18042P 的可控牙底圆角，其中 P 为螺纹螺距。UNJ 内螺纹不要在其大径处或小径处有圆角。

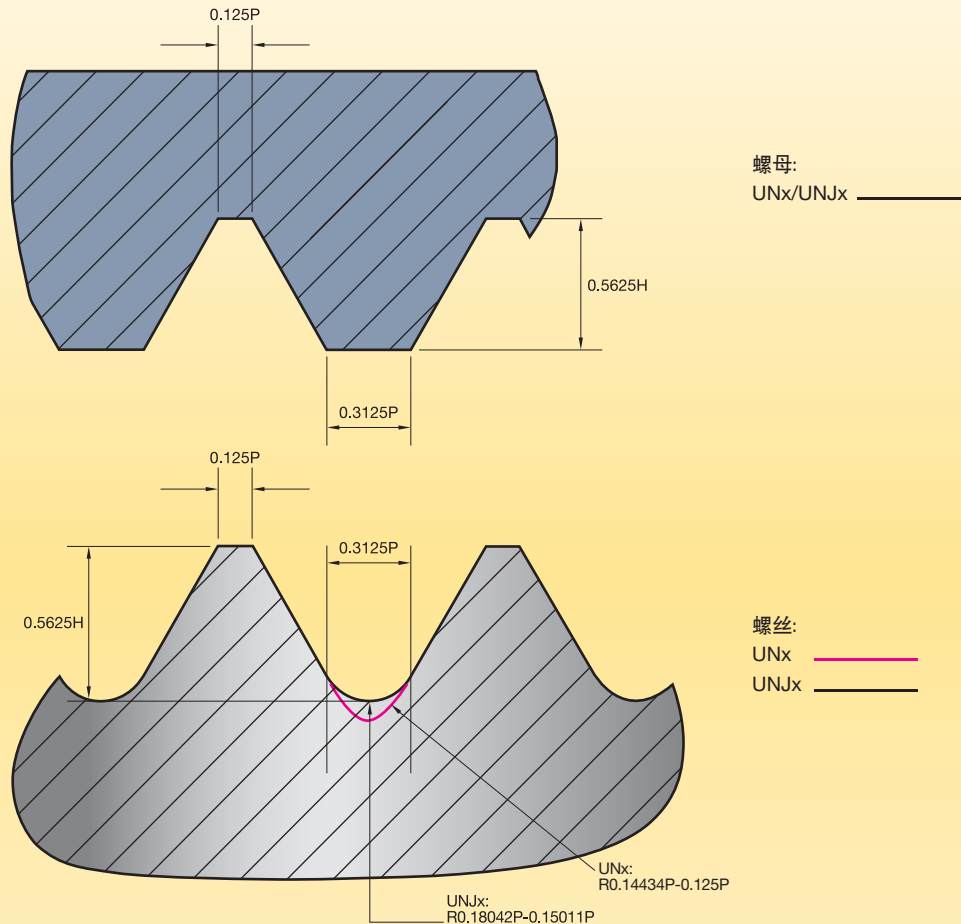

因为 UNJ 外螺纹在加工过程中需要确定的牙底半径，可能不能使用标准型 UN 刀具。但是，UNF 内螺纹在加工过程中可以使用磨削螺纹 UN 丝锥，并且具有适当的公差等级。不需要在丝锥上标记字母 J。必须对螺孔钻特别注意，因为需要标记出小径值，从而可提供牙底半径与外螺纹之间的间隙值。

了解 UNJ 螺纹参数，读者可以参考 ASME B1.15。请注意，该标准包括三级和二级 UNJ 螺纹。但是，仅有三级 UNJ 螺纹符合军用 MIL-S-8879 标准中的规定。了解统一英制 (UN) 螺纹参数，请参看 ASME B1.1。

与用来进行材料去除的切削丝锥不同，挤压丝锥可将材料移位并形成V型螺纹，从而加工出内螺纹。一种常见的误解是人们认为在加工中出现了螺纹滚轧过程。相反，在丝锥旋转进入孔内时，在丝锥锥形进刀处上方会形成螺纹。

接下来更深的钻进过程会在进口处上方，对丝锥螺纹侧面之间的材料形成径向塑性变形，直达到进口长度。在这个点上，将形成具有正确螺纹高度的完整螺纹。

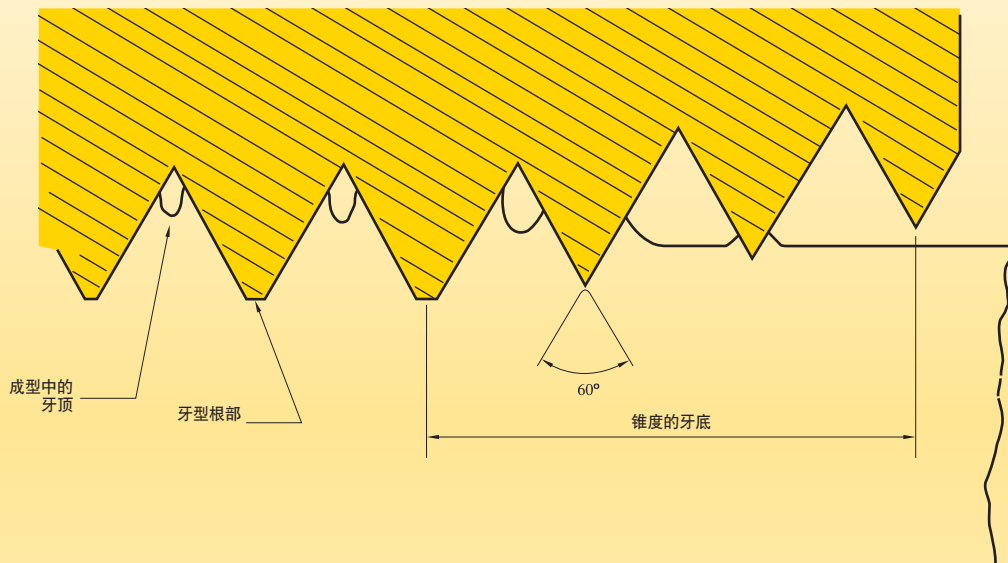

与切削丝锥相比，挤压丝锥具有多种优势。明显的优势在于挤压丝锥不会形成切屑。不会导致排屑问题。鸟巢状切屑的形成是在对长切屑材料进行盲孔攻丝加工中，切屑缠绕在螺旋槽丝锥的刀杆上而导致的。挤压丝锥可以避免这种问题。因为挤压丝锥可以避免这种问题，因此产品更加坚固，并且具有更好的抗断裂性。另外一个误区是，挤压丝锥加工出的螺纹更加坚固。尽管在成型过程中，螺纹的侧面得到硬化，但对螺纹大径几乎没有任何效果，而这个部位正是内螺纹出现剥离的位置。

挤压丝锥仅能用于延性材料的加工。与切削丝锥相比，挤压丝锥在加工过程增大了摩擦系数，因此需要更大的加工扭矩。在有些情况下，需要使用油基润滑液，这种情况可能并不适合需要水基冷却液的CNC加工中心。在这种情况下，需要增加润滑液浓度。

因为挤压丝锥会造成材料的位移，因此需要更大直径的预钻孔。在将切削丝锥更换为挤压丝锥的情况下，这一点尤为重要。如果采用切削丝锥的预加工孔，位移材料将过度充塞于丝锥的齿牙之间，并导致齿牙断裂。请参看挤压丝锥加工孔参数表。

涂层	属性和应用	防范措施
氮化钛 (TiN)	专利 TiN 涂层 (维氏硬度 2300) 具有显著改善的耐磨损性能和螺纹精加工性能, 在多种类型材料加工中, 特别是钢、铁, 和塑料材料加工中具有很高的攻丝速度性能。金色外观。	在例如铝之类的非铁材料应用中应谨慎使用, 因为可能产生刮擦磨损。
碳氮化钛 (TiCN)	与 TiN 涂层相比, 专利 TiCN 涂层 (维氏硬度 3000) 是一种硬度更高, 韧性更好, 更加耐磨损的涂层, 适用于一般切削温度条件下的加工。与 TiN 相似, TiCN 可用于多种材料的高速切削应用, 特别是钢和铁材料的加工。蓝灰色外观。	在例如铝之类的非铁材料应用中应谨慎使用, 因为可能产生刮擦磨损。在超高温条件下, TiAlN 是一种更好的选择。
氮化钛 + 碳化铬 (TiN + CrC/C)	专利涂层 (韦氏硬度为 2300) 产品, 将光滑的 TiN 涂层的耐磨性和碳化铬表层涂层的润滑性结合在一起。在不锈钢和包括铝和钛在内的非铁材料加工中非常高效。非常适合 300 系列不锈钢, 锻铝和铸铝材料的加工。黑色/灰色外观。	在铁基材料和非铁材料加工中都非常高效。
氮化钛铝 (TiAlN)	纳米 TiAlN 涂层 (韦氏硬度为 3300) 具有更好的耐磨性和螺纹精加工性能, 特别是在高温应用条件下有出色的表现。可用于 PH 不锈钢和类似于 INCONEL® 的镍基合金材料加工。紫罗兰色/灰色外观。	在非铁材料应用中应谨慎使用, 因为可能产生刮擦磨损。
氮化铬 (CrN)	CrN 是一种中等硬度 (维氏硬度为 1800) 的涂层, 耐磨性比 TiN, TiCN 和 TiAlN 要低。但是, 与这些涂层不一样的是, CrN 在一些非铁材料加工中不会出现刮擦磨损。用于黄铜、青铜、锌合金, 以及锰合金材料的加工。银色外观。	在铁基材料加工中效率低。
氮化硼	硬化表面确保在磨损性材料加工中有更长的磨损寿命。用于铝材料和非铁金属材料加工。	避免用于锥形管、陡螺旋, 小直径 (<#6), 以及密齿攻丝应用, 因为这将导致齿牙崩裂的可能。
氧化	在铁基材料加工中可提高防刮擦磨损的性能。用于钢材料的平稳切削。用于钢、不锈钢、铁材料加工。	在非铁材料, 例如铝材料的加工中有导致刮擦磨损的可能。
氮化和氧化处理	将氮化和氧化表面处理的优点结合在一起。用于钢、不锈钢, 以及镍合金材料的加工。	参看氮氧化表面处理的防范措施。

确定攻丝速度的因素:

- 攻丝材料
- 丝锥上的切削锥长度
- 全螺纹切削比例
- 孔长度 (螺纹深度)
- 螺距
- 切削液
- 机床
- 水平或垂直攻丝

与其它多种刀具产品一样, 在计算丝锥良好加工速度时, 并不能确定准确的数值。

在使用其它种类刀具时, 可以在任何位置对每转进给量进行设定, 并且可根据具体情况进行变动。但丝锥则不同, 丝锥的每转进给量必须保持为单个螺距距离。丝锥类型也会导致加工条件的变化。

举例而言, 在使用E型切削锥丝锥时, 在每个切削锥上的第一个齿牙切削出完整高度的螺纹; 而在使用锥形或初始丝锥时, 在形成完整高度的螺纹之前, 多个齿牙同时参与切削过程。

螺纹深度也会根据牙距而发生改变。牙距越大, 丝锥的每转进给量就越大, 去除的材料量就越多。

丝锥的进给方式, 以及驱动设备的类型也会对加工速度造成影响。如果丝锥采用机械进给方式, 并按照适当的进给率, 就可按照较高的速度进行加工; 如果采用手动进给, 并需要拉动机床上的某些工件时, 加工速度则较低。

可根据以下部分或全部因素调整加工速度:

- 在螺纹长度增加的情况下必须降低加工速度, 因为在较深螺纹孔中, 聚集的切屑会增加摩擦, 并影响润滑性能。
- 与B型切削锥丝锥相比, E型切削锥丝锥的加工速度应该更低。
- 在进行全高度螺纹攻丝加工中, 需要降低加工速度; 而在商业用 75% 高度螺纹加工中, 则可相对调高加工速度。
- 与相同直径的细牙丝锥相比, 较大直径的粗牙丝锥应当降低加工速度。
- 切削液的数量及质量会对加工速度的影响可达一倍。
- 包括管用丝锥在内的锥形螺纹丝锥的加工速度应为相同大径规格的直螺纹丝锥加工速度的 1/2-3/4。

■ RPM 计算公式

SFM = 每分钟表面英尺数

RPM = 每分钟转数

IPM = 每分钟英寸数

TPI = 每英寸螺纹牙数

S m/min = 每分钟表面米数

$\pi = 3.1416$

mm/min = 每分钟毫米

P = 牙距 (1/每英寸螺纹牙数)

英寸规格

$$\begin{aligned} \text{SFM} &= \frac{\text{RPM} \times \text{刀具直径}}{3.82} && \text{或} && 0.26 \times \text{RPM} \times \text{刀具直径} \\ \text{RPM} &= \frac{3.82 \times \text{SFM}}{\text{刀具直径}} \\ \text{IPM} &= \frac{\text{RPM}}{\text{TPI}^*} && \text{或} && *P \times \text{RPM} \end{aligned}$$

公制尺寸

$$\begin{aligned} \text{S m/min} &= \frac{\pi \times \text{刀具直径} \times \text{RPM}}{1000} \\ \text{RPM} &= \frac{\text{mm/min} \times 1000}{\pi \times \text{刀具直径}} \\ \text{mm/min} &= \text{mm P} \times \text{RPM} \end{aligned}$$

■ UNC/UNF 和 NPT/NPTF

丝锥规格	锥形管用 丝锥	每分钟表面英尺数 (SFM)																	
		5'	10'	15'	20'	25'	30'	40'	50'	60'	70'	80'	90'	100'	110'	120'	130'	140'	150'
		每分钟转数 (RPM)																	
0	—	318	637	955	1273	1592	1910	2546	3183	3820	4456	5093	5729	6366	7003	7639	8276	8913	9549
1	—	273	546	819	1046	1308	1570	2093	2617	3140	3663	4186	4710	5233	5756	6279	6805	7326	1849
2	—	212	424	637	888	1110	1333	1777	2221	2665	3109	3554	3999	4442	4886	5330	5774	6218	6662
3	—	191	382	573	772	964	1157	1543	1929	2315	2701	3086	3472	3858	4244	4629	5015	5401	5787
4	—	174	347	521	682	853	1023	1364	1705	2046	2387	2728	3069	3411	3751	4092	4434	4775	5115
5	—	147	294	441	611	764	917	1222	1528	1833	2139	2445	2750	3056	3361	3667	3973	4278	4584
6	—	136	273	409	553	691	829	1106	1382	1659	1935	2212	2488	2766	3042	3318	3595	3871	4148
8	—	119	239	358	466	583	699	932	1165	1398	1631	1864	2097	2330	2563	2796	3029	3262	3495
10	—	101	201	302	402	502	603	804	1005	1205	1406	1607	1808	2009	2210	2411	2612	2813	3014
12	—	87	174	260	354	442	531	707	884	1061	1238	1415	1592	1769	1945	2122	2300	2476	2653
1/4	—	76	153	229	306	382	458	611	764	917	1070	1222	1375	1528	1681	1833	1986	2139	2292
5/16	—	62	123	185	245	306	367	489	611	733	856	978	1100	1222	1345	1467	1589	1711	1833
3/8	—	50	101	151	204	255	305	407	509	611	713	815	917	1019	1120	1222	1324	1426	1528
7/16	1/8	43	87	130	175	219	262	349	437	524	611	698	786	873	960	1048	1135	1222	1310
1/2	—	38	76	115	153	191	229	305	382	458	535	611	688	764	840	917	993	1070	1146
9/16	1/4	34	68	102	137	172	206	274	342	410	478	547	616	683	752	820	888	952	1020
5/8	—	32	64	96	122	153	183	244	306	367	428	489	550	611	672	733	794	856	917
11/16	3/8	28	55	83	111	138	167	222	278	333	389	444	500	556	611	667	722	778	833
3/4	—	25	51	76	102	128	153	203	255	305	357	407	458	509	560	611	662	713	764
7/8	1/2	22	43	65	87	109	131	175	218	262	306	350	392	437	480	524	568	611	655
1	—	19	38	57	76	96	115	153	191	230	268	305	344	382	420	458	497	535	573
1-1/8	3/4	17	34	51	68	84	102	136	170	204	238	272	306	340	373	407	441	475	509
1-1/4	—	15	31	46	61	76	92	122	153	183	214	244	275	305	336	367	397	428	458
1-3/8	1	14	28	42	56	69	83	111	139	167	194	222	250	278	306	333	361	389	417
1-1/2	—	13	25	38	51	63	76	102	127	153	178	204	229	255	280	305	331	356	382
1-5/8	—	12	23	35	47	59	71	94	118	141	165	188	212	235	259	282	306	329	353
1-3/4	—	11	22	33	44	55	65	87	109	131	153	175	196	218	240	262	284	306	327
1-7/8	—	10	20	30	41	51	61	81	102	122	143	163	183	204	224	244	265	285	306
2	—	9	19	29	38	48	57	76	96	115	134	153	172	191	210	229	248	267	287



■ 公制

公制丝锥	Vc = 每分钟米数 (m/min)																	
	1,5	3	4,5	6	7,5	10	12	15	18	21	24	27	30	33	36	39	42	45
	每分钟转数 (RPM)																	
M1	490	979	1469	1959	2449	2938	3918	4897	5877	6856	7836	8815	9795	10774	11754	12733	13713	14692
M2	242	484	725	967	1209	1451	1934	2418	2901	3385	3868	4352	4835	5319	5803	6286	6770	7253
M3	162	324	486	647	809	971	1295	1619	1942	2266	2590	2914	3237	3561	3885	4208	4532	4856
M3.5	138	277	415	554	692	830	1107	1384	1661	1938	2214	2491	2768	3045	3322	3599	3875	4152
M4	122	243	365	487	608	730	973	1217	1460	1703	1946	2190	2433	2676	2920	3163	3406	3650
M5	97	194	291	388	485	582	776	970	1163	1357	1551	1745	1939	2133	2327	2521	2715	2905
M6	81	162	243	324	405	486	647	809	971	1133	1295	1457	1619	1781	1942	2104	2266	2428
M7	69	138	208	277	346	415	554	692	830	969	1107	1246	1384	1522	1661	1799	1938	2076
M8	61	121	182	243	303	364	485	606	728	849	970	1091	1213	1334	1455	1577	1698	1819
M10	48	97	145	194	242	291	388	485	582	679	776	873	970	1067	1163	1260	1357	1454
M12	40	81	121	162	202	243	324	405	486	567	647	728	809	890	971	1052	1133	1214
M14	35	69	104	139	173	208	277	347	416	485	555	624	693	763	832	901	971	1040
M16	30	61	91	121	152	182	243	303	364	424	485	546	606	667	728	788	849	910
M18	27	54	81	108	135	162	216	269	323	377	431	485	539	593	647	700	754	808
M20	24	49	73	97	121	146	194	243	291	340	388	437	485	534	582	631	680	728
M22	22	44	66	88	110	132	176	221	265	309	353	397	441	485	529	573	618	662
M24	20	40	61	81	101	121	162	202	243	283	323	364	404	445	485	526	566	606
M27	18	36	54	72	90	108	144	180	216	252	287	323	359	395	431	467	503	539
M30	16	32	49	65	81	97	129	162	194	226	259	291	323	356	388	420	453	485

攻丝故障部分解决方案

应用	现象	常见原因	排除方法
普通应用	环规超限	丝锥规格与环规不配套	根据环规选择丝锥规格
	螺纹尺寸过大	工件对准, 主轴进给	校正
	顶部尺寸过大	跳动或工件对准	校正
	通规部分不过	刀具磨损, 丝锥导向能力减小	更换丝锥, 采用同步刀柄
	过切螺纹	进给错误, 轴向力过大	编程, 同步刀柄
	崩刃	切削力过大, 丝锥磨损	丝锥槽型, 更换丝锥
	破损	切屑阻塞排屑槽	丝锥槽型, 攻丝深度
	—	刀具磨损, 高扭矩	更换新丝锥
	寿命短, 速度低	过度磨损	SC 或 HSS-E-PM HP 丝锥
钢	盲孔鸟巢切屑	长型, 延性切屑。	T630 KP6505 (氧化处理), 断续进给
	崩刃	材料硬度大	T600, T602 KSP21 (TiN)
	盲孔内破损	孔深 >2D, 切屑卡滞	T604 KHS26 (TiN/MoS ₂)
不锈钢	螺纹尺寸过大, 寿命短	磨擦	T620, T630 KM6515 (TiN-CrC/C)
	寿命短	工件硬化型芯孔	更换钻头
铸铁	过度磨损	磨损	T640 KP6525 (TiCN)
铸铝	过度磨损	高硅	T640 KP6525 (TiCN)
锻铝	螺纹尺寸过大	磨损	T672, T682, T686 KSMN34 (TiN-CrC/C)
镍基, 钴基合金	寿命短	切削温度高	T690, T692, T694 KSP27 (AlCrTiN)
钛	寿命短	切削温度高	T660, T662 KSSM24 (TiN-CrC/C)

螺纹铣刀

	震动标记	主齿顶磨损	崩刃	锥形螺纹	进刀标记
切削速度	检查	减小	—	—	—
每齿进给量	检查	增大	减小	—	—
工件夹持	改善	改善	改善	—	改善
刀具稳定性。	改善	改善	改善	—	改善
悬臂	缩短	缩短	—	—	缩短
螺旋角	增大	减小	—	—	—
径向跳动	检查	检查	—	—	—
涂层	—	改善	改善	—	—
铣削加工	—	顺铣	顺铣	顺铣	—
线性进给/进刀坡度	检查	检查	—	—	改善
冷却剂压力	—	检查 (>20 bar, 290 psi)	检查 (>20 bar, 290 psi)	—	—

钻头尺寸	十进制 (英寸)	钻头尺寸	十进制 (英寸)	钻头尺寸	十进制 (英寸)	钻头尺寸	十进制 (英寸)	钻头尺寸	十进制 (英寸)	钻头尺寸	十进制 (英寸)
0,30mm	.0118	54	.0550	3,10mm	.1220	5,50mm	.2165	8,50mm	.3346	9/16	.5625
0,32mm	.0126	1,40mm	.0551	1/18	.1250	7/32	.2188	8,60mm	.3386	14,50mm	.5709
80	.0135	1,45mm	.0571	3,20mm	.1260	5,60mm	.2205	R	.3390	37/64	.5781
0,35mm	.0138	1,50mm	.0591	30	.1285	2	.2210	8,70mm	.3425	14,75mm	.5807
79	.0145	53	.0595	3,30mm	.1299	5,70mm	.2244	11/32	.3438	15,00mm	.5906
0,38mm	.0150	1,55mm	.0610	3,40mm	.1339	1	.2280	8,80mm	.3465	19/32	.5938
1/64	.0156	1/16	.0625	29	.1360	5,80mm	.2283	S	.3480	15,25mm	.6004
0,40mm	.0157	1,60mm	.0630	3,50mm	.1378	5,90mm	.2323	8,90mm	.3504	39/64	.6094
78	.0160	52	.0635	28	.1405	A	.2340	9,00mm	.3543	15,50mm	.6102
0,42mm	.0165	1,65mm	.0650	9/64	.1406	15/64	.2344	T	.3580	15,75mm	.6201
0,45mm	.0177	1,70mm	.0669	3,60mm	.1417	6,00mm	.2362	9,10mm	.3583	5/8	.6250
77	.0180	51	.0670	27	.1440	B	.2380	23/64	.3594	16,00mm	.6299
0,48mm	.0189	1,75mm	.0689	3,70mm	.1457	6,10mm	.2402	9,20mm	.3622	16,25mm	.6398
0,50mm	.0197	50	.0700	26	.1470	C	.2420	9,30mm	.3661	41/64	.6406
76	.0200	1,80mm	.0709	25	.1495	6,20mm	.2441	U	.3680	16,50mm	.6496
75	.0210	1,85mm	.0728	3,80mm	.1496	D	.2460	9,40mm	.3701	21/32	.6562
0,55mm	.0217	49	.0730	24	.1520	6,30mm	.2480	9,50mm	.3740	16,75mm	.6594
74	.0225	1,90mm	.0748	3,90mm	.1535	1/4, E	.2500	3/8	.3750	17,00mm	.6693
0,60mm	.0236	48	.0760	23	.1540	6,40mm	.2520	V	.3770	43/64	.6719
73	.0240	1,95mm	.0768	5/32	.1562	6,50mm	.2559	9,60mm	.3780	17,25mm	.6791
0,62mm	.0244	5/64	.0781	22	.1570	F	.2570	9,70mm	.3819	11/16	.6875
72	.0250	47	.0785	4,00mm	.1575	6,60mm	.2598	9,80mm	.3858	17,50mm	.6890
0,65mm	.0256	2,00mm	.0787	21	.1590	G	.2610	W	.3860	45/64	.7031
71	.0260	2,05mm	.0807	20	.1610	6,70mm	.2638	9,90mm	.3898	18,00mm	.7087
0,70mm	.0276	46	.0810	4,10mm	.1614	17/64	.2656	25/64	.3906	23/32	.7188
70	.0280	45	.0820	4,20mm	.1654	H	.2660	10,00mm	.3937	18,50mm	.7283
69	.0292	2,10mm	.0827	19	.1660	6,80mm	.2677	X	.3970	47/64	.7344
0,75mm	.0295	2,15mm	.0846	4,30mm	.1693	6,90mm	.2717	10,20mm	.4016	19,00mm	.7480
68	.0310	44	.0860	18	.1695	I	.2720	Y	.4040	3/4	.7500
1/32	.0312	2,20mm	.0866	11/64	.1719	7,00mm	.2756	13/32	.4062	49/64	.7656
0,80mm	.0315	2,25mm	.0886	17	.1730	J	.2770	Z	.4130	19,50mm	.7677
67	.0320	43	.0890	4,40mm	.1732	7,10mm	.2795	10,50mm	.4134	25/32	.7812
66	.0330	2,30mm	.0906	16	.1770	K	.2810	27/64	.4219	20,00mm	.7874
0,85mm	.0335	2,35mm	.0925	4,50mm	.1772	9/32	.2812	10,80mm	.4252	51/64	.7969
65	.0350	42	.0935	15	.1800	7,20mm	.2835	11,00mm	.4331	20,50mm	.8071
0,90mm	.0354	3/32	.0938	4,60mm	.1811	7,30mm	.2874	7/16	.4375	13/16	.8125
64	.0360	2,40mm	.0945	14	.1820	L	.2900	11,20mm	.4409	21,00mm	.8268
63	.0370	41	.0960	4,70mm, 13	.1850	7,40mm	.2913	11,50mm	.4528	53/64	.8281
0,95mm	.0374	2,45mm	.0965	3/16	.1875	M	.2950	29/64	.4531	27/32	.8438
62	.0380	40	.0980	4,80mm, 12	.1890	7,50mm	.2953	11,80mm	.4646	21,50mm	.8465
61	.0390	2,50mm	.0984	11	.1910	19/64	.2969	15/32	.4688	55/64	.8594
1,00mm	.0394	39	.0995	4,90mm	.1929	7,60mm	.2992	12,00mm	.4724	22,00mm	.8661
60	.0400	38	.1015	10	.1935	N	.3020	12,20mm	.4803	7/8	.8750
59	.0410	2,60mm	.1024	9	.1960	7,70mm	.3031	31/64	.4844	22,50mm	.8858
1,05mm	.0413	37	.1040	5,00mm	.1969	7,80mm	.3071	12,50mm	.4921	57/64	.8906
58	.0420	2,70mm	.1063	8	.1990	7,90mm	.3110	1/2	.5000	23,00mm	.9055
57	.0430	36	.1065	5,10mm	.2008	5/16	.3125	12,80mm	.5039	29/32	.9062
1,10mm	.0433	7/64	.1094	7	.2010	8,00mm	.3150	13,00mm	.5118	59/64	.9219
1,15mm	.0453	35	.1100	13/64	.2031	O	.3160	33/64	.5156	23,50mm	.9252
56	.0465	2,80mm	.1102	6	.2040	8,10mm	.3189	13,20mm	.5197	15/16	.9375
3/64	.0469	34	.1110	5,20mm	.2047	8,20mm	.3228	17/32	.5312	24,00mm	.9449
1,20mm	.0472	33	.1130	5	.2055	P	.3230	13,50mm	.5315	61/64	.9531
1,25mm	.0492	2,90mm	.1142	5,30mm	.2087	8,30mm	.3268	13,80mm	.5433	24,50mm	.9646
1,30mm	.0512	32	.1160	4	.2090	21/64	.3281	35/64	.5469	31/32	.9688
55	.0520	3,00mm	.1181	5,40mm	.2126	8,40mm	.3307	14,00mm	.5512	25,00mm	.9843
1,35mm	.0531	31	.1200	3	.2130	Q	.3320	14,25mm	.5610	63/64	.9844
—	—	—	—	—	—	—	—	—	—	1"	1.0000

■ 公制
 ■ 分数制
 ■ 标线制
 ■ 字母制

定制丝锥产品表格

使用这份客户订单表订购产品，可以根据具体要求对现有产品数据进行修改。如果这些类别的产品不能满足客户的要求，请与当地的肯纳金属经销商联系。

我们的经销商和技术团队有着非常丰富的经验，可为客户提供的产品解决方案，值得客户的信赖。

1. 首先填写与客户产品规格最接近的标准型产品信息:

产品目录编号

材质/涂层

2. 所需丝锥类型:

整体硬质合金 高性能 HSS 通用加工 刃倾角
 方向 挤压 螺旋槽
 _____ (以及类型) _____ 其它

3. 切削方向 (圈选一个):

左手

右手

4. 材料概览:

ANSI DIN JIS 其它

5. 需要尺寸:

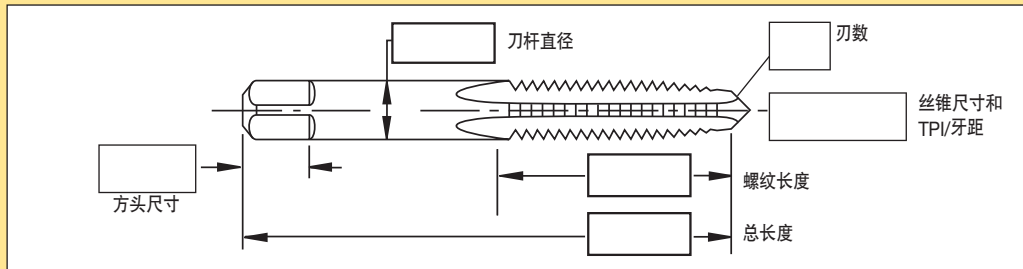

6. 选择一个:

通孔: 孔直径 _____ 孔深 _____
盲孔: 孔直径 _____ 孔深 _____

7. 切削锥:

锥形: 7-10 个齿牙 切削锥: 3-5 个螺牙 半底: 2-3 个螺牙 底部: 1-2 个螺牙



8. 公差等级:

H 限度

公制 D 限度

中径限度

9. 工件材料:

10. 硬度:

11. 需要丝锥数量:

12. 价格

联系当地的肯纳金属授权经销商。

13. 其它要求:

客户公司名称	日期
地址	电话号码
城市, 州, 邮编	传真机号码
客户联系人	客户电子邮箱
销售人员	

■ 螺纹铣削应用表

测试类型螺纹数据	日期:
客户数据	
公司:	部门:
街道:	职位:
邮政编码:	电话:
城市:	传真:
国家:	电子邮箱:
刀具数据	
使用肯纳金属刀具:	刀具寿命:
竞争性刀具:	
工件数据	
螺纹尺寸:	工件名称:
公差等级:	图片、示意图
螺纹深度: mm	
螺纹类型: <input type="checkbox"/> 通孔 <input type="checkbox"/> 盲孔	
钻孔直径 Ø: mm	
钻孔深度: mm	
钻孔类型: <input type="checkbox"/> 已钻孔 <input type="checkbox"/> 无钻孔	
材料:	
硬度:	
机床数据	
制造商:	描述:
CNC 机床类型: <input type="checkbox"/> 车床 <input type="checkbox"/> 铣床	工作方向: <input type="checkbox"/> 水平 <input type="checkbox"/> 垂直
控制类型: <input type="checkbox"/> DIN <input type="checkbox"/> Heidenhain	冷却方式: <input type="checkbox"/> 乳状切削液 <input type="checkbox"/> 微量润滑 <input type="checkbox"/> 压缩空气 <input type="checkbox"/> 干式
冷却液供应类型: <input type="checkbox"/> 内冷 <input type="checkbox"/> 外冷	冷却液压力: Bar
最大转数: <input type="checkbox"/> 1/min	主轴功率: kW
夹持装置: <input type="checkbox"/> Weldon® <input type="checkbox"/> 筒夹 <input type="checkbox"/> 热套配合 <input type="checkbox"/> 液压膨胀夹头	
切削条件	
切削速度 Vc m/min	转数: 1/min
进给率 fz mm/tooth	编程进给率: mm/min
铣削方向: <input type="checkbox"/> 顺铣 <input type="checkbox"/> 逆铣	进给类型: <input type="checkbox"/> 相切点进给量 <input type="checkbox"/> 中心点进给量
螺纹深度上的分配切削长度: <input type="checkbox"/> 是 <input type="checkbox"/> 否	轮廓上的分配切削长度: <input type="checkbox"/> 根据轮廓的深度 <input type="checkbox"/> 根据螺纹深度
切削次数:	切削次数:

了解将要进行攻丝加工材料的硬度，对于选择适用的丝锥产品非常需要。

10 mm/min 球体 3000 kg	120° 圆锥体 150 kg	1/16" 球体 100 kg	C 型	1000磅 每平方英寸	10 mm/min 球体 3000 kg	120° 圆锥体 150 kg	1/16" 球体 100 kg	C 型	1000磅 每平方英寸
布氏硬度	洛氏硬度 C	洛氏硬度 B	肖氏 硬度	抗拉 强度	布氏硬度	洛氏硬度 C	洛氏硬度 B	肖氏 硬度	抗拉 强度
800	72	-	100	-	276	30	105	42	136
780	71	-	99	-	269	29	104	41	132
760	70	-	98	-	261	28	103	40	129
745	68	-	97	367	258	27	102	39	127
725	67	-	96	357	255	26	102	39	125
712	66	-	95	350	249	25	101	38	123
682	65	-	93	337	245	24	100	37	119
668	64	-	91	326	240	23	99	36	117
652	63	-	89	318	237	23	99	35	115
626	62	-	87	306	229	22	98	34	113
614	61	-	85	299	224	21	97	33	110
601	60	-	83	292	217	20	96	33	107
590	59	-	81	290	211	19	95	32	104
576	57	-	79	281	206	18	94	32	102
552	56	-	76	270	203	17	94	31	100
545	55	-	75	268	200	16	93	31	98
529	54	-	74	259	196	15	92	30	96
514	53	120	72	254	191	14	92	30	94
502	52	119	70	247	187	13	91	29	92
495	51	119	69	244	185	12	91	29	91
477	49	118	67	233	183	11	90	28	90
461	48	117	66	227	180	10	89	28	89
451	47	117	65	223	175	9	88	27	86
444	46	116	64	219	170	7	87	27	84
427	46	115	62	209	167	6	87	27	82
415	44	115	60	204	165	5	86	26	81
401	43	114	58	196	163	4	85	26	80
388	42	114	57	191	160	3	84	25	78
375	41	113	55	184	156	2	83	25	76
370	40	112	54	182	154	1	82	25	75
362	39	111	53	179	152	-	82	24	74
351	38	111	51	173	150	-	81	24	74
346	37	110	50	170	147	-	80	24	72
341	37	110	49	168	145	-	79	23	71
331	36	109	47	163	143	-	79	23	70
323	35	109	46	158	141	-	78	23	69
311	34	108	46	153	140	-	77	22	69
301	33	107	45	148	135	-	75	22	67
293	32	106	44	144	130	-	72	22	65
285	31	105	43	140	-	-	-	-	-

攻丝